



Montana Department of
ENVIRONMENTAL QUALITY

Judy Martz, Governor

P.O. Box 200901 • Helena, MT 59620-0901 • (406) 444-2544 • Website: www.deq.state.mt.us

November 2002

Dear Reader:

Enclosed for your review and comment is the Draft Environmental Impact Statement (EIS) for the proposed Roundup Power Project.

Bull Mountain Development Company, LLC, is seeking an air quality permit from the Montana Department of Environmental Quality (DEQ) for its proposed coal-fired electric generation plant near Roundup, Montana. The Draft EIS analyzes the potential impacts of the proposal, as well as potential impacts of alternatives: 1) No Action; 2) Landfill Alternative; and 3) 230kV Transmission System Alternative. The Draft EIS addresses issues and concerns raised during a scoping meeting in Roundup on April 4, 2002, and written comments received between March 20 and April 19, 2002. Application materials are available for review in the DEQ offices in Helena and Billings.

DEQ has selected the Proposed Action as modified by the Landfill Alternative as its preliminary preferred alternative. **This is not a final decision.** The preferred alternative could change in response to public comment on the Draft EIS, new information, or analysis that might be needed in preparing the Final EIS.

Public comments concerning the adequacy and accuracy of the Draft EIS will be accepted until December 18, 2002. Written comments may be sent, postmarked no later than December 18, 2002, to the Montana Department of Environmental Quality, P.O. Box 200901, Helena, MT 59620-0901, Attn: Greg Hallsten. Comments may be sent via e-mail to ghallsten@state.mt.us.

A public hearing will be held to receive oral or written comments in Roundup on December 5, 2002, at 7:00 p.m. in the Roundup Community Center.

Since the Final EIS might only contain public comments and responses, and changes to the Draft EIS, please keep this Draft EIS for future reference.

Sincerely,

Jan P. Sensibaugh
Director

PLAINTIFFS'
EXHIBIT

P232

Roundup Power Project

Draft Environmental Impact Statement



EXECUTIVE SUMMARY

Introduction

The Roundup Power Project (Project) is a proposed coal-fired electric Generation Plant located on private property about 35 miles north of Billings and 13 miles south-southeast of Roundup, Montana. A map of the proposed Project Area is shown in Figure ES-1. The Bull Mountain Development Company (proponent) submitted an application for an air quality permit to the Montana Department of Environmental Quality (DEQ) on January 14, 2002. The application, which had to meet the requirements of the Montana Clean Air Act (75-2-201 et seq., MCA and ARM 17.8.701 et seq.), was found to be adequate on July 22, 2002. This started a mandatory 180-day time frame for the environmental review under the Montana Environmental Policy Act (MEPA). The DEQ is the lead agency and is responsible for completing the Environmental Impact Statement (EIS) before issuing the Final Air Quality Permit (75-1-201, MCA).

The Project is designed to be a mine-mouth generating facility using coal from the existing Bull Mountains Mine (Mine) located adjacent to the Project. To meet its coal supply needs, the Project proponent has entered into contractual agreements with the Mine to purchase approximately 2.7 million tons of coal per year. Coal would be delivered from the Mine to the Generation Plant by a 4,000-foot-conveyer system.

A new 161 kilovolt (kV) transmission system, approximately 28.2 miles long, would be built from the Generation Plant to NorthWestern Energy's Broadview Substation, interconnecting with the northwest transmission network. Power generated by this facility would be sold to all classes of electricity consumers (residential, municipal, cooperative, commercial, and industrial customers). The route for the transmission lines would be within or immediately adjacent to the Mine's rail corridor.

Two electric generating units, each with a pulverized coal-fired boiler and a steam turbine generator, are proposed. Each unit would be designed to generate a nominal 390 megawatts (MW) gross (350MW net) electrical capacity year-round on a 24-hour-per-day basis, except during planned maintenance periods and occasional repair outages when one unit would normally remain operating. Four to six groundwater wells, approximately 8,500 feet deep, are proposed as the Project's water supply.

Air pollution emissions, wastewater discharges, solid waste disposal, and other significant aspects of the Project would comply with applicable permits and environmental requirements.

Purpose and Need for the Action

The primary needs for the Project are to serve population growth, load growth, and the need for new base load electrical generation. That population and electrical demand growth, together with the retirement of older, less efficient electrical generating units, requires the continued development of new and cleaner generation sources. The Project would fill a portion of this need.

The Project would be built specifically to burn coal. The mine-mouth fuel source of the Project would provide stable pricing and reliability for base load power that is needed by the utilities to reliably serve industrial, commercial, and residential customers.

The Project would also increase the opportunity for competition in the regional energy market by increasing the total amount of electricity that could be transmitted reliably within the grid. Competition in the power marketplace is viewed as the best means in a market economy to keep power pricing in line with customer demand and need and competitive pricing of industrial production and output. Some of the electricity could be consumed by industrial, commercial, and residential customers in Montana. NorthWestern Energy currently is evaluating the interconnection of the Project with their transmission system at the Broadview Substation.

Issues Identified During Scoping

Before preparation of this Draft EIS, DEQ invited the participation of affected federal, state, and local government agencies, Indian tribes, the Project sponsors, and interested persons and groups to discuss issues, concerns, and opportunities, and to help identify the scope of the EIS. During this scoping process DEQ also identified possible alternatives to the Proposed Action.

On April 4, 2002, a public scoping meeting was held by the DEQ in the City of Roundup to identify issues and concerns. Comments were also accepted by mail. In addition, the Project proponent has sought public participation by making three presentations to the Legislature's Transition Advisory Committee, by participating in the Governor's Conference on Economic Development on March 7, 2002, in Billings, and by making a presentation to the executive board of the Big Sky Economic Development Authority in Billings.

The issues of concern raised during the public and agency scoping process include:

- Socioeconomic Effects - impacts on schools, law enforcement, and other public services due to in-migration of Generation Plant workers, changes in social setting and attitudes due to in-migration of Generation Plant workers, impacts associated with increased traffic, and infrastructure impacts.
- Air Quality - impacts due to pollution emissions during Generation Plant operation, global climate impacts due to greenhouse gas emissions during Generation Plant operation, and cumulative visibility impacts.
- Water Resources - impacts on surface water or groundwater quality due to solid waste disposal and other Generation Plant activities, and impacts on groundwater levels and supplies due to withdrawals during Generation Plant operation.
- Noise - disturbance of nearby residents by noise from Generation Plant construction and operation.
- Infrastructure - adequacy of existing transmission system to carry the Generation Plant output.
- DEQ Regulatory Actions and Response - evaluation/regulation for combined impacts of the Generation Plant and other industrial developments in the region, monitoring of the

Generation Plant construction process, including depth of groundwater wells, and response to Generation Plant emissions exceedances of permitted levels, accidents during Generation Plant operations and issues involving the proposed landfill.

Alternatives Considered and Eliminated

The Project proponent identified numerous alternatives to the Project, including:

- Fuel Sources
- Water Supplies
- Cooling Systems
- Combustion Systems
- Solid Waste Systems
- Wastewater Discharge Systems
- Emission Control Systems
- Generation Sites

The alternatives described in this section were eliminated from further consideration because they did not meet the stated purpose and need for the Proposed Action or were found to be economically unreasonable. A summary comparison of the alternatives considered and eliminated is provided in Table ES-1.

Alternatives Analyzed in Detail

There are two alternatives to components of the Proposed Action:

- Waste disposal from the Generation Plant
- Transmission of electricity into the interconnected grid in the western United States

In addition, a No-Action Alternative was analyzed in detail.

Landfill Alternative

Over the life of the Project, construction and operation of additional landfill cells on the Generation Plant site is proposed as an alternative to moving most of the solid waste to the Mine for disposal. The landfill would be a state-of-the-art facility designed with two cells, providing 60 acres for solid waste storage. The disposal area would be lined for the protection of groundwater and provided with a leachate collection system not to exceed 10 acres to remove leachate and storm water that collects on top of the lining.

230kV Transmission System Alternative

Each generating unit would be designed to generate nominally 390MW gross (350MW net) electrical capacity year round on a 24-hour per day basis. As an alternative to the three circuits of 161kV transmission lines from the Generation Plant to the Broadview Substation, two single-circuit 230kV lines on wood pole H-frame structures in the same corridor as the Proposed Action

would be constructed. This would require a different transformer and associated equipment to support connection to a higher voltage transmission line. Equipment and construction would be similar to the 161kV Transmission System. Constructing the 230kV Transmission System Alternative would need a certificate under the Montana Major Facility Siting Act.

NorthWestern Energy's Broadview Substation is connected to the transmission grid in the northwest and coordinated by the Western Electricity Coordinating Council (WECC). Improvements are planned for the system to allow approximately 500MW to flow west towards Bonneville Power Administration's (BPA) Garrison Substation and approximately 200MW to flow south to PacifiCorp's Yellowtail Substation. Studies performed by these transmission providers have identified upgrades that are proposed and underway to support this flow.

No-Action Alternative

Under the No-Action alternative, the Generation Plant and the 161kV Transmission System to the Broadview Substation would not be constructed. The State of Montana would not issue the Final Air Permit for the Project. The purpose and need for the Project would not be met under the no-action alternative.

Preferred Alternative

The DEQ Preferred Alternative is the Proposed Action, with the addition of the Landfill Alternative for long-term solid waste disposal instead of long-term disposal in the mine. In this alternative, solid waste would be stored in landfill cells adjacent to the Generation Plant site for the life of the Project.

The alternative of disposing waste in the off-site landfill is preferred over the Proposed Action of long-term disposal of waste in the adjacent Mine, because it would result in the least impacts to environmental resources. The uncertainties associated with in-mine storage of waste make the Proposed Action a higher risk for causing impacts and possible contamination to soils, water bearing geological zones, and groundwater resources. In comparison, the use of lined and monitored landfill cells would minimize the risk of these impacts in the future. More information is needed to fully understand impacts from in-mine storage. Therefore, the Landfill Alternative is preferred.

With the construction and operation of the Proposed Action or the two alternatives (i.e., Landfill and 230kV Transmission), all resource areas, with the exception of fisheries, would experience some adverse environmental impacts (refer to Table E-2). Impacts that would result to vegetation and wildlife would include the loss of approximately 208 acres of grass/shrubland habitat for the Proposed Action or the action alternatives. However, this habitat is common and widespread in this portion of Montana, so impacts would be low. No federally listed or state sensitive species are known to exist in the Project study areas.

Air quality impacts was not a factor in selecting the Preferred Alternative, as impacts would not be measurably different under the Proposed Action or with selection of either of the action alternatives. Air resources were identified as having the highest Project-related impacts with most impacts ranging from low to moderate. A high impact to three Class 1 Areas (i.e., Yellowstone National Park, North Absaroka Wilderness, and Northern Cheyenne Reservation)

was identified from Project operations impairing visibility in these areas during specific periods of time each year.

Finally, the socioeconomic benefits of preferring the Proposed Action and the Landfill Alternative (i.e., the Preferred Alternative), as well as the benefits of adding the base load generation at this location and using the proposed fuel source, would outweigh the potential environmental consequences of constructing and operating the Project as the Preferred Alternative.

DEQ's preference for this alternative could change in response to public comments on the Draft EIS, new information, or analysis completed as part of the Final EIS.

Affected Environment

The Project would be located approximately 35 miles north of Billings and 13 miles south-southeast of the City of Roundup. The affected environment considered for the Generation Plant Study Area encompassed all of the land in Section 15, Township 6 North, Range 26 East in Musselshell County, Montana. Approximately 208 acres would be devoted to the Generation Plant. The Landfill Alternative would occupy an additional 70 acres of land adjacent to the Generation Plant. The proposed Transmission System and 230kV Alternative would be 28.2 miles in length, crossing Musselshell and Yellowstone Counties from the Generation Plant to Broadview Substation to the west.

The air quality in the Project study area is well within the applicable ambient air quality standards for all criteria pollutants. The Generation Plant would be located along the crest of the drainage divide between the Musselshell and Yellowstone rivers. There are no surface water bodies within the Generation Plant Study Area. There are two main aquifers: the shallow sandstone aquifers and the Madison aquifer, which is the proposed water source for the Project.

From on-site soils and vegetation surveys, it has been determined that there are no identified wetland resources within the Generation Plant Study Area. No federal or state-listed plant or wildlife species of concern are known to occur within the vicinity of the Project. The Bull Mountains surrounding the Project support a good diversity of wildlife. Many of these species, particularly non-game species, could occur at least seasonally on or adjacent to the proposed Project site.

A total of 65 cultural resources have been identified within the area of potential effect for the Project. Overall, the Project site contains visual resources such as Signal Mountain and The Bull Mountains. Foothills, ephemeral drainages, riparian vegetation, annual grasslands, and large expanses of ponderosa pine influence the natural visual setting. Human built features include: U.S. Highway 87, dispersed rural residential housing and agricultural fields along with grazing areas. No BLM or U.S. Forest Service (FS) lands occur within or near the Project site.

Environmental Consequences

Where potential impacts to a resource were identified, an evaluation was conducted to determine if one or more actions would be effective in avoiding or reducing (e.g. intensity and/or duration) the potential impact.

Proposed Action

The Project was assessed for compliance with MAAQS, NAAQS, and PSD increment levels as part of the air resources analysis. The area of impact included surrounding Class I areas (Yellowstone National Park, UL Bend Wilderness Area, North Absaroka Wilderness, and Northern Cheyenne Indian Reservation). The Project, by itself, was above the PSD modeling significance levels.

The proposed Generation Plant would directly impact approximately 208 acres of mostly grass/shrubland habitat with some ponderosa pine. Due to the widespread, common nature of this habitat, and because no federally-listed threatened and endangered species are known to occur in these areas, the loss to wildlife habitat, cattle grazing and agricultural practices would result in a low impact to these resources.

Impacts to ground water from in-mine storage of waste is unknown. More studies would be required to assess impacts. Zero discharge would cause low impacts on ground water resources from wastewater ponds and a solid waste landfill.

Soil erosion impacts would be low due to control of runoff from the Generation Plant.

Archaeological sites within three miles of the Generation Plant site would be impacted, of which eight are considered visually sensitive. The Generation Plant chimneys would visually impact residents and travelers.

Full economic benefits realized from implementation of the Proposed Action include tax benefits to Musselshell County and the State of Montana. Jobs would also be a benefit during construction and during the life of the Project.

Portions of a 28.2-mile long and 300-foot wide right-of-way would result in ground disturbance caused by transmission structures and access roads associated with the Project. The transmission right-of-way would remain available for wildlife habitat, cattle grazing and agricultural practices. Due to the widespread, common nature of this habitat, and because no federally-listed threatened and endangered species are known to occur in these areas, the loss to wildlife habitat, cattle grazing and agricultural practices would result in a low impact to these resources.

If cultural or paleontological resource are discovered during Project construction and cannot be avoided, recovery of these resources would ensure no irreversible and irretrievable loss to cultural resources. Visual impacts would occur at road crossings and from scattered residences along the transmission line corridor.

The Project operations would result in the consumption of approximately 8,000 tons of coal per day from the adjacent Mine, which would be irreversibly replaced by the generation of electricity. The loss of these coal reserves would be offset by the benefit of electricity generation by the Project.

Landfill Alternative

Approximately 70 additional acres would be disturbed to develop the waste disposal landfill and associated ditches and access road. Impacts would be similar to Proposed Action with minor soil erosion caused by the transport of waste from the Generating Plant to the expanded landfill site.

The Landfill Alternative would have no impacts on T&E species. The expansion of the landfill would be more noticeable than the Proposed Action, but would result in only low visual resource impacts. As with the Proposed Action, socioeconomic benefits would result from construction jobs, taxes for government agencies and social services, and long-term jobs from operation and maintenance of the facility.

230kV Transmission System Alternative

The 230kV alternative would require fewer circuits and larger conductors, taller poles but wider spans between poles, and different hardware than a lower voltage system to transport the Project's 750MW. During construction, existing roads would be used where feasible but some new roads and upgrades to existing roads would likely be needed. Ground disturbance on the right-of-way would result in permanent loss of acreage for the pole footings and any new access roads. Temporary disturbance at work areas could be returned to pre-project use following construction. No impacts would result to T&E species.

As with the Proposed Action, socioeconomic benefits would result from construction jobs, taxes for government agencies and social services, and improved transmission infrastructure.

Visual impacts would occur at road crossings and from scattered residences along the transmission line corridor.

Recommended Mitigation

Mitigation measures cannot be required by DEQ without a request from the Project proponent that they be placed in a permit (75-1-201(5)(b), MCA). The Project proponent may request that any or all of the mitigation measures that pertain to expected impacts from their proposed activities be placed in the permits. In those instances when the proponent chooses not to include a mitigation measure in a state permit, the Project proponent may decide to perform the proposed mitigation voluntarily.

Mitigation measures designed to avoid, reduce, or eliminate potential impacts were developed. They would generally consist of reducing ground disturbance effects, minimizing road crossing impacts to surface waters, measures to reduce the risk of groundwater impacts from waste disposal, minimize habitat loss, reclaim disturbed lands, reduce the impacts of soil erosion, span or avoid sensitive features, reduce visual contrast, minimize health and safety risks, minimize noise impacts, and reduce land use impacts.

Cumulative Impacts

Cumulative impacts result from the incremental impact of the Proposed Action when added to other past and present actions and future actions under state review.

Residential and Commercial Development

Currently residential and commercial developments are few in the Project study area and surrounding county. Eight rural residences are located within a mile of the Project. The City of Roundup, located approximately 13 miles to the north, is the closest urban development.

According to county records, no new residential developments are planned for the Project study area. However, given the amount of recent residential development, and the amount of land in the Project study area that is subdivided, it is reasonable to assume that a small level of development would occur in the future.

The nearest commercial establishment is the Brandin' Iron Saloon, which is located along U.S. Route 87, approximately two miles north-northwest of the Project study area. A convenience store and a log furniture store are proposed along U.S. Route 87, approximately two miles northwest of the Project study area. Other plans for the area include a recreational vehicle park and golf course.

Industrial Development

The PM Mine, an underground coal mining operation, was located partially in Section 14, east of the Project study area. The PM Mine ceased operation in the 1990s, but the Bull Mountains Mine No. 1 plans to resume mining of the same area. No new coal mines or other industrial developments are known to be proposed for the Project study area.

Infrastructure Development

Roads

Portions of U.S. Route 87 between Roundup and Billings were upgraded during the 1990s. The only known proposed future upgrades are the construction of acceleration-deceleration lanes where Old Divide Road (the proposed access road to the Project study area) intersects Route 87.

Transmission

The major backbone of the Montana transmission system is the two 500kV lines that run east to west across the state and through the Broadview Substation (the Project connection point). The 500kV lines connect to the Bonneville Power Administration (BPA) system at Garrison Substation, west of Broadview Substation. Additionally, 230kV transmission connects Broadview Substation to the PacifiCorp system at Yellowtail Substation southwest of the Project study area.

According to BPA, major transmission improvements to the BPA system are planned. These improvements would include substation upgrades and transmission line additions between Montana and the Pacific Northwest.

The transmission lines from the Project would be inside the existing railroad right-of-way for the Mine railroad to Broadview Substation, where the lines would connect to the NorthWestern Energy system. No additional land would be disturbed.

Consultation and Coordination

In addition to the public and agency scoping process, federal, state, and local agencies with an interest in the Project or the Project study area were contacted and asked to provide comments about the Project, identify issues that would need to be addressed, and supply data, information, and/or mapping. On April 4, 2002, a public scoping meeting was held by the DEQ in the City of Roundup. Public comments were also accepted by mail during the scoping period from March 20

to April 19, 2002. On October 18, 2002, a letter was sent to the Project mailing list stating that an EIS was being prepared. The letter also asked that EIS reviewers contact DEQ to request a copy of either a compact disk (CD) or hardcopy of the EIS, or just this Executive Summary.

Table of Contents

Chapter 1 Purpose and Need	1-1
1.1 Introduction	1-1
1.2 Proposed Agency Action	1-1
1.3 Purpose and Need for the Action	1-1
1.3.1 Benefits of the Project	1-5
1.4 Authorizing Actions, Statutes, and Consultations	1-6
1.5 Issues to be Addressed	1-8
1.5.1 Socioeconomic Effects	1-8
1.5.2 Air Quality	1-8
1.5.3 Water Resources	1-9
1.5.4 Noise	1-9
1.5.5 Infrastructure	1-9
1.5.6 DEQ Regulatory Actions and Response	1-9
CHAPTER 2 DESCRIPTION OF THE PROPOSED ACTION AND ALTERNATIVES	2-1
2.1 Overview	2-1
2.2 Proposed Action	2-1
2.2.1 Project Facilities	2-2
2.2.2 System Design	2-10
2.2.3 Additional Auxiliary Equipment	2-24
2.2.4 Construction	2-28
2.2.5 Mitigation Measures	2-38
2.3 Alternatives Considered and Eliminated	2-42
2.3.1 Alternative Fuel Sources	2-42
2.3.2 Alternative Water Supplies	2-42
2.3.3 Alternative Cooling Systems	2-45
2.3.4 Alternative Combustion Systems	2-45
2.3.5 Alternative Solid Waste Systems	2-47
2.3.6 Alternative Wastewater Discharge Systems	2-48
2.3.7 Alternative Emissions Control Systems—Main Boiler	2-48
2.3.8 Alternative Generation Sites	2-49
2.4 Alternatives to the Proposed Action	2-50
2.4.1 Landfill Alternative	2-50
2.4.2 230kV Transmission System Alternative	2-53
2.4.3 No-Action Alternative	2-53

2.5	Comparison of Alternatives	2-53
2.6	Selection of the Preferred Alternative	2-54
Chapter 3 Affected Environment		3-1
3.1	Introduction	3-1
3.2	Air Resources	3-1
3.2.1	Overview	3-1
3.2.2	Inventory Methods	3-2
3.2.3	Inventory Results	3-2
3.3	Water Resources	3-12
3.3.1	Overview	3-12
3.3.2	Inventory Methods	3-12
3.3.3	Inventory Results	3-13
3.4	Earth Resources	3-14
3.4.1	Overview	3-14
3.4.2	Inventory Methods	3-15
3.4.3	Inventory Results	3-15
3.5	Botanical and Wetland Resources	3-23
3.5.1	Overview	3-23
3.5.2	Inventory Methods	3-23
3.5.3	Inventory Results	3-23
3.6	Wildlife Resources	3-28
3.6.1	Overview	3-28
3.6.2	Inventory Methods	3-28
3.6.3	Inventory Results	3-28
3.7	Fisheries and Aquatic Resources	3-31
3.7.1	Overview	3-31
3.7.2	Inventory Methods	3-32
3.7.3	Inventory Results	3-32
3.8	Cultural Resources	3-33
3.8.1	Overview	3-33
3.8.2	Inventory Methods	3-34
3.8.3	Inventory Results	3-35
3.9	Visual Resources	3-36
3.9.1	Overview	3-36

3.9.2	Inventory Methods	3-36
3.9.3	Inventory Results	3-39
3.10	Noise	3-45
3.10.1	Overview	3-45
3.10.1	Noise Level Criteria	3-46
3.10.3	Noise Inventory Results	3-47
3.11	Land Use	3-53
3.11.1	Overview	3-53
3.11.2	Inventory Methods	3-53
3.11.3	Inventory Results	3-53
3.12	Socioeconomics	3-61
3.12.1	Overview	3-61
3.12.2	Socioeconomic Methods	3-61
3.12.3	Socioeconomic Results	3-61
Chapter 4 Environmental Consequences		4-1
4.1	Introduction	4-1
4.1.1	Impact Assessment Methods	4-1
4.2	Air Resources	4-2
4.2.1	Methods	4-2
4.2.2	Proposed Action	4-6
4.2.3	Action Alternatives	4-22
4.2.4	Mitigation Measures	4-24
4.2.5	No-Action Alternative	4-25
4.3	Water Resources	4-25
4.3.1	Methods	4-25
4.3.2	Proposed Action	4-27
4.3.3	Action Alternatives	4-30
4.3.4	Mitigation Measures	4-30
4.3.5	No-Action Alternative	4-31
4.4	Earth Resources	4-31
4.4.1	Methods	4-31
4.4.2	Proposed Action	4-32
4.4.3	Action Alternatives	4-35
4.4.4	Mitigation Measures	4-35
4.4.5	No-Action Alternative	4-37
4.5	Botanical and Wetland Resources	4-37
4.5.1	Methods	4-37
4.5.2	Proposed Action	4-38

4.5.3	Action Alternatives	4-43
4.5.4	Mitigation Measures	4-44
4.5.5	No-Action Alternative	4-44
4.6	Wildlife Resources	4-44
4.6.1	Methods	4-44
4.6.2	Proposed Action	4-46
4.6.3	Action Alternatives	4-47
4.6.4	Mitigation Measures	4-47
4.6.5	No-Action Alternative	4-48
4.7	Fisheries and Aquatic Resources	4-48
4.7.1	Methods	4-48
4.7.2	Proposed Action	4-49
4.7.3	Action Alternatives	4-50
4.7.4	Mitigation Measures	4-50
4.7.5	No-Action Alternative	4-50
4.8	Cultural Resources	4-50
4.8.1	Methods	4-50
4.8.2	Proposed Action	4-52
4.8.3	Action Alternatives	4-54
4.8.4	Mitigation Measures	4-55
4.8.5	No-Action Alternative	4-55
4.9	Visual Resources	4-55
4.9.1	Methods	4-55
4.9.2	Proposed Action	4-58
4.9.3	Action Alternatives	4-61
4.9.4	Mitigation Measures	4-61
4.9.5	No-Action Alternative	4-62
4.10	Noise	4-62
4.10.1	Methods	4-62
4.10.2	Proposed Action	4-64
4.10.3	Action Alternatives	4-73
4.10.4	Mitigation Measures	4-74
4.10.5	No-Action Alternative	4-74
4.11	Land Use	4-74
4.11.1	Methods	4-74
4.11.2	Proposed Action	4-75
4.11.3	Action Alternatives	4-79
4.11.4	Mitigation Measures	4-80
4.11.5	No-Action Alternative	4-80
4.12	Socioeconomics	4-80

4.12.1	Methods	4-80
4.12.2	Population and Housing	4-81
4.12.3	Employment	4-86
4.12.4	Taxes	4-89
4.12.5	Education Services	4-90
4.12.6	Transportation	4-91
4.12.7	Utilities	4-92
4.12.8	Health and Safety	4-92
4.12.9	Well Being	4-93
4.12.10	Summary of Socioeconomic Impacts	4-95
4.12.11	Mitigation Measures	4-96
4.13	Irreversible and Irrecoverable Commitment of Resources	4-96
4.14	Cumulative Impacts	4-97
4.14.1	Overview	4-97
4.14.2	Impacts to Resources	4-99
Chapter 5 Consultation and Coordination		5-1
5.1	Introduction	5-1
5.2	Agency Consultation and Coordination	5-1
5.3	Public Consultation and Coordination	5-2
5.4	Native American Consultation and Coordination	5-3
Chapter 6 List of Preparers		6-1
Chapter 7 References		7-1
Chapter 8 Acronyms and Glossary		8-1
APPENDIX A Draft Air Quality Permit		A-1
APPENDIX B Detailed Cumulative Visibility and PSD Class i increment analyses		B-1

Tables

Table 1-1	Federal, State, Local Permits, Approvals, and Authorizing Actions	1-6
Table 2-1	Preliminary List of Major Constituents in the Fly Ash and Bottom Ash	2-17
Table 2-2	Electrical Design Characteristics of the Project	2-21
Table 2-3	161kV Transmission Line Construction – Estimated Personnel and Equipment	2-32
Table 2-4	Comparison of Alternatives Considered but Eliminated	2-63
Table 2-5	Alternatives Comparison Summary	2-77
Table 3-1	Generation Plant Study Area Temperature and Precipitation	3-3
Table 3-2	Ambient Air Quality Standards	3-7
Table 3-3	Air Quality Monitoring Data	3-8
Table 3-4	Particulate Monitoring Data ($\mu\text{g}/\text{m}^3$)	3-9
Table 3-5	Major Nearby Facilities	3-11
Table 3-6	Site Stratigraphy	3-17
Table 3-7	Soils Engineering Properties and Classifications: Generation Plant Study Area, Musselshell County, Montana	3-18
Table 3-8	Soils Series Descriptions, Roundup Power Project Disturbance Area	3-19
Table 3-9	Vegetation Community Types	3-27
Table 3-10	Visual Sensitivity Criteria	3-38
Table 3-11	Visual Sensitivity Matrix	3-38
Table 3-12	Transmission System Viewer Inventory	3-44
Table 3-13	Changes in Noise Levels Versus Apparent Changes in Loudness	3-47
Table 3-14	Noise-Sensitive Receptors	3-47
Table 3-15	Measured Ambient Noise Levels Near Receptor Locations Before Construction of the Bull Mountains Mine No. 1 and Railroad	3-49
Table 3-16	Approximate Ldn Levels at Receptor Locations Due to the Operation of the Bull Mountains Mine No. 1 and Railroad	3-50
Table 3-17	1990 and 2000 Population - Musselshell and Yellowstone Counties and Selected Areas	3-61
Table 3-18	Population by Age: Bull Mountains Study Area	3-62
Table 3-19	Baseline Economic Projections for Montana, Musselshell County, and Yellowstone County, 2000 to 2020	3-63

Table 3-20	Employment by Broad Industry Musselshell County Years 1970-1999	3-65
Table 3-21	Employment in Montana, Musselshell County, and Yellowstone County- 1990 and 1999	3-68
Table 3-22	Labor Force Statistics Montana, Musselshell County, and Yellowstone County (Selected Years, 1970-2000)	3-69
Table 3-23	Per Capita Personal Income, Montana, Musselshell and Yellowstone Counties, 1990 and 1999	3-70
Table 3-24	County and Local Government Revenue and Expenses 1997	3-70
Table 3-25	Taxable Valuation, Tax Mill and Property Taxes Billed Yellowstone and Musselshell Counties and Selected Cities 1999-2000	3-71
Table 3-26	Enrollment by District and School Musselshell and Yellowstone Counties 1990-91 and 2000-01	3-71
Table 3-27	School Enrollment by Grade, Musselshell County 2000-01	3-73
Table 4-1	National and Montana Ambient Air Quality Standards, PSD Increments and PSD Significance Levels	4-3
Table 4-2	Class I Visibility and Acid Deposition Significance Levels	4-4
Table 4-3	Plant-Wide Source Emission Summary	4-6
Table 4-4	Boiler HAP Emission Inventory	4-7
Table 4-5	Review of BACT Analysis	4-8
Table 4-6	Proposed BACT Emission Limits and Control Technologies	4-9
Table 4-7	Proposed MACT Technology	4-11
Table 4-8	Modeling Parameters and Emission Rates for Roundup Power Project Point Sources	4-13
Table 4-9	Radius of Impact Analysis Results	4-14
Table 4-10	Visibility Analysis Results for the Roundup Power Project	4-16
Table 4-11	Class I Increment Impacts	4-17
Table 4-12	CALPUFF Modeling Deposition Results	4-18
Table 4-13	Nitrogen and Sulfur Deposition at Critical Class II Receptors Near Yellowstone National Park	4-18
Table 4-14	Existing Ambient Air Quality Concentrations Values	4-19
Table 4-15	Screening Analysis for Heavy Metal Deposition in Soils	4-20
Table 4-16	Estimated Roundup Power Project Greenhouse Gas Emissions	4-21
Table 4-17	Estimated Greenhouse Gases in US and from the Project	4-22
Table 4-18	Summary of Potential Impacts to Air Resources	4-23

Table 4-19	Summary of Impacts on Geology and Soils from Construction and Operation of the Proposed Roundup Power Project	4-33
Table 4-20	Summary of Impacts on Vegetation from Construction and Operation of the Generation Plant	4-40
Table 4-21	Affected Acres by Vegetation Type for the Generation Plant Study Area	4-41
Table 4-22	Resources Within the Viewshed	4-53
Table 4-23	Distance Zones	4-57
Table 4-24	Viewer Impacts	4-57
Table 4-25	Visual Influence of Project Chimneys	4-59
Table 4-26	Roundup Power Project Noise Sources	4-65
Table 4-27	Day Average Noise Levels Due to the Power Project	4-66
Table 4-28	Night Average Noise Levels Due to the Power Project	4-66
Table 4-29	Predicted Day-Night Noise Levels Due to the Power Project	4-67
Table 4-30	Summary of Impacts on Noise Levels from Construction and Operation of the Project	4-68
Table 4-31	Summary of Impacts on Land Use from Construction, Operation, and Maintenance of the Proposed Roundup Power Project	4-79
Table 4-32	Economic Projection Parameters	4-81
Table 4-33	Projected Direct and Secondary Employment, Labor Income, and Population Associated with the Roundup Power Project Musselshell and Yellowstone Counties	4-82
Table 4-34	Projected Direct and Secondary Employment, Labor Income and Population Associated with the Bull Mountains Coal Mine Project Musselshell and Yellowstone Counties	4-83
Table 4-35	Projected Direct and Secondary Employment, Labor Income and Population Associated with the Bull Mountains Coal Mine and Roundup Power Project Together Musselshell and Yellowstone Counties	4-84
Table 4-36	Baseline Economic Projections for Montana, Musselshell County, and Yellowstone County 2000 to 2020	4-88
Table 4-37	Summary of Socioeconomic Impacts	4-95
Table 4-38	Potential Emissions from Billings/Laurel SO ₂ Emission Sources	4-99
Table 4-39	Cumulative NAAQS/MAAQs Impacts	4-100
Table 4-40	Cumulative PSD Class II Increment Impacts	4-101

Figures

Figure 1-1	Vicinity Map	1-3
Figure 2-1	Visual Simulation Looking North	2-3
Figure 2-2	Plant Layout	2-5
Figure 2-3	Site Design	2-7
Figure 2-4	Schematic Diagram of the Equipment	2-11
Figure 2-5	Generation Plant Water Balance Diagram	2-13
Figure 2-6	Transmission Line Design	2-23
Figure 2-7	Preliminary Roundup Project Schedule	2-29
Figure 2-8	H-Frame Transmission Line Structure Assembly	2-36
Figure 2-9	Transmission Line Wire Pulling	2-37
Figure 2-10	Alternative Solid Waste Disposal Area	2-51
Figure 2-11	Transmission System	2-57
Figure 3-1	Billings WSO, Montana, Wind Rose, 1986-1990	3-5
Figure 3-2	Class I Areas of Concern for the Roundup Power Project	3-11
Figure 3-3	Soils	3-21
Figure 3-4	Vegetation	3-25
Figure 3-5	Sensitive Views	3-41
Figure 3-6	Noise	3-51
Figure 3-7	Land Use	3-55
Figure 4-1	Noise Contours	3-71

CHAPTER 1

PURPOSE AND NEED

1.1 Introduction

This chapter describes the proposed agency action and a brief description of the purpose, need, and benefits of the proposed Roundup Power Project (Project). All necessary permits, licenses, and authorizations associated with the Proposed Action are also identified. In addition, the public participation process and issues of concern raised during the scoping process are summarized.

The Project is a proposed coal-fired electric generation facility located on private property about 35 miles north of Billings and 13 miles south-southeast of Roundup, Montana. A map of the proposed Project Area is shown in Figure 1-1. The Project is designed to be a mine-mouth facility using coal from the existing Bull Mountains Mine (Mine) located adjacent to the Project. To meet its coal supply needs, the Project proponent has entered into contractual agreements with the Mine to purchase approximately 2.7 million tons of coal per year. Coal would be delivered from the Mine to the Generation Plant by a conveyer system. A new 161 kilovolt (kV) transmission system, approximately 30 miles long, would be built from the Generation Plant to NorthWestern Energy's Broadview Substation, interconnecting with the northwest transmission network. Power generated by this facility would be sold to all classes of electricity consumers (residential, municipal, cooperative, commercial, and industrial customers).

1.2 Proposed Agency Action

The action required by the Montana Department of Environmental Quality (DEQ) is to make a decision to issue or deny the necessary DEQ-authorized permits to construct and operate the Project. The primary DEQ authorization is granting a Final Air Quality Permit to the Project proponent. This permit action is required under the Montana Clean Air Act 75-2-201 et seq., Montana Code Annotated (MCA), and Administrative Rules of Montana (ARM) 17.8.701 et seq. All necessary permits, licenses, and authorizations required for the Project by the DEQ and other state, federal, and local authorities are listed in Table 1-1. This environmental impact statement (EIS) is being prepared to comply with the Montana Environmental Policy Act of 1971 (MEPA), as modified by subsequent legislation. The EIS focuses on major actions resulting from the Proposed Action that may have significant impacts on the human environment.

1.3 Purpose and Need for the Action

The primary needs for the Project are to serve population growth, load growth, and the need for new base load electrical generation. The population of the United States is growing by several million households per year through internal population growth and immigration. Recent (2000) census data indicate that the population of the western United States grew approximately 1.6 percent from 1990 to 1999, outstripping the growth averaged over the United States.

The Project would provide a new source of electricity in a region where energy supplies have not kept up with the growth of demand. The Western Electric Coordinating Council (WECC; formerly the Western System Coordinating Council or WSCC) produces an annual report on the reliability and adequacy of the power system in the western United States (WECC, 2002). Montana is part of an area identified by WECC as the Northwest Power Pool Area (NWPP), which includes most of Montana and Nevada and all of Idaho, Oregon, Washington, and Utah, as well as parts of western Colorado, northern California, and western Canada. The current ten-year projections have indicated the demand for electricity for the NWPP will grow from the approximately 50,000MW of demand recorded in 2001 to as much as 65,000MW in 2011. That population and electrical demand growth, together with the retirement of older, less efficient electrical generating units, requires the continued development of new and cleaner generation sources. The Project would fill a portion of this need.

Power output would be used by the owners for their internal use. A small portion may be sold into the wholesale power market within the interconnected grid of the WECC when not needed by the owners. The WECC projects that peak demand within the western United States will increase from the approximately 120,000MW recorded in 2001 to approximately 165,000MW in 2011. While the demand for electricity has weakened somewhat since the economic downturn starting in late 2000, the demand for power will likely continue its upward trend following economic recovery. This Project fits into the expected future economic growth and need for new sources of clean, economical power.

The recent downturn in the economy followed a period of unprecedented expansion in the economy of the United States and rapid growth in the demand for electricity to support industrial and technological expansion. Expansion of the power generation and transmission infrastructure in the United States is supported by government energy agencies, as this is thought to be the only means to avoid crisis and shortfalls for the next period of economic expansion. Continual reliance on a sagging and aging infrastructure is a concern and may be a problem in the future unless positive action is taken with infrastructure expansion, such as that proposed by the Project.

The power industry has been under intense restructuring starting with the approval of the Public Utility Regulatory Policies Act of 1978, which introduced the concept of private generators to be a part of the wholesale power market. To reduce the effects of the regulated monopolies that had historically been the utilities, this act required utilities to purchase power from “qualified facilities.” A number of other Federal Energy Regulatory Commission (FERC) Orders and Congressional actions have followed in an attempt over the past decade to examine restructuring transmission and further encourage private development in the power generation market.

The generation market is presently restructured to a large degree with most power plants owned by unregulated power companies. Many developers of gas-fired generation facilities have proposed projects in various parts of the western United States, and some of these projects have been or are being constructed. Uncertainties for fuel sources, intense gas price fluctuation, and intense competition have limited the number of power plants that have gone into commercial operation. Coal-fired power plants have many advantages over gas-fired combustion turbine projects such as having stable fuel supplies and prices. Other electrical energy needs are filled by renewable fuel sources, hydroelectric and nuclear generation, and through conservation and demand-side management techniques. All of these sources play an important role in meeting the energy demands of the United States.

Figure 1-1 Vicinity Map

The Project would be built specifically to burn coal. The mine-mouth fuel source of the Project would provide stable pricing and reliability for base load power that is needed by the utilities to reliably serve industrial, commercial, and residential customers. Coal is currently the fuel for more than 50 percent of the electricity generated in the United States and 37 percent of the world, although new coal-fired power plants have not been constructed for nearly two decades in the United States.

The Project also would increase the opportunity for competition in the regional energy market by increasing the total amount of electricity that could be transmitted reliably within the grid. Competition in the power marketplace is viewed as the best means in a market economy to keep power pricing in line with customer demand and need and competitive pricing of industrial production and output. Competition in the marketplace is also expected to result in system redundancy and reliability that was formerly found and maintained in the regulated industry.

Utilities are facing increased electricity demands and changes in electricity suppliers because of regulatory changes that have occurred in the United States over the past few years. The Project would supply electricity for wholesale use by the Project owner utilities (private, municipal, and cooperative) for sale to the utilities' industrial, commercial, and residential electricity consumers. It is possible that excess power could be sold from time to time by the owners into the wholesale spot market, however, it is the primary intent of the Project owners to obtain base load energy for their own power supply portfolios.

The purpose of the Project in the proposed location is to take advantage of a reliable, cost-effective, and high-quality coal source to fuel the Project. The purpose of the associated transmission line to the Broadview Substation is to provide a reliable interconnection to the interconnected transmission grid in the western United States. Some of the electricity could be consumed by industrial, commercial, and residential customers in Montana. NorthWestern Energy currently is evaluating the interconnection of the Project with their transmission system.

1.3.1 Benefits of the Project

The benefit of the Project would be a stable, reliable, low-cost supply of electricity in a region that has had uncertain supply and prices in recent years. The Project would have a low-cost, stable, and high-quality fuel source (i.e., coal with high heating value and low sulfur content) for the life of the Generation Plant in the form of the Mine, located within a mile of the Generation Plant Study Area. The Project would not be subject to the uncertainties and recent water supply issues that have affected hydroelectric generation, and the swings in fuel prices and supply that have occurred for natural-gas-fueled plants.

This known and stable electricity source could allow Montana to attract business and to develop its economy. Business is attracted by stable and assured operating costs and conditions. For many businesses, electricity is a major concern and expense.

The Project would be an industrial facility that would convert a raw material (coal) to a higher value product (electricity). The coal from the adjacent Mine would ultimately be converted to electricity and is, therefore, a benefit to Montana to receive the investment, the tax-base increases, and the jobs that would be created by the construction, long-term operation of the facility, and the support systems and economic development. In this respect, this facility would not be any different from other industrial facilities. An automobile assembly plant or a computer

manufacturing facility also would create jobs, attract investment, and generate taxes, with the products being both consumed in the state and exported.

1.4 Authorizing Actions, Statutes, and Consultations

MEPA requires an environmental review whenever a state agency intends to issue a lease, permit, license, certificate, or other entitlement for use or permission to act by the agency, either singly or in combination with other state agencies (75-1-201, MCA). On January 14, 2002, a formal application for an Air Quality Permit was submitted by the Project proponent with the DEQ to meet requirements of the Montana Clean Air Act (75-2-201 et seq., MCA and ARM 17.8.701 et seq.). The application was deemed “filed” on July 22, 2002, starting the 180-day time frame for the associated MEPA process with DEQ as the lead agency.

Additional permit requirements associated with the Project are included in Table 1-1. The Project proponent, because of its desire to be responsive to the concerns of the public and to be proactive in addressing any potential concerns, voluntarily elected to have the Project fully evaluated and assessed pursuant to a comprehensive EIS under MEPA. DEQ has determined that an EIS is the appropriate form of environmental review due to the potential for significant impacts from agency actions and resultant Project-sponsored activities.

Table 1-1 Federal, State, Local Permits, Approvals, and Authorizing Actions

Issuing Agency	Permit/ Approval Name	Nature of Permit	Authority
Federal Government			
Federal Aviation Administration	Notice of Proposed Construction or Alteration	Tower location and height relative to air traffic corridors	49 USC 1501; 13 CFR 77, Objects affecting navigable air space
U.S. Army Corps of Engineers	Section 404 Permit (Clean Water Act) Nationwide Permit/Individual Permit	Controls discharge of dredged or fill materials in wetlands and other waters of the U.S.	Section 404 of the Clean Water Act (33 CFR 323.1)
State Government			
Montana DEQ	Section 401 Water Quality Certification	Provides a review of potential adverse water quality impacts potentially associated with discharges of dredged or fill materials in wetlands and other waters of the U.S.	Montana Water Quality Act (75-5-401 et seq., MCA)

Issuing Agency	Permit/ Approval Name	Nature of Permit	Authority
Montana DEQ	General Permit for Storm Water Discharges Associated with Construction Activity	Submit Notice of Intent for coverage under General Permit to authorize storm water discharges to surface waters of the state associated with the construction activities	Montana Water Quality Act (75-5-101 et seq., MCA) Montana Water Quality Act (75-5-401 et seq., MCA)
	General Permit for Storm Water Discharges Associated with Industrial Activity	Apply for coverage under General Permit in order to authorize storm water discharges to surface waters of the state associated with the operation of the Generation Plant	Montana Water Quality Act (75-5-101 et seq., MCA) Montana Water Quality Act (75-5-401 et seq., MCA)
	Montana Ground Water Pollution Control System (MGWPCS)	Permit to discharge sewage effluent into the groundwater system via a permitted wastewater system	75-5-101, MCA 17.30.1341 ARM 17.30.1042 ARM
	Air Quality Preconstruction Permit	Permit for the construction, installation and operation of equipment or facilities that may directly or indirectly cause or contribute to air pollution	75-2-211, MCA: Pre-construction permit
	Air Quality Operating Permit	Permit for the construction, installation and operation of major equipment or major facilities that may directly or indirectly cause or contribute to air pollution	75-2-217, MCA: Operating permit
Montana Department of Natural Resources and Conservation	Beneficial Water Use Permit	Would allow use of groundwater for the Generation Plant and related facilities	85-2-311 MCA Water Right Permit
Montana Department of Transportation	Utility Crossing Permit	Grant state highway utility crossing permits for transmission line and access roads that may encroach on state highway rights-of-way	RW131 and/or RW20
Montana State Historic Preservation Office	Section 106 of the National Historic Preservation Act	Consults with project applicants and state agencies regarding impacts on cultural resources that are either listed or eligible for listing on the National Register of Historic Places	National Historic Preservation Act
Local Government			
County Weed Control Districts	Noxious weed management program	Provides containment, suppression, and eradication of noxious weeds	Title 7 (7-22-2101-2153, MCA)

Issuing Agency	Permit/ Approval Name	Nature of Permit	Authority
Boards of County Commissioners	Easement grants and road-crossing permits	Consider issuance of right-of-way and road-crossing permits for county property and roadways	

1.5 Issues to be Addressed

Before preparation of the EIS, DEQ invited the participation of affected federal, state, and local government agencies, Indian tribes, Project sponsors, and interested persons and groups to discuss issues, concerns, and opportunities, and to help identify the scope of the EIS. During this scoping process, DEQ also identified possible alternatives to the Proposed Action. Government agencies that participated in the scoping process and preparation of the EIS are identified in Chapter 6. Agencies and stakeholders specifically contacted for input are identified in Chapter 5. Alternatives to the Proposed Action are described in Chapter 2.

On April 4, 2002, a public scoping meeting was held by the DEQ in the City of Roundup. The purpose of this meeting was to identify issues and concerns that the public believed needed to be analyzed in the environmental review under MEPA. Comments on the scope of the MEPA review were also accepted by mail. In addition, the owners of the Project have sought public participation by making three presentations to the Legislature's Transition Advisory Committee, by participating in the Governor's Conference on Economic Development on March 7, 2002, in Billings, and by making a presentation to the executive board of the Big Sky Economic Development Authority in Billings.

The issues of concern raised during the EIS scoping process and federal and state resource management agencies are listed below.

1.5.1 Socioeconomic Effects

- Impacts on schools, law enforcement, and other public services due to in-migration of Generation Plant workers.
- Changes in social setting and attitudes due to in-migration of Generation Plant workers.
- Impacts associated with increased traffic.
- Infrastructure impacts.

1.5.2 Air Quality

- Air quality impacts due to pollution emissions during Generation Plant operation.
- Global climate impacts due to greenhouse gas emissions during Generation Plant operation.
- Cumulative impacts.

1.5.3 Water Resources

- Impacts on surface water or groundwater quality due to solid waste disposal and other Generation Plant activities.
- Impacts on groundwater levels and supplies due to withdrawals during Generation Plant operation.

1.5.4 Noise

- Disturbance of nearby residents by noise from Generation Plant construction and operation.

1.5.5 Infrastructure

- Adequacy of existing transmission system to carry the Generation Plant output.

1.5.6 DEQ Regulatory Actions and Response

- Evaluation/regulation for combined impacts of the Generation Plant and other industrial developments in the region.
- Monitoring of the Generation Plant construction process, including depth of groundwater wells.
- Response to Generation Plant emissions exceedances of permitted levels, accidents during Generation Plant operations and issues involving the proposed landfill.

CHAPTER 2

DESCRIPTION OF THE PROPOSED ACTION AND ALTERNATIVES

2.1 Overview

This section describes the process of developing and selecting reasonable alternatives to the Proposed Action. To be considered for further study, each potential alternative had to meet the purpose of and need for the Roundup Power Project (Project) as well as meet technical, environmental, and economic feasibility criteria. A wide range of alternatives were evaluated and placed into the following categories:

- Proposed Action – describes the proposal and the activities needed to implement it.
- Alternatives Considered and Eliminated – describes what alternatives were briefly examined but eliminated from detailed study. Alternatives discussed include fuel sources, water supplies, waste stream treatment, disposal alternatives, and alternative generation sites.
- Alternatives to the Proposed Action including No-Action – identifies alternatives that are reasonable and that would support the purpose and need of the Proposed Action. The alternatives must also be feasible from a technical and economic standpoint.

The No-Action alternative discusses the current situation by assuming the air quality permit would not be issued and the Generation Plant would not exist at this or any other location.

2.2 Proposed Action

The Proposed Action includes the granting of DEQ permits and licenses described in Chapter 1, Table 1-1 and the resultant construction and operation of the Project as it has been proposed. The following sections summarize the Proposed Action.

The Project is located in Musselshell County, approximately 35 miles north of Billings and 13 miles south of Roundup, Montana. The site is east of U.S. Route 87 and north of Old Divide Road. Approximately 167 acres of private land would be located within the plant fence. An additional 40 acres of private land would be utilized outside the fenced area for additional Project facilities. Figure 1-1 presents an overview of the Project including the Generation Plant and Transmission System.

The proposed site is located in the NW¹/₄ SE¹/₄ of Section 15, Township 6 North, and Range 26 East. Universal Transverse Mercator (UTM) coordinates for the site center are Zone 12, Easting 696.25 kilometers (432.60 miles), and Northing 5,126.87 kilometers (3,185.69 miles).

Unless otherwise cited, a description of all proposed Project activities can be found in the original Project proponent submittals. The original application for an air quality permit was submitted to DEQ on January 14, 2002, and accepted as filed on July 22, 2002. The draft air quality permit was issued on August 12, 2002. The proponent's Environmental Impact Statement (EIS) Support Document (Bull Mountain Development Company, LLC., 2002a) was submitted to DEQ in May 2002.

2.2.1 Project Facilities

The Project would consist of two electric generating units, each with a pulverized coal-fired boiler and a steam turbine generator. Each unit would be designed to generate a nominal 390 megawatts (MW) gross (350 MW net) electrical capacity year-round on a 24-hour-per-day basis, except during planned maintenance periods and occasional repair outages when one unit would normally remain operating.

In addition to the generating units, the following associated facilities are planned:

- Four to six groundwater wells, approximately 8,500 feet deep, are to be constructed for the plant water supply.
- Three circuits of 161 kilovolt (kV) electrical transmission lines would connect from the generation facility approximately 28.2 miles southwest to NorthWestern Energy's Broadview Substation. The route for the transmission lines would be within or immediately adjacent to the Bull Mountains Mine's (Mine's) rail corridor.
- Coal to fuel the Generation Plant would be delivered by an approximately 4,000-foot-long conveyor belt from the Mine transition point.

Air pollution emissions, wastewater discharges, solid waste disposal, and other significant aspects of the Project would comply with applicable permits and environmental requirements. In addition, the Generation Plant would be constructed in accordance with American Society of Mechanical Engineers (ASME) standards for power plants and the National Boiler Board Rules. American National Standards Institute (ANSI) standards and steel construction standards would be adopted for structural, tank, and concrete work. State and federal building codes and standards and local industrial requirements would also be followed. Fire and safety codes would be adhered to for the affected sections of the National Fire Protection Agency (NFPA) concerned with various fire classifications. Occupational Safety and Health Administration (OSHA) standards would be followed regarding Generation Plant operations. Other regulations and design codes would be followed, as applicable. The Project final design drawings and procurement specifications would be provided by engineering specialists in power generation and transmission projects.

Initial Generation Plant planning and the development of the conceptual design have incorporated a number of enhancements relative to the Project. The selection of the most suitable equipment consisted of balancing the investment, operating characteristics, efficiency, and the type of coal that would combine to give the most economical installation. The conceptual design of the plant also incorporates state-of-art pollution control equipment that achieves low environment impacts and complies with all applicable regulations.

A visual simulation of the proposed Generation Plant is provided in Figure 2-1. The main Generation Plant features shown are the plant building, the air-cooled condensers, and the two chimneys (one for each unit). The colors selected for the structures are intended to blend with the surroundings, except for the chimneys in which the colors selected would meet aviation safety requirements.



Figure 2-1 Visual Simulation Looking North

The Plant Layout depicting all major facilities is shown on Figure 2-2. This drawing shows the two turbine and boiler buildings, flue gas treatment equipment with two chimneys, air-cooled condensers, transformers and other major equipment. The offices, control room, warehouse, shop, and water treatment equipment are also shown. This area would be enclosed with a perimeter fence.

Equipment and systems such as the air-cooled condenser, transformers, switchyard, water and demineralized water storage tanks, water treatment building, storm water detention pond, plant area northwest of power block, plant area south of the power block, coal pile runoff sedimentation pond, wastewater holding pond, and landfill leachate collection pond would be located outside the boiler room and turbine room building power block complex. Administration offices, control room, warehouse, and gatehouse are also located adjacent to the power block complex. Figure 2-3 shows the overall site design and layout.

The boiler, turbine, and most of the other equipment would be located within the main building. The equipment includes the feed water heaters, condensate and boiler feed pumps, boiler coal pulverizers, primary air fans, combustion air heaters, and bottom ash hopper. The equipment would be large compared to most industrial equipment found in an industrial park setting, but the boiler and turbines for this plant would be about one-third the size of the largest boilers and turbines in the power industry. The control room, electronics area, and electrical switching equipment also would be located in the building.

Project Lands

It is estimated that the total area disturbed during construction would be about 208 acres. About three inches of topsoil would be stripped from the entire disturbed area, resulting in approximately 84,700 cubic yards of soil to be stockpiled at a height of 10 feet to 15 feet. Most of the topsoil would be spread on slopes, ditches, and pond dikes as soon as the grading in those areas is completed.

Some of the stored topsoil would be used to cover solid waste landfill cells. The landfill would be designed to hold 10 years of solid waste and because it would not likely receive waste continuously during the first 10 years of plant operation, some of that topsoil could be stored for many years. Topsoil would be spread on the landfill cell vegetation cover layers at a minimum depth of six inches.

Roads and Parking Areas

The Generation Plant access road (approximately 0.2 mile long) would be surfaced with asphalt pavement. Roads around the immediate Generation Plant Study Area also would be surfaced with asphalt concrete. Other service and maintenance roads within the Generation Plant would be surfaced with crushed rock. The road to the solid waste disposal area would be 50 feet wide, surfaced with crushed rock, and would be designed for heavy haul trucks. A 10.6-acre construction parking lot and a 13.5-acre area covered with crushed rock would be provided for construction trailers, tools, vehicles, equipment, and material construction storage and laydown.

Plant Buildings and Structures

Plant buildings and structures include the following:

Main building plan area	200 feet x 260 feet
Turbine room portion of building	120 feet tall
Boiler room portion of building	250 feet tall
Training, control, support facilities (adjacent building attached to main building)	65 feet tall x 100 feet x 70 feet
Water treatment, maintenance shop, parts storage, main locker room	35 feet tall x 120 feet x 265 feet
Air compressor building	20 feet tall x 35 feet x 70 feet
Coal conveyor transfer house	50 feet tall x 30 feet x 30 feet
Coal crusher building	90 feet tall x 50 feet x 80 feet
Lime preparation building	20 feet tall x 70 feet x 100 feet

Figure 2-2 Plant Layout

Figure 2-3 Site Design

Additionally, there would be small buildings for equipment such as the No. 2 fuel oil pump, fire pumps, and emergency diesel generator. These buildings mainly would have mat-and-footing-type foundations, steel structures, and insulated metal siding. The buildings would be provided to protect equipment and provide proper conditions for plant operators during inclement weather and to control equipment noise to the surrounding Generation Plant area.

Each unit would have a 574-foot-tall chimney constructed of a reinforced concrete outer shell and a corrosion resistant liner. Federal Aviation Administration (FAA) lighting and marking requirements would be met.

Mine Mouth Plant

The design of the Project is based on receiving coal from the Mine via conveyors. This design concept is called a mine-mouth plant. It is different from most coal-fired plants that receive coal by train, truck, or river barge. Shipping is often a significant cost of coal production and use in electrical generation.

The Mine would use a popular form of continuous underground mining called longwall mining. Using this technique, a continuous miner moves back and forth across a panel of coal (called a longwall) about 800 feet wide and up to 7,000 feet long. Longwall mining is performed using hydraulic roof supports that are advanced as the seam is cut. The roof behind the supports is allowed to collapse as the mining progresses.

In continuous mining, a specialized cutting machine removes coal from the wall and automatically removes it from the mine using belt conveyors. Using conveyors instead of a train or other coal transport reduces coal handling dust and fuel degradation. The noise, traffic disruption, and cost associated with railroad or other forms of shipment of coal is also eliminated or minimized. Conveyor systems are efficient, reliable, and environmentally desirable.

Operations and Maintenance

Generation Plant staffing initially would require about 100 people for the first unit operation and would increase to about 150 people when the second unit would begin operating. Initial personnel staffing of the Generation Plant would involve an intensive program of advertising, interviews, and training.

The plan would be to operate the Generation Plant 24-hours-per-day to provide its maximum electrical output throughout the year. Generation Plant operations would be monitored for staff safety, meeting environmental requirements, and providing reliable and efficient operations. Operations would focus on meeting the power output objectives and minimizing fuel and other consumables.

Planned maintenance would be coordinated to reduce the impact of having a unit shut down for maintenance and overhauls. Normally, this work would be planned during spring when the need for electricity is reduced. Usually only one of the two units would be shut down. Short maintenance periods of one to two weeks would likely occur once each year or two. Longer maintenance periods of three to five weeks for major steam turbine overhauls would probably need to occur once every six to nine years.

2.2.2 System Design

The system design consists of a boiler, turbine and associated systems, storm water and wastewater ponds, solid material storage areas, solid waste disposal areas, and material handling.

Boiler, Turbine, and Associated Systems

The Generation Plant's major components would include two similar designed units each with one pulverized coal-fired boiler, steam turbine generator, air-cooled condenser, emission control equipment, and chimney. Figure 2-4 illustrates a schematic diagram of the equipment for one of the two units. This is a modern coal plant design that uses the most recent commercially available boiler, turbine, air emission control equipment, and air-cooled condenser.

Coal fuel from the Mine would travel by conveyor to the Generation Plant area and then to storage silos adjacent to the boiler. Combustion would take place in the boiler furnace where water would be converted to steam. The forced draft fans would provide combustion air. Steam would be produced in the boiler furnace area and would be heated in convection sections of the boiler.

Steam at high pressure and temperature (2400 psig, 1005°F) from the boiler would enter the steam turbine. Steam from the high-pressure turbine section would be reheated (to 1005°F) in the boiler reheater for improved cycle efficiency. Steam would continue to flow through the turbine converting steam pressure and temperature energy to mechanical energy for turning the generator to produce electricity. When the steam would reach the lowest practical pressure (i.e., significantly below atmospheric pressure, which would result in higher cycle efficiency), it would leave the turbine and enter the air-cooled condenser.

An air-cooled condenser would be used for reduced plant water consumption. After the steam was condensed, condensate and boiler feed pumps would return the water to the boiler through the feed water heaters.

Feed water heaters would improve the cycle efficiency by heating the water before it would enter the boiler. This often-used regenerative design is called the advanced Rankine Cycle.

Makeup water (new water added to a boiler circuit) would be needed because some water and steam would be lost in the boiler, turbine, and other equipment and systems and because it would be necessary to drain (blow down) a portion of the boiler water to maintain the needed water chemistry. The makeup water would be pumped from the wells and treated in a demineralizing system.

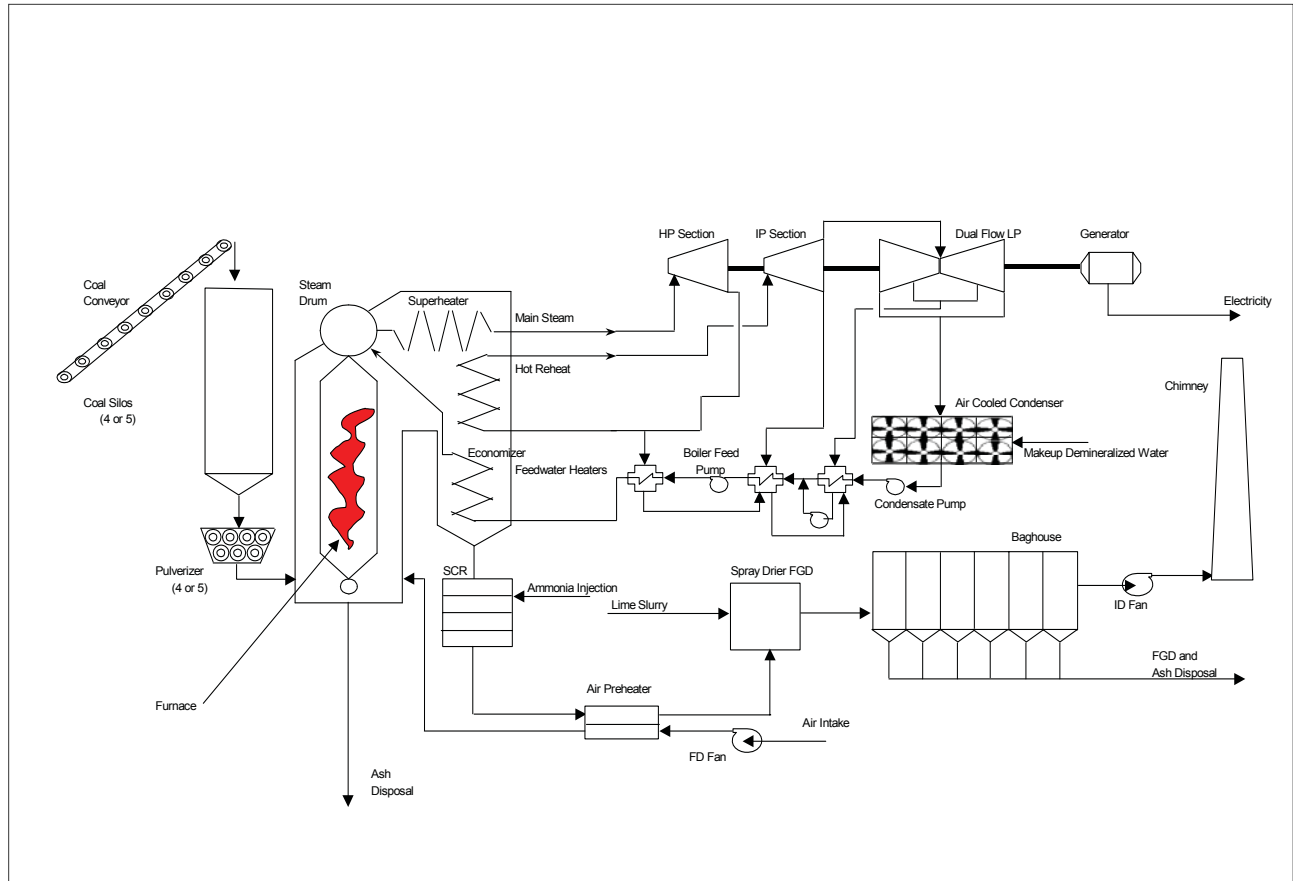

Figure 2-4 Schematic Diagram of the Equipment

Air Emission Control Equipment and Facilities

The main and auxiliary boiler would be specified to have low NO_x burners, which would have staged fuel and air mixing and over-fire air. These burners would reduce the flame temperature, which would result in lower NO_x concentrations in the boiler exhaust flue gas. Equipment for control of boiler emissions would include low-NO_x burners and a selective catalytic reduction (SCR) system, which in combination would provide very efficient NO_x emission control. The suggested operational constraints would specify an hourly limit for operation of auxiliary boilers and emergency generators to maintain overall compliance with emissions. The solids handling systems for coal, ash, and lime would be totally enclosed or would include spray dust suppression and wind break fencing to minimize fugitive emission possibilities.

Low-NO_x burner designs are currently available that generate less than 50 percent NO_x compared to burner designs available 10 to 15 years ago. This reduction is accomplished mainly with staged combustion and with over-fire air. Over-fire air provides the oxygen needed to complete the combustion in the staged concept. Staged combustion mixes air and fuel gradually so burner flame temperatures are lower resulting in lower NO_x.

The boiler flue gas (i.e., combustion exhaust) would enter the SCR unit for NO_x conversion to water and nitrogen. Next, the flue gas would flow through the air heater, which would improve the Generation Plant's plant efficiency by heating the incoming combustion air. SCR equipment would treat the boiler exit gas to reduce NO_x by approximately 80 percent. NO_x is converted by injecting ammonia upstream of a catalyst. In the presence of the catalyst (usually titanium oxide on a ceramic base), NO_x would react with ammonia and produce water and nitrogen. The catalyst would be located downstream of the boiler economizer and before the air heater where boiler exit gas temperature would be at an optimum (about 700°F). Installation of SCRs on coal plants is a relatively new development, but sufficient experience has been established to have a high confidence in proper operation of this equipment. This equipment is being employed to meet current air emission limits.

The Mine coal, which has a low sulfur content, in combination with a flue gas desulfurization (FGD) spray dryer and fabric filter baghouse, would provide the required SO_x control. SO₂ emissions would be controlled in the spray dryer absorber FGD system. A lime and water mist would be sprayed in the FGD vessel. This lime slurry consisting mainly of calcium oxide would be atomized in the spray dryer chamber. Calcium oxide would react with sulfur in the boiler exhaust gas and would produce calcium sulfur compounds and oxygen. The downstream fabric filter would collect the calcium sulfur compound dust.

The combination of low sulfur fuel and SO_x removal equipment would result in low SO_x emissions. The proposed spray dryer FGD system would minimize water consumption as compared to a wet limestone FGD system (approximately 305 million gallons per year for the proposed FGD system vs. approximately 420 million gallons per year for a wet FGD system.) The proposed FGD system also would generate less solid waste than a wet limestone FGD system (approximately 155,000 tons of waste per year for the proposed system vs. approximately 206,000 tons per year for a wet system). Water needed for this system would be obtained mainly from Generation Plant wastewater flows (Figure 2-5). Existing commercial sources are available to supply the needed lime, which would be delivered to the Generation Plant by railroad car.

The ash particulates generated during the combustion process would be removed by a fabric filter or 'baghouse' system. Most of the boiler fly ash particulate and calcium sulfate from the FGD system entrained in the boiler exhaust gas would be removed in the fabric filter baghouse. The air permit would limit air emissions.

Ash from the bottom of the boiler and baghouse would accumulate in separate hoppers and would be carried by truck to the disposal area or to the Mine. A fan(s) would aid in moving the boiler flue gas through the boiler and emission control equipment with subsequent discharge to the chimney.

Water Supply and Treatment Systems

Water for the Generation Plant systems would be supplied from four to six deep wells, each approximately 8,500 feet deep. The preliminary normal maximum Generation Plant operating water supply and usage rates are shown on the Generation Plant Water Balance Diagram, Figure 2-5. The information provided at this time is preliminary pending the completion of sufficient detailed design information and obtaining complete well water analysis.

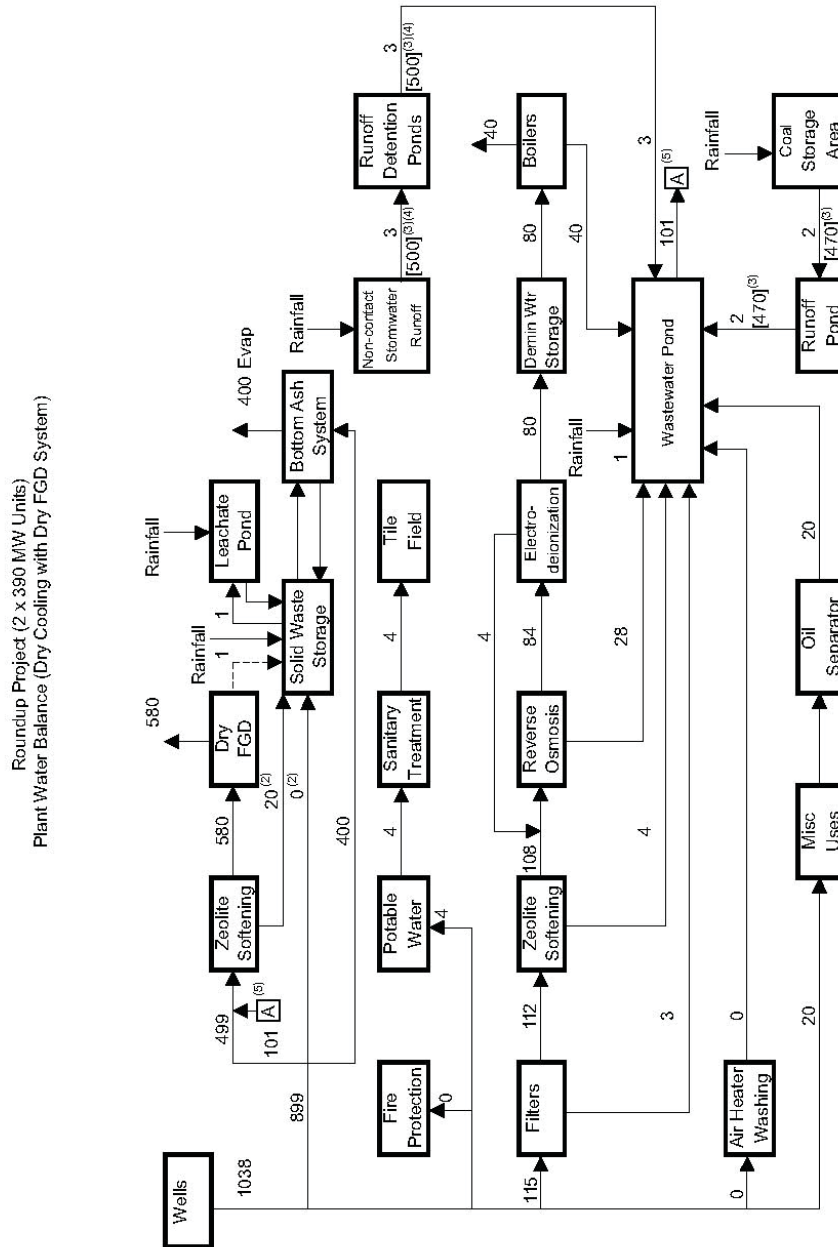

- Notes:
1. All flows are in gpm.
 2. Denotes water which is used for wetting of solid waste.
 3. Denotes maximum discharge flow due to 10 yr 24 hr storm.
 4. When the plant is not operating, uncontaminated stormwater collected in runoff ponds will be released to natural drainage courses.
 5. Water from the wastewater pond will be used as input prior to the zeolite softening process.

Revision 4

Figure 2-5 Generation Plant Water Balance Diagram

The flows shown in the water balance diagram are in gallons per minute (gpm) for both of the units operating at 100 percent output. Water from the wells would be stored in a vertical-walled tank that would be designed to provide the needed capacity for the Generation Plant based on the well water supply rate, a reasonable amount of storage for Generation Plant requirements, and for emergency fire protection supply.

Expected well-water usage for the two units operating at full load would average approximately 1,000 gpm. There also would be two vertical-wall tanks for demineralized water storage (one for each unit). The size of these tanks would be determined during the detailed design phase of the Generation Plant, but it is estimated that the well water tank would be roughly 250,000 gallons to 500,000 gallons and each of the two demineralized water tanks would be roughly 100,000 gallons to 250,000 gallons. Nearly all makeup of the water to the Generation Plant would be required in the spray dryer FGD system, replacing evaporative losses in the bottom ash handling and the supply of demineralized water to the boiler systems.

Pumps would supply the water from well water storage tanks to the main Generation Plant systems as described below:

1. A zeolite softener or other appropriate treatment would treat the dry FGD system water supply. This water would be used with lime for the slurry used in the spray dryer FGD system. All of this water would be evaporated and discharged to the atmosphere with the boiler flue gas from the chimney.
2. Water directly from the well water storage tank would supply the bottom ash system mainly the drag chain hopper. Most of this water would evaporate and would be carried with the boiler flue gas and discharges from the chimney. Overflow/blow down from the drag chain hopper and other wastewater would be used in the solid waste storage area for compacting and dust control.
3. Water for fire protection would be drawn directly from the untreated well water storage tank by dedicated fire pumps. There would be a jockey pump to supply small usage flows and to maintain water supply pressure. A large motor-driven pump and an emergency diesel-driven pump would be provided for major fire water supply.
4. Potable water would flow treated in a carbon filter and a chlorinator. Sanitary waste would be piped to a sanitary drain field.

The planned demineralized water treatment system would have filters, zeolite softening (or other pretreatment), reverse osmosis (RO), and electrodeionization that discharges to two large tanks (i.e., one for each unit), which would provide adequate reserve margin for the boilers to remain in operation when the water treating system is temporarily out of service, the units are being started, and/or there are leaks in one of the boilers or other equipment.

Water would be needed for the boilers. Treated water, filter backwash, zeolite softening regeneration, RO waste, and other waste flows would be collected in the wastewater pond for use in the dry FGD system.

Ultra-pure demineralized water would be required for the two main boilers. Normally, about half of the main boiler water usage would be water removed as blow down to the wastewater pond to

control the boiler water chemistry. Boiler water chemistry would be controlled by chemical feed and possibly an oxygen feed. The other half would be water that is converted to steam and vented as part of the required flows to the atmosphere from the feed water heaters for removal of non-condensable gases, or from the discharge of the condenser vacuum pumps. In addition, some demineralized water would be lost as leakage in pump seals, valve packings, and other miscellaneous places in the large amount of piping and equipment making up the Generation Plant steam and water systems.

This design would result in minimal well-water usage and no plant water discharges to the area surface water flows except for storm water when the plant would not be operating.

Air-Cooled Condenser

The proposed Generation Plant design includes an air-cooled condenser to minimize consumption of water. As shown in Figure 2-4, steam leaving the turbine would enter the air-cooled condenser and would be condensed by the airflow created by fans.

The air-cooled condenser design would be different from the condenser design used at most U.S. generation plants that use a wet cooling system. A wet cooling system condenses steam in a tube-and-shell heat exchanger (a condenser) with water. In these existing systems, cool water enters the condenser where it is warmed by the steam. The warm water is circulated from the condenser through a wet mechanical draft-cooling tower or to a river, lake, or ocean.

In the proposed design, the air-cooled condenser would provide a great reduction in plant water consumption (in the range of 95 percent less¹) because steam is passed through a continuous network of tubes in constant contact with air eliminating the need for water. This process would cause a somewhat higher steam turbine exhaust pressure that would lower plant efficiency slightly. However, the average ambient temperature in the Project Study Area is relatively cool (about 46°F), which would lessen the loss in efficiency relative to other possible Generation Plant locations with warmer ambient temperatures.

Storm Water and Wastewater Ponds

The storm water flow across undisturbed areas of the site would be maintained with storm water discharging to natural drainage courses. The storm water drainage system for the Generation Plant Study Area would be designed to discharge the peak 10-year, 24-hour runoff without backup of water in the sewer and ditch systems, and the 50-year, 24-hour runoff without flooding roads or equipment areas.

Storm water runoff from the Generation Plant Study Area would be collected in three storm water detention ponds. These ponds would detain the runoff to settle suspended solids and reduce downstream flooding. Each pond would be designed to contain storm water runoff from a 25-year, 24-hour storm event

One pond, which would be located northwest of the power block, would have a total capacity of 12.5 acre feet and would collect runoff from the power block, the construction laydown area, and

¹ Technical Development Document for Final Regulations Addressing Cooling Water Intake Structures for New Facilities, EPA-821-R-01-036.

the construction parking area. A second pond, located south of the power block, would have a total capacity of 3.3 acre feet and would collect runoff from the switchyard area. The third pond, located east of the Generation Plant, would have a total capacity of 21.5 acre feet and would collect coal pile runoff.

Each pond would be provided with both a gravity outlet system and a set of pumps. During Generation Plant operations, all water captured in the ponds would be pumped to the wastewater holding pond and used to wet fabric-filter waste (fly ash and FGD spent reactant). Runoff captured in the ponds when the Generation Plant would not be in operation or would not require water would be released to the natural drainage course at a controlled rate. All storm water discharges would meet the requirements of the facility's storm water Montana Pollutant Discharge Elimination System (MPDES) permit.

The wastewater holding pond would be designed to hold Generation Plant wastewater discharges and have a total capacity of 7.4 acre feet. The pond would hold discharges from the water treatment plant, boiler blow down, air heater wash water, and oil separator effluent. It also would be the collection point for water pumped out of the runoff detention ponds and the coal pile runoff sedimentation pond. Water collected in the wastewater holding pond would be pumped to the solid waste silos and used to wet fly ash and FGD waste before the ash and waste are disposed of. This pond would be designed for a 100-year, 24-hour storm event.

There is a leachate collection pond designed to store storm water from waste disposal cells 1 and 2. The collection pond would be designed for an appropriate storm event and is expected to be less than 10 acre-feet when designed.

Coal and Lime Storage

A conveyor belt would deliver coal from the Mine to the coal storage area. The coal storage area would consist of an active storage pile with a conveyor and an inactive storage pile for long-term storage of coal. Coal from the active storage pile would be used at night and on weekends when the Mine is not operating. Coal from the inactive storage pile would be used when the conveyor from the Mine is being serviced.

The coal storage area would be graded to drain to adjacent ditches. The ditches would discharge into the coal pile runoff sedimentation pond, which is designed to detain the 25-year, 24-hour runoff and to retain a three-year volume of sediment accumulating at the rate of 2,000 cubic feet of sediment per acre of area drained per year. The pond would have a pumping system (to pump storm water to the wastewater holding pond for reuse) and a gravity outlet (to be used when the pond is initially constructed.)

The coal storage area, the storm water ditches, and the sedimentation pond would all be lined with an impervious clay layer to protect groundwater. The pond would be cleaned about every three years. Coal fines from the cleaning operation would be returned to the active storage pile for use in the plant. All drainage discharges would meet the facility's storm water MPDES permit requirements.

Lime for the FGD system would be delivered by tank-type railroad cars or trucks and unloaded into silo(s). There would be no lime stored on the ground. Storm water runoff from the lime unloading area would drain into the coal storage area ditch and would be captured in the coal pile runoff sedimentation pond.

Solid Waste Disposal

Solid waste would consist primarily of bottom ash, fly ash, and spent reactant from the FGD system (i.e., lime). Bottom ash would consist of incombustible coal material that would settle to the bottom of the boiler, where it would be cooled and collected in a water-filled hopper. Fly ash would consist of incombustible coal material entrained in the flue gas exhaust. Fly ash and spent reactant from the FGD system (FGD waste) would be collected in the fabric filter baghouse.

Oxides of silicon, iron, aluminum, and calcium typically compose about 95 percent of the weight of fly ash and bottom ash. Fly ash and bottom ash may also contain trace quantities of other metals and a small amount of unburned carbon from the coal. FGD waste consists primarily of calcium sulfite and calcium sulfate, along with minor quantities of unreacted lime. Based on an analysis of the coal from the Mine, a preliminary list of the major constituents in the fly ash and bottom ash is provided in Table 2-1.

Table 2-1 Preliminary List of Major Constituents in the Fly Ash and Bottom Ash

Constituent	Concentration (percent)
Silica	49.63
Ferric oxide	8.1
Alumina	28.5
Titanic oxide	1.1
Calcium oxide	3.9
Magnesia	0.96
Sulfur trioxide	3.6
Potassium oxide	0.5
Sodium oxide	1.5
Phosphorous pentoxide	0.5
Undetermined trace constituents	1.8
Total	100.0

Over the life of the Project, most of the solid waste would be moved to the Mine for permanent disposal. This would require further permitting and licensing to comply with codes and standards present at the time. A solid waste disposal area would be provided in the Generation Plant Study Area to dispose of waste during periods when the Mine is not ready to accept waste or when access to the Mine is not possible for any reason.

The proposed disposal area would be a state-of-the-art landfill designed with two cells, each providing a five-year volume of storage. The disposal area would be lined for the protection of groundwater and provided with a leachate collection system to remove any water that leaches through the solid waste. The lining would be a single composite liner consisting of a 60-mil high-density polyethylene (HDPE) geomembrane over a 12-inch thick layer of low permeability

clay. The leachate collection system would consist of a 12-inch thick layer of coarse sand or coarse bottom ash placed on top of the geomembrane lining, an 8-inch diameter perforated HDPE collection pipe buried in a rock-filled collection trench and placed at the low point in the center of the cell, and a rock filled sump.

The collection pipe would discharge into the lined sump, which would contain a pump. All leachate and storm water entering a cell would be collected in the leachate collection system and pumped to the leachate collection pond. Water collected in the leachate collection pond would be pumped out and used to wet FGD waste or used in the disposal area irrigation system to control dust. Even when the Generation Plant is not operating, these flows could be used to irrigate the disposal area.

The leachate collection pond would be lined with two layers of 60-mil thick HDPE geomembrane, with a leak detection layer installed between the inner and outer geomembrane liners. Leakage through the inner liner would be monitored, and the pond would be repaired if leakage exceeds a preset action leak rate.

When a portion of the disposal area has been filled to the design elevation, a cap would be put in place to prevent infiltration of moisture into the solid waste disposal area. First, a 40-mil-thick low-density polyethylene (LDPE) geomembrane sheet would be placed over the waste material. Second, a geocomposite drainage layer consisting of a geotextile heat-welded to a geonet would be installed. Third, a minimum 30-inch layer of silty-clay soil material would be put into place. Finally, a 6-inch layer of topsoil capable of sustaining vegetation would be placed over the cap. Then the cap would be seeded with native vegetation.

Bottom ash would be loaded into trucks from a silo or hopper and transported to the disposal area, where it would be temporarily stored in a designated part of the Generation Plant Study Area. It would be recovered as needed for use in the 12-inch layer placed over the geomembrane liner for gathering leachate, or for other uses. Bottom ash is an impervious, glassy material.

Fly ash and FGD waste collected by the fabric filter also would be transported to the disposal area by truck. Before being loaded into trucks, this material would be mixed with about 20 percent water, producing a consistency similar to moist silt (e.g., an inert paste-like consistency). After reaching the disposal area, it would be distributed in layers and compacted. Water from the leachate collection pond would be sprinkled over the layers of fly ash/FGD waste to assist in compaction and dust control. The fly ash/FGD waste material would become somewhat hard and stable (i.e., similar to hard clay) as it dries.

Material Handling

Coal Handling System

A single conveyor belt about 4,000 feet long (1.2 acres) would deliver daily supplies of coal from the Mine to a small “active” coal pile. The active pile would be as large as 25,000 tons (i.e., about a three day’s supply). A radial/luffing stacker conveyor belt, which has the capability to swing horizontally and raise and lower, would be used to distribute the coal from the Mine over the active pile reclaim tunnel. The maximum pile size would be about 45 feet high and cover about 53,000 square feet over an arc length of 452 feet.

Normally, coal would be discharged onto the active pile and then flow through the below-grade reclaim hoppers to the plant silos. However, when necessary, large mobile equipment would be used to move coal to the reclaim tunnel openings and to the inactive pile. The inactive pile would provide an 11-day supply (i.e., approximately 92,500 tons) for the Generation Plant in case the Mine supply is interrupted. This pile would be approximately 40 feet high and cover an area of about 320 feet by 420 feet when full. Mobile equipment would be used to move coal from the inactive to the active pile.

The below-grade reclaim hoppers would discharge coal onto two conveyors, which would travel underground initially, then incline upward to the top of the crusher house. In this building, the conveyors would discharge to a surge hopper that would then supply coal to the ring granulators. The ring granulators, which would break the large coal pieces into the smaller sizes needed in the boiler pulverizers, would discharge the coal onto the two conveyors leading to the transfer house. From the transfer house, the coal would incline upward to the boiler building conveyor floor that would be above the coal storage silos. There would be two conveyor trippers to fill the boiler building coal storage silos. The silos, which would give about 12 hours of storage for full-load operation, would provide coal to the pulverizers.

Coal dust would be controlled along the entire conveyor and storage path. The operator would be able to control the conveyor height to minimize the vertical drop onto the active pile to reduce dust. A silt and wind fence would be constructed around the coal pile to reduce fugitive dust. Dust suppression sprays would be provided for these two piles. Compaction would be used on the inactive storage pile to provide additional dust control. Enclosed buildings and dust suppression spray systems would provide dust control at conveyor transfer points. Vacuum exhausters and fabric filters would be provided to ventilate the storage silos and to control dust.

Lime Handling

Lime would usually be delivered to the Generation Plant in bottom-dump railroad cars that discharge to a below-grade hopper. Lime would be conveyed from the hopper by a vacuum pneumatic and filter system to a 100-ton, 10-day storage silo. Lime from the storage silo would be conveyed by another pneumatic system to the lime day silo. The pneumatic systems would include air blowers, transfer hoppers, and piping. Lime from the day silo would be fed to slakers and mixed with water to the slurry consistency needed for the spray dryer FGD system. Fabric filters on each of the silos air discharges control dust.

Generally, the railroad cars would be brought in by a main-line locomotive and the empty railroad cars removed once per week in 10- to 15-car groups or about twice per month with more railroad cars. A small railroad car-moving tractor would be used to position the railroad cars for unloading normally on a several-cars-per-day basis during the daylight hours. This activity should be only a minor noise source relative to other overall Generation Plant and the Mine railroad traffic.

Ash Handling

Ash from coal combustion would occur as bottom ash and fly ash. Bottom ash would leave the boiler via a water quench/storage tank located below the boiler to a drag chain conveyor.

Conveyor belts would bring the bottom ash to hoppers for truck transport to the storage area. The bottom ash would be a hard, non-leaching, non-dusty aggregate that can be used for roads and other uses, or disposed in the landfill.

The fabric filter (i.e., baghouse) would collect both fly ash and the reacted lime from the FGD system spray dryer. The material would collect on the outside of the bags and then be dropped into the baghouse hoppers. This dry material would be conveyed by a pneumatic vacuum system from the hoppers to two large storage silos (i.e., one for each unit). Fabric filters on each of the transporting air silos would provide fugitive dust control. Dust from the silos would flow through a mixer where water would be added. Water would control dust during truck transport and to prepare the waste material for compaction in the disposal area for the initial period (i.e., 10 years) of Generation Plant operation. Disposal back to the Mine would take place when permitted and feasible.

Oil Storage

Oil Storage Tank Spill Containment Compound

The oil storage tank spill containment compound would be designed to comply with the requirements of National Fire Protection Association (NFPA) 30. The containment volume provided would be 110 percent of the volume of the tank capacity.

The spill containment compound would be constructed by building above-grade dikes around the tank. The dikes would have a maximum height of six feet, a minimum top width of three feet, and maximum side-slopes of two horizontal to one vertical. In compliance with 40 CFR 112, the interior of the spill containment compound would be lined with a minimum of 1 foot of clay to protect the groundwater from contamination due to an oil spill. The dikes would be protected from erosion with a minimum of six inches of crushed rock surfacing.

The clay in the interior of the compound would be covered with six inches of granular soil to protect the clay from desiccation or cracks due to freezing. The interior of the compound would be sloped away from the tank and toward a catch basin placed at the low point. Interior sloping would be away from the tank so that there cannot be any standing water adjacent to the tank during a rainfall. The drain line from the catch basin would be provided with a valve and connected to the oily water sewer that discharges through an oil separator. The valve normally would be closed and only opened by a trained operator when necessary to drain standing rainwater from the inside of the compound.

The oil truck and/or railroad tank car unloading area for filling the storage tank would have an oil spill containment compound designed to contain 100 percent of the contents of an oil truck plus freeboard. The containment compound would be concrete paved with mountable curbs. It would also have a gravity drain with a normally closed valve, which would also drain to the oil separator.

Other Areas with Potential Oil Contaminated Discharges

Equipment and other areas of the Generation Plant with the potential for oil contaminated discharges would be turbine area equipment and pumps, turbine area floor drains, turbine oil storage tanks, lube oil consoles, and the shops equipment and flood drains. These areas and

equipment would be drained via an oily water sewer piping system and discharged into an oil separator. Effluent from the oil separator would discharge into the wastewater holding pond.

All oil collected in oil separators would be removed from the site by a licensed contractor for proper disposal or would be burned in the main boilers.

Transmission Line

Each generating unit would be designed to generate nominally 390MW gross (350MW net) electrical capacity year round on a 24-hour per day basis. Electric power generated by the facility would be transmitted by three 28.2 mile-long 161kV transmission circuits that would extend from the Generation Plant to the Broadview Substation (Figure 2-6). The proposed structure configurations and designs are identified in Table 2-2. Two of the circuits would be supported on one set of wood-pole H-frame transmission structures (i.e., double-circuit line). The third circuit would be a single-circuit H-frame transmission line.

The Broadview Substation is connected to NorthWestern Energy’s transmission system and, under the current scenario, 500MW would flow west to the Garrison Substation and 200MW would flow south to the Yellowtail Substation into the PacifiCorp transmission system. Studies performed by both transmission entities have identified upgrades to support this scenario. These upgrades are being planned even without construction of the Project. The potential purchasers of electricity generated by the Project are power distributors (i.e., utilities) and industrial and commercial owners in Montana and the western United States.

The design, construction, operation, and maintenance of the Project would meet or exceed the requirements of the National Electrical Safety Code (NESC), U.S. Department of Labor, Occupational Safety and Health Standards, and the Project proponent’s requirements for safety and protection of landowners and their property.

Construction would be appropriately staged, given mitigation and other constraints, over a one-year period (i.e., 2005). The Project owners would complete the line survey, construction documents, environmental compliance and permitting issues to reflect the engineering design and committed mitigation based on a surveyed alignment.

Table 2-2 Electrical Design Characteristics of the Project

Feature	Description
Line Length	28.2 miles
Type of Structure	Wood pole H-frame
Structure Height	50 feet to 90 feet
Span Length	600 feet to 900 feet average ruling span
Number of Structures per Mile	7 to 9
Right-of-Way Width	300 feet
Structure Work Areas	Tangents: 100 feet x 75 feet; Deadends: 150 feet x 75 feet
Pulling/Tensioning Sites	10 feet to 100 feet x 300 feet

Feature	Description
Access Roads	14-foot travel way
Voltage	161,000 volts AC
Capacity	750MW to 800MW (three circuits)
Circuit Configuration	161kV: One double-circuit structure and one single-circuit structure; double-conductor per phase with horizontal configuration.
Conductor Size	161kV: 954 kcmil (1.196 in. diameter- Cardinal) ACSR, 1272 kcmil (1.345 in. diameter- Bittern) ACSR
Maximum Anticipated Electric Field at Edge of Right-of-Way	0.46 kV/m
Maximum Anticipated Magnetic Field at Edge of Right-of-Way	29 milli-Gauss (mG)
Ground Clearance of Conductor	21 feet minimum per NESC 212 ⁰ F
Pole Foundations	Direct Buried

Structures

The proposed structures for the 161kV transmission lines would be double-circuit wood pole H-frame and single-circuit wood pole H-frame structures. Spacing between structures would be approximately 500 feet to 900 feet. Three-pole, guyed dead-end structures would be used for angles greater than 45 degrees.

Typical pole heights for both the tangent and dead-end structures would range from 85 feet to 120 feet. The wood poles would be direct buried to a depth of approximately 20 feet, depending on terrain.

Work Areas

Work areas of 100 feet by 75 feet per mile of transmission line would be required at each pole site to facilitate the safe operation of equipment and construction operations. The three-pole dead end structures require larger work areas of 150 feet by 75 feet. Within these work areas, the permanent disturbance associated with each pole foundation would be approximately six feet in diameter.

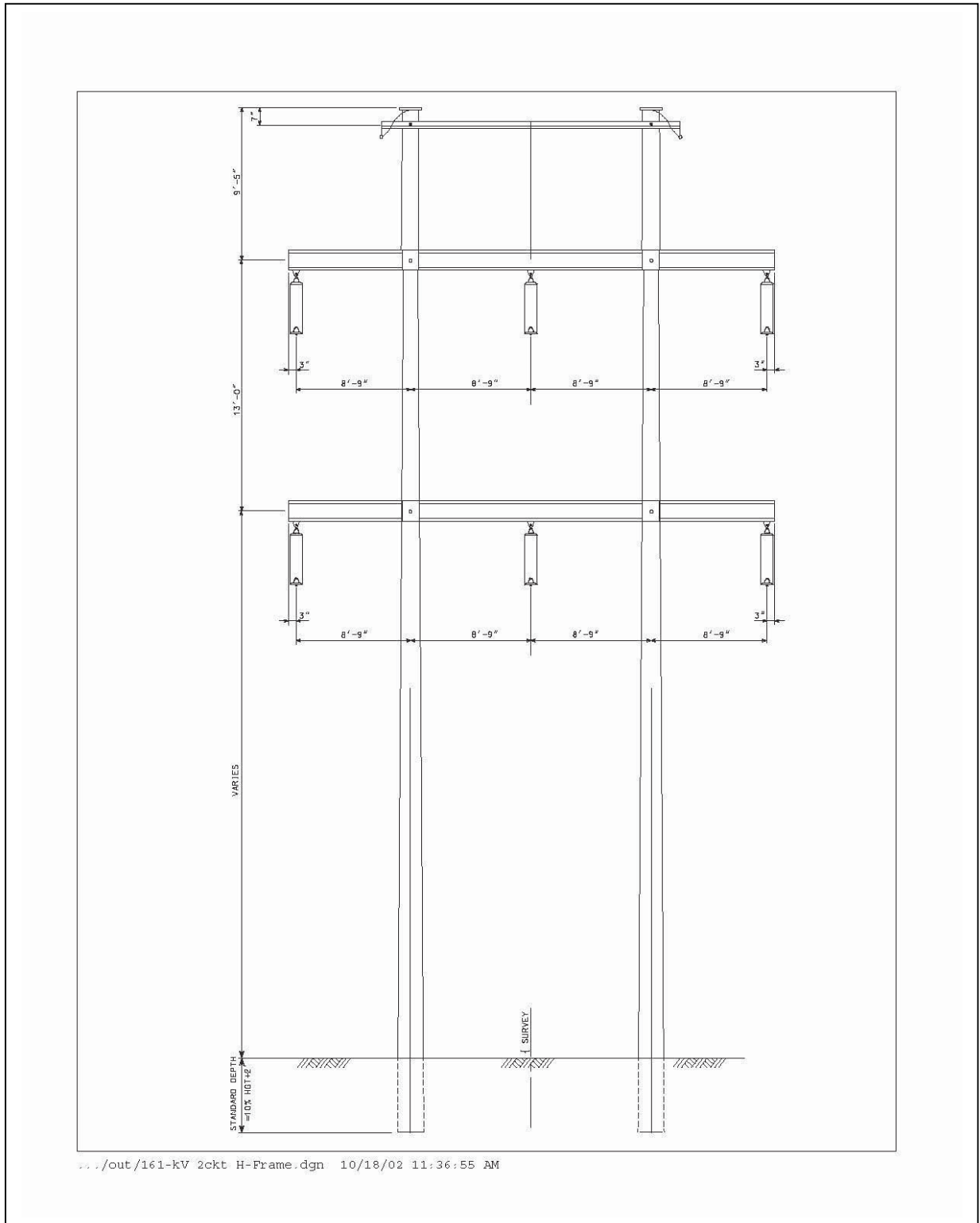

Figure 2-6 Transmission Line Design

Pulling and tensioning sites for stringing the conductor would result in an additional temporary disturbance of 100 feet by 300 feet per site. It is estimated that five pulling and tensioning sites would be required for the entire transmission line.

The work areas would be cleared of vegetation only to the extent necessary. After line construction, all work areas would be restored according to agreements with the landowners.

Access Roads

The Project would use existing roads and trails wherever feasible for access roads to minimize new disturbance when adverse conditions exist, such as the need to avoid sensitive resources, difficult topography, and/or landowner requirements. Access roads would be constructed with a 14-foot travel way.

Access roads would be used during construction to access work areas and during periodic maintenance of the completed transmission line throughout the life of the Project. After line construction, access roads would be restored according to agreements with the landowners.

Transformer and Switchyard

Each transformer would be an approximately 161kV-rated transformer at approximately 325mVA. Transformers would have a concrete spill containment compound designed to capture 100 percent of the oil contents of the transformer, 10-minutes of fire protection system spray water, and freeboard. Each spill containment compound would have a sump at one end, which would be connected by gravity sewer to an oil separator.

The oil separator would be designed with a flow capacity equal to the largest combination of flows directed to the separator and with an oil storage capacity large enough to contain the volume of oil equal to the contents of the largest transformer. Water from the separator would discharge into the wastewater holding pond. The switchyard would not contain any oil-bearing equipment. The switchyard would be graded for drainage to adjacent ditches, which would discharge into the storm water detention pond at the south side of the Generation Plant.

2.2.3 Additional Auxiliary Equipment

In addition to the main Generation Plant equipment and systems described in the preceding sections, a variety of other important systems, equipment, and Generation Plant facilities would be required for a modern coal-fired generation plant. The following list itemizes key auxiliary equipment:

- Compressors would supply air for valve and other power actuators and for maintenance use.
- Two auxiliary boilers (one per unit) would provide steam for heating the plant when the main boilers would not be operating and for starting one of the main boiler and turbine units.
- Vacuum pumps would remove air that leaks into the condenser and non-condensable gasses that would enter the condenser from the power cycle piping and equipment.

- Chemical feed equipment would be provided for the boiler water to maintain pH, oxygen content, and other parameters within the required ranges.
- Equipment lubricating oil systems would be provided on the main turbine-generator, boiler feed pumps and motors, coal pulverizers, and other equipment. Turbine oil lubricating oil storage tanks and filters would be provided for the turbine-generator for use during maintenance.
- Fire protection systems and pumps would be provided for the major lubricating oil reservoirs and piping on the steam turbine-generators, main transformers, coal handling, and other applicable areas. A diesel-engine-driven fire pump would be provided as a backup to the electric-motor-driven pumps.
- An equipment cooling system would be provided with a small air-cooled condenser or wet mechanical draft tower. This system would provide cooling water to the steam turbine-generator lubricating oil system, the generator hydrogen coolers, air compressor and boiler feed pump lubricating oil heat exchangers, and other Generation Plant equipment cooling requirements.
- Combustion air preheating system would use condensate or steam from the main power cycle or possibly warm water from the wells to heat glycol. The warm glycol would be used in finned tube heat exchangers to warm the air to the boilers in cold weather as required for proper boiler operation.
- Service water would be needed for washing the coal handling and other Generation Plant areas and for supplying other miscellaneous maintenance uses. Pumps supplying water from the well water tanks would provide service water.
- Hydrogen, nitrogen, and carbon dioxide gas storage tanks and piping would be provided for the boiler, turbine, and other equipment requirements.
- Foundations, piping, and supports are needed for all of the equipment.
- Cranes and other maintenance provisions would be needed for the equipment. The turbine-generator would require a large bridge crane.
- Fuel oil (No. 2) would be required for warming the main boilers and igniting the coal fuel during startup, and for the auxiliary boilers. A 400,000-gallon storage tank surrounded by earth berms with an oil separator and a truck and railroad car unloading area would be required.

Electrical Equipment

The major electrical equipment, which is typical for this type of generation plant, is listed below:

- Main power turbine generator step-up transformer.
- Station service transformer.
- Secondary unit transformer(s).
- Switchgear to control electrical power for large motors, electrical systems, and equipment.

- Motor control centers to control electrical power for large motors, electrical systems, and equipment.
- Battery equipment to provide power to the control system, backup-lubricating systems, and other high-priority equipment in case of a loss of electrical power supply to the Generation Plant.
- Two emergency diesel generators (one per unit) for backup to supply power to the battery equipment and other high-priority equipment in case of a loss of electrical power supply to the Generation Plant.

Instrumentation and Controls

The major instrumentation and controls system equipment, which is typical for this type of plant, is listed below:

- Distributed control system (DCS) for centralized operator control from the main control room
- Plant instrumentation to provide data to the DCS
- Local or separate programmable computer systems for water treatment, turbine-generator, coal handling, ash handling, and other equipment
- Continuous emissions monitoring system (CEMS) for monitoring emissions from the two chimneys

Communications

Off-site communication would take place primarily by telephone. However, a radio tower, microwave facility, or other such communication device, may be constructed for the Generation Plant. In addition to off-site communication using a telephone, Internet access and electronic mail would be available using computer network capabilities. Protective relay coordination between the facility and the interconnecting electrical transmission system would be available using fiber optic technology. On-site communication capabilities would include an intercom system, cellular phones, and/or two-way radios.

Storage Tanks

Following is a preliminary list of oil and chemical storage tanks that would be necessary for the Generation Plant.

Oil

- Turbine generator lubricating oil reservoir
- Turbine control system oil
- Generator lubricating and seal oil system
- Generator hydrogen cooling system
- Vacuum pump and motor lubricating oil system

- Air-cooled condenser fan bearings
- Clean and dirty turbine oil storage tanks and oil treatment equipment
- Main and other transformers
- Glycol combustion air preheating system
- Combustion air and boiler exhaust gas fans and motors
- Emergency diesel fuel oil storage day tank
- Emergency engine-driven fire pump fuel oil storage day tank and lubrication system
- Coal handling motors, gear boxes, lubricating systems, and reservoirs
- Boiler feed pump and motor lubricating oil system
- Main boiler and auxiliary boiler ignition oil relief valves
- Pulverizer lubrication equipment
- Air compressor and blower lubrication equipment
- Miscellaneous machine shop equipment
- Oil drain collection sumps, tanks, and separators
- Miscellaneous equipment, pumps, and systems

Chemicals:

- Fire protection foaming agents that may be used for the main transformers and other areas
- Boiler – turbine feed water chemical feed, including hydrazine and ammonia (in drums)
- Acid, anti-scalant, sodium bisulfate (in drums or totes) for the RO system, unless a demineralizer is used, which would result in the need for acid and caustic storage tanks
- Chlorine (chlorine cylinders or hypochloride) for potable water treatment
- Ammonia storage for the SCR
- Small quantities of miscellaneous Generation Plant and shop solvents and chemicals for Generation Plant maintenance and operations
- Small quantities of chemicals (corrosion inhibitors) for the equipment cooling water recirculation system and possibly the air conditioning chilled water system (if this type of HVAC is selected)
- Small quantities of air conditioning refrigerant gas

2.2.4 Construction

Project Schedule

Figure 2-7 shows the Project schedule for permitting, procurement of equipment, construction, and startup of the two units. The current plan is to proceed from the issue of major environmental permits to the commercial operation of Unit 1 in 42 months. Unit 2 would follow Unit 1 by about eight months. The overall Project sequence includes site selection and Project authorization, permitting, construction, and startup and testing. This is a typical schedule for this type of generation plant.

Site Selection and Authorization

Site information was gathered during the four-month period before submission of the air quality permit application, options were studied, and the preliminary site and plant layout was developed. This information provided the basis for the authorization to proceed with the Project and the permitting activities.

Permitting

This permitting schedule includes developing engineering information and submittal of the major permit applications.

Engineering and Procurement

Engineering and procurement work would begin with preparing the major plant equipment specifications for bids. Awards to the successful bidders would follow the evaluation of the bids, negotiations, and preparation of contracts. Information from the major contracts would be used to prepare the remainder of the specifications, which would be followed by the respective evaluations, negotiations, and contracts to the successful bidders. Equipment and system information for the plant would include several thousand drawings from equipment manufacturers and system suppliers.

Detailed design, including drawings and lists, for piping and instrument diagrams (P&IDs), general arrangements (GAs), foundations, building structural steel, electrical wiring, and other areas would be developed as information is received. Construction specifications would be issued for bids, and contracts would be awarded as necessary.

Construction Activities

Site clearing and access would begin shortly after the major permits are issued. The first construction work involves providing initial site access and clearing the building foundation areas of vegetation. Refer to Figure 2-7 for preliminary construction schedule.

Site work would begin by constructing access roads and parking areas for construction personnel. Heavy construction earthmoving equipment including bulldozers, scrapers, graders, trucks, and backhoes would be used to level the site area, by cut and fill, in preparation for constructing foundations, site roadways, and storm drainage. Suitable topsoil material would be retained for final site grading and reseeding. Gravel would be used for temporary roads,

Figure 2-7 Preliminary Roundup Project Schedule

equipment storage and laydown areas, and work areas. Precautions would be taken during these operations to contain erosion runoff and fugitive dust. In addition, connections and distribution systems for temporary construction communications and electrical power would be installed. One or more deep wells with pumps and underground piping would be installed for the construction water supply.

Each contractor would set up trailers and some small temporary buildings for their needs and for the duration of their work. The site construction Project management team would control each contractor's activities.

After completing most of the site preparation, the installation of the substructures (foundations) and structures would begin. This effort would include the power block substructure. Foundation construction would consist of foundation excavation, form erection, reinforcement installation, concrete placement, and foundation backfilling. These activities would require delivery of materials to the site and the use of an onsite concrete plant over about a 10-month period. During this stage, underground piping and electrical conduit would be installed between the building foundations. Major construction equipment used during this stage would consist of medium-sized mobile cranes, backhoes, dump trucks, concrete pumps, and concrete delivery trucks. A major portion of the railroad track would be installed at this time so that heavy material and equipment deliveries can be made by railroad car during the next phase.

Structural steel erection would begin when foundations are sufficiently complete. Large cranes would be provided to unload the steel members and raise them to their final location.

Boiler pressure parts would be shipped to the site over an eight-month period and installed in the building when the structural steel is sufficiently complete. A major construction activity would be raising the boiler drum into its required location near the top of the boiler room. Construction equipment used during this activity and the next few construction activities would consist of large mobile cranes, lowboy trucks, specialized hauling and rigging equipment, and material delivery trucks.

Other major equipment would begin arriving at the Project Study Area for erection during the next construction phase. Major equipment for this Project would consist of two steam turbines, main transformers, fans, condenser, SCR units, fabric filters, spray dryer FGD, air-cooled condenser, and other items. Usually, building siding installation begins at this point. The building would not be enclosed by siding and roofing until the major boiler and other equipment has been moved into place. However, enclosing the building as early as practical would help reduce weather delays.

Major equipment would be interconnected mechanically and electrically during the next stage. Mechanical activities include installing welded piping and supports with associated valves and accessories. Electrical activities would include installing cable trays and supports, and installing and terminating electrical and control cable. These activities would give rise to the peak construction manpower period for the Project. This peak construction manpower period would overlap the equipment erection stage and the startup and testing stage. Major construction equipment used during this stage would consist of medium-sized mobile cranes, flatbed trucks, welding machines, portable power generators and air compressors, and cable pulling equipment.

Startup and Testing

This stage is planned to begin approximately 12 months before commercial operation. It would consist of a systematic process of testing and initial operation of the many Generation Plant systems.

The following major events are included during this period:

- The power back-fed over the transmission lines to provide startup power
- The hydro testing and chemical cleaning of the boiler and various piping systems (chemical cleaning would be a closed process with waste residue removed from the site for proper treatment and disposal)
- Steam blow cleaning of the Generation Plant steam system piping
- Initial firing of the boilers for testing
- Generation Plant equipment testing
- Generation Plant performance testing for power output and environmental requirement conformation

Transmission Line Construction

Sequence of Activities

The construction of the transmission lines would follow the sequence of: 1) survey and stake centerline; 2) build access roads; 3) clear work areas as needed; 4) excavate holes, erect and install structures; 5) install fiber optic or traditional ground wire, conductors, and ground rods, and finally, 6) clean up and reclaim the site. The number of workers and types of equipment required to construct the transmission lines are shown in Table 2-3. Various phases of construction may occur at different locations throughout the construction process. This could require several crews operating at the same time at different locations. The preliminary construction schedule is shown in Table 2-3.

Table 2-3 161kV Transmission Line Construction – Estimated Personnel and Equipment

Activity	People	Quantity of Equipment	
Survey	3	1	Pickup truck
Road Construction	3	2	1 Bulldozers (D-8 Cat), 1 Excavator
		1	Motor graders
		1	Pickup trucks
		1	Water/gas trucks
Foundation Installation	8	1	Hole diggers
			Bulldozers
		2	Trucks

Activity	People	Quantity of Equipment	
		1	Concrete trucks
		2	Pickup trucks
		1	Carryalls
		1	Hydro crane
			Wagon drills
			Water trucks
Wood Pole and Steel Haul	4	1	Wood-pole and steel haul trucks
		1	Pickup trucks
		2	Yard and field cranes
		1	Fork lift
			Water trucks
Structure Assembly	6	1	Pickup trucks
Per crew		1	Carryalls
1 crews total		1	Cranes (rubber tired)
		1	Trucks (2 ton)
Structure Erection	5	1	Cranes (200 Ton)
Per crew		1	Trucks (2 ton)
1 crews total		2	Pickup trucks
		1	Carryall
Wire Installation	10	1	Wire reel trailers
		2	Diesel tractors
		2	Cranes (19-Ton, 30-Ton)
		1	Trucks (5 ton)
		2	Pickup trucks
		1	Splicing trucks
		1	3-drum pullers (1 medium, 1 heavy)
		1	Single drum puller (large)
		1	Double bull-wheel tensioner (heavy)
		1	Sagging equipment (D-8 Cat)
			Carryall
		1	Static wire reel trailer
			Water trucks
Wire Clean-Up	3	1	Trucks

Activity	People	Quantity of Equipment	
		1	Pickup trucks
		1	(D-6 Cat)
			Water trucks
Road Rehabilitation (right-of-way restoration)	2		Bulldozers
		1	Motor graders
		1	Pickup trucks
			Water trucks

**Maximum total personnel required considering all tasks
(actual personnel at any one time would be less)**

44

* including maintenance

Note: Depending on schedule requirements, multiple crews may be required.

Access Road Construction

The utility corridor has many existing trails and roads near the transmission line corridor. However, the existing road network would require some upgrading and spur road construction in order to allow access of construction equipment into structure sites. This may involve clearing vegetation and re-grading. Equipment to construct the access roads would include hand tools, bulldozers, graders, and crew-haul vehicles. The road construction work force is anticipated to number no more than 44 individuals at any one time (Table 2-3). Specific actions would be implemented to reduce construction impacts. Standard design techniques such as installing water bars and dips to control erosion would be included. In addition, measures would be taken to minimize impacts in specific locations and during certain periods of the year. Such conditions could arise during heavy rains or high winds.

Pole Installation

Wood-pole H-frame structures and associated hardware would be shipped to each structure work area by truck. Wood-pole H-frame structures would be assembled on the work area (Figure 2-8). Areas need to be large enough to accommodate laying down the entire length of the wood poles while cross arms and insulators are mounted to it. Cross arms would then be installed and rigged with insulator strings and stringing sheaves at each ground wire and conductor position, while the poles would be on the ground. The assembled wood-pole H-frame structures would then be hoisted into place by a large crane (Figure 2-8). Table 2-3 lists the equipment and personnel necessary for pole assembly and erection. Ground rods at each pole probably would be required. Deadend and turning structures would be vertical pole design with guy wires.

Temporary construction yards may be necessary and would be located on existing disturbed areas or other areas on private lands along the line route. The yards would serve as field offices, reporting locations for workers, parking space for vehicles and equipment or sites for temporarily

marshalling material. Personal vehicles would be parked in these work areas and not on the Project site

Conductor Installation

Once poles are in place, a pilot line would be pulled (strung) from pole to pole and threaded through the stringing sheaves on each pole. A larger diameter, stronger line would then be attached to the pilot line and strung. This is called the pulling line. This process is repeated until the ground wire and conductor is pulled through all sheaves (Figure 2-9).

Conductor splicing would be required at the end of a conductor spool or if a conductor is damaged during stringing. The work would occur on previously disturbed areas for the poles or pulling/tensioning sites.

The conductor would be strung using powered pulling equipment at one end and powered braking or tensioning equipment at the other end. For public protection during wire installation, guard structures would be erected over roadways, transmission-lines, structures, and other obstacles. Guard structures consist of H-frame poles placed on either side of an obstacle. These structures would prevent ground wire, conductor, or equipment from falling on an obstacle. Equipment for erecting guard structures includes augers, line trucks, pole trailers, and cranes. Guard structures may not be required for small roads. On such occasions, other safety measures such as barriers, flagmen, or other traffic control would be used. Table 2-3 lists the equipment and personnel necessary for pole assembly and erection.

Ground Rod Installation

As a part of standard construction practices, prior to wire installation, resistance along the route would be measured. If the resistance to remote earth for each transmission pole were greater than 25 ohms, counterpoise (grounds) would be installed to lower the resistance to 25 ohms or less. Counterpoise consists of a bare copper-clad or galvanized steel cable buried a minimum of 12 inches deep, extending from the pole.

Operation of Transmission Line

Operational Characteristics

The nominal voltage for the Project's Transmission System would be 161kV alternating current (AC). There could be minor variations of up to five percent above the nominal level, depending upon load flow.

Safety

Safety is a primary concern in the design of this 161kV Transmission System. An AC transmission line would be protected with power circuit breakers and related line relay protection equipment. If conductor failure were to occur, power would be automatically removed from the line. Lightning protection would be provided by overhead ground wires along the line. Electrical equipment and fencing at the switchyards would be grounded

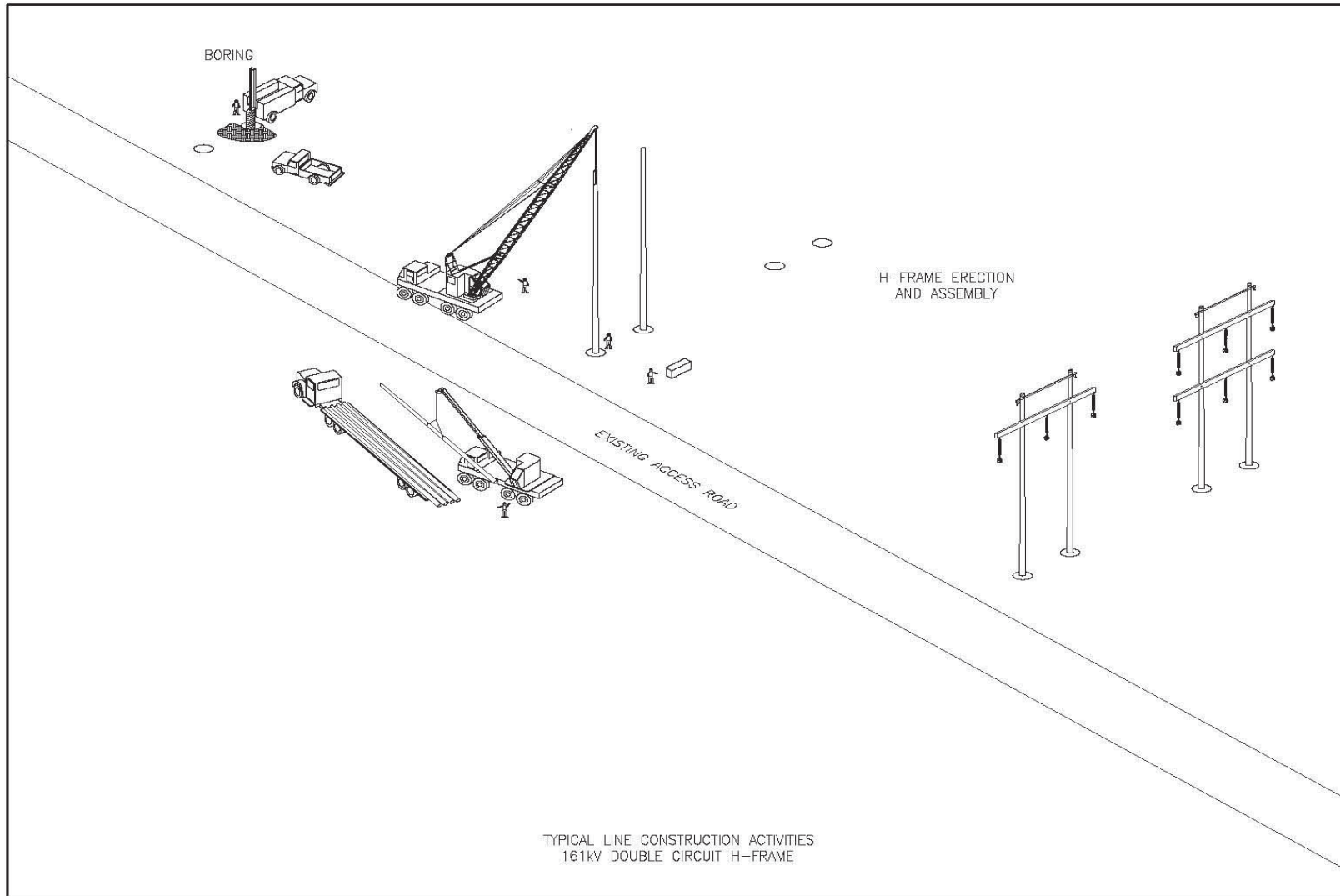

Figure 2-8 H-Frame Transmission Line Structure Assembly

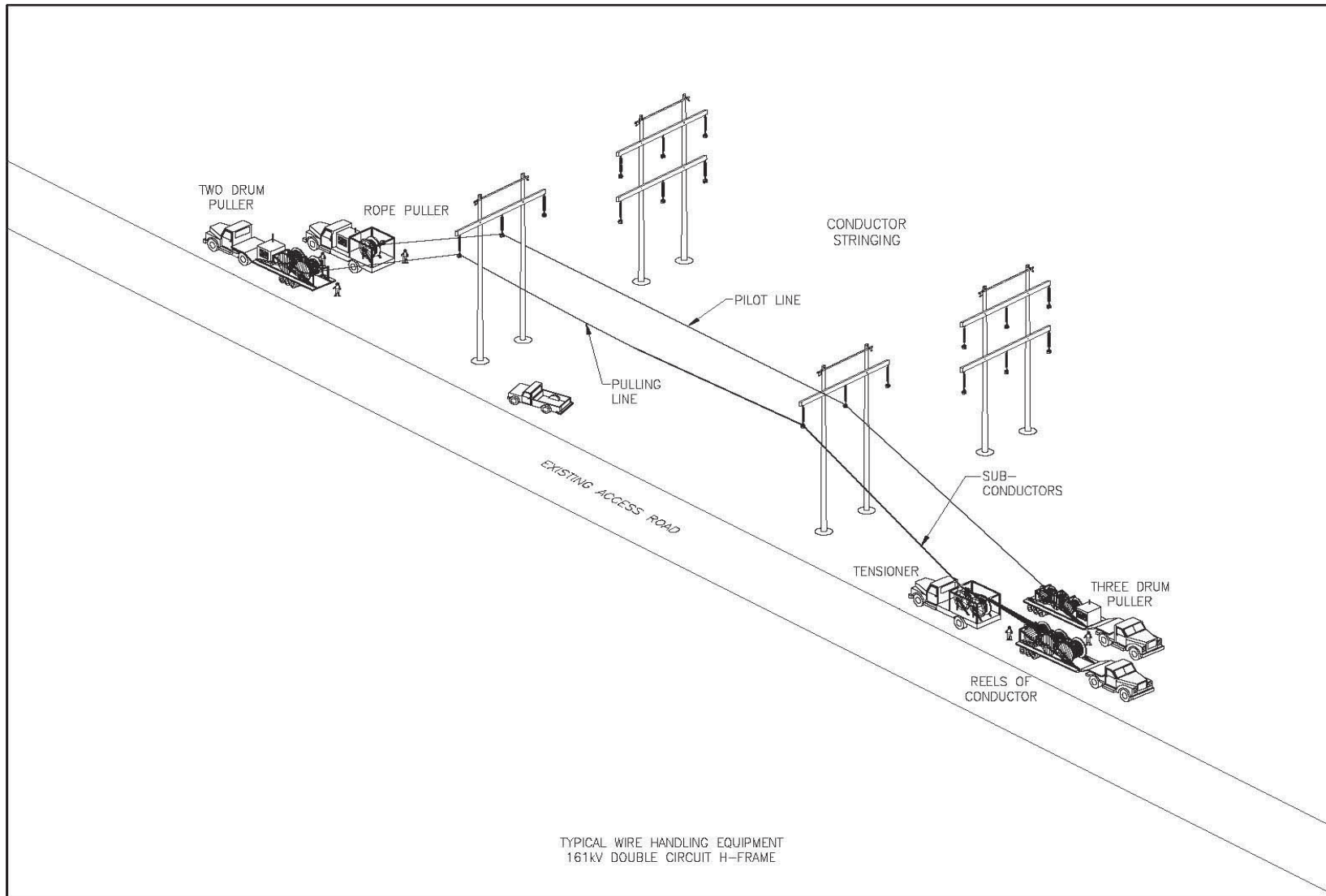

Figure 2-9 Transmission Line Wire Pulling

Maintenance of the Transmission Line

The 161kV transmission lines would be inspected on a regular basis by both ground and air patrols. Maintenance would be performed as needed. When access would be required for non-emergency maintenance and repairs, the maintenance crews would adhere to the same precautions that would have been taken during the original construction.

Emergency maintenance would involve prompt movement of repair crews to repair or replace any damage. Crews would be instructed to protect crops, plants, wildlife, and other resources of significance. Restoration procedures following completion of repair work would be similar to those prescribed for normal construction. The comfort and safety of local residents would be a primary concern during construction and maintenance activities. Noise, dust, and the danger presented by maintenance vehicle traffic would be limited to the extent possible.

2.2.5 Mitigation Measures

A goal of the Project is to minimize effects to the environment during construction and operation. In addition to the measures discussed throughout Section 2.2, above, the following measures or techniques would be employed, as necessary and appropriate, to avoid or minimize impacts as part of the Project design.

The following mitigation measures cannot be required by DEQ without a request from the Project proponent that they be placed in a permit (75-1-201(5)(b), MCA). The Project proponent may request that any or all of the mitigation measures that pertain to expected impacts from their proposed activities be placed in the permits. In those instances when the proponent chooses not to include a mitigation measure in a state permit, the Project proponent may decide to perform the proposed mitigation voluntarily.

Construction and Maintenance Access

- CM-1 All construction vehicle movement outside the 300 foot-wide easement would normally be restricted to predesignated access as negotiated with the landowner, contractor-acquired access, or public roads. Construction activities for the transmission lines would be restricted to and confined within the predefined limits.
- CM-2 Roads would be built at right angles to the streams and drainages to the extent practicable.
- CM-3 Culverts or rock crossings would be installed where needed.
- CM-4 Existing roads would be utilized for construction where feasible.
- CM-5 No paint or permanent discoloring agents would be applied to rocks or vegetation to indicate limits of survey or construction activity.
- CM-6 Prior to construction, all supervisory construction personnel would be instructed on the protection of important cultural, paleontological, and ecological resources.

Air Quality

- AQ-1 Suggested design and operation mitigation measures include

- Coal cleaning and/or coal preparation
- NOx control
- Carbon sequestration, such as planting trees

Earth Resources

ER-1 A Landfill Management Plan would be developed to address potential environmental impacts from proposed waste disposal.

Water Resources

WTR-1 Alternate water supplies may be necessary for a small number of wells that are proven to be directly influenced by reduction of recharge due to the plant construction.

WTR-2 Installation of groundwater monitoring wells near the landfill area would serve to identify groundwater impacts from leachate releases. Groundwater monitoring wells should be installed prior to startup of landfill operation in order to establish baseline conditions. A minimum of three groundwater-monitoring wells would be required to characterize groundwater quality and flow direction beneath the landfill area.

Waste and Cleanup

WC-1 No equipment would be refueled or greased within 100 feet of a wetland or perennial stream. In addition, fuels, oils, lubricants, herbicides, or other potentially hazardous materials would not be stored within 300 feet of a wetland or perennial stream.

WC-2 A spill prevention plan would be developed that addresses containment and cleanup of spills affecting surface waters.

Botanical Resources and Wetlands

BW-1 Existing vegetation would only be cleared from areas scheduled for immediate construction work and only for the width needed for active construction activities.

BW-2 All reseeding mixtures used for reclamation would be certified weed-free.

BW-3 Effective soil erosion control and reseeding of disturbed areas not required for permanent access for the transmission line would be implemented to encourage revegetation.

BW-4 Transmission line structures would be located to span streams and drainages.

Wildlife Resources

WR-1 Harassment of wildlife would not be permitted at any time during Project construction activities.

WR-2 Construction timing would be altered in specific identified areas where sharp-tailed and sage grouse leks are identified.

- WR-3 Install raptor diverters on transmission structures in specific identified locations to discourage raptor roosting and potential raptor predation on certain terrestrial species (e.g., sage grouse on strutting grounds).

Cultural Resources

- CR-1 Each cultural resource potentially affected by the proposed action should be more completely documented and evaluated so that a formal determination of National Register eligibility can be made by the State Historical Preservation Office (SHPO).
- CR-2 An assessment of effects should be performed in accordance with Section 106 of the NHPA if a cultural resource is determined eligible to the National Register.
- CR-3 Adverse effects should be avoided by project redesign, if feasible, if a considerable cultural resource would be affected by ground disturbance.
- CR-4 Appropriate mitigations measures, including data recovery, should be implemented following consultation with the Montana SHPO, Native American tribes, and other interested parties if a National Register-eligible resource cannot be avoided through project redesign.

Visual Resources

- VR-1 No paint or permanent discoloring agents would be applied to rocks or vegetation to indicate limits of survey or construction activity.
- VR-2 Wood poles or dulled metal surfaces would be used for the transmission line to reduce visual contrast.
- VR-3 In construction areas where ground disturbance would be substantial or where recontouring would be required, surface restoration would occur as required by the landowner. The method of restoration could consist of loosening the soil surface, replacing rocks or plants removed during transmission line construction, reseeding, mulching, installing cross drains for erosion control, placing water bars in the road, and filling unnecessary ditches.
- VR-4 To minimize ground disturbance over the transmission line route and/or reduce scarring (visual contrast) of the landscape, the alignment of any new access roads or cross-country route would follow the landform contours in designated areas where practicable.
- VR-5 Non-specular conductors would be used to reduce visual contrast.
- VR-6 Where possible the edges of clearings in forested lands or tree groves would be feathered to avoid abrupt, straight lines.
- VR-7 Baffled strobe lights would be installed on Project chimneys to direct light upward rather than outward if strobe lighting is determined to be required by the Federal Aviation Administration (FAA).

Noise

- N-1 Careful evaluation of specifications and design selection of typical low-noise design options, equipment specifications, building and wall designs, and enclosure constructions would be made during the design process to ensure that the Generation Plant noise is not excessive.
- N-2 The Proponent would implement noise control measures at the Generation Plant, such as silencers for decreasing noise generated during boiler steam blowout for plant start-up and maintenance.
- N-3 If measured noise levels exceed L_{dn} 55 dBA at the sensitive receptors, then additional noise control measures would be installed, as necessary, to avoid adverse impacts on the sensitive receptors.

Land Use and Safety

- LS-1 Existing improvements, such as fences and gates, would be repaired or replaced to their condition prior to disturbance or as agreed to with the landowner, if they are damaged or destroyed by transmission line construction activities.
- LS-2 Temporary gates would be installed only with the permission of the landowner and would be restored to original condition prior to disturbance following transmission line construction.
- LS-3 All existing roads would be left in a condition equal to or better than their condition prior to the construction of the transmission line.
- LS-4 All new access not required for operations and maintenance of the transmission line would be closed using the most effective and least environmentally damaging methods appropriate to that area with concurrence of the landowner.
- LS-5 The Project would comply with any FAA requirements regarding public safety.
- LS-6 Warning signs and flag-persons would be used at all roadway crossings during transmission line construction for all state, federal, county, and local roads and highways.
- LS-7 To prevent problems with livestock during the transmission line construction, all fences and gates would remain closed at all times throughout construction unless specified otherwise by the agency manager or landowner.
- LS-8 The proponent and the construction contractors would coordinate activities with property owners to ensure continued access across the transmission line right-of-way for the use of property by the property owner.
- LS-9 Harassment of livestock would not be permitted at any time during Project construction activities.

2.3 Alternatives Considered and Eliminated

The Project proponent identified numerous alternatives to the Project. Alternative designs, locations, pollution control devices, water supplies, fuels, equipment, and facilities were considered. The alternatives described in this section were eliminated from further consideration because they did not meet the stated purpose and need for the Proposed Action or were found to be unreasonable for detailed analysis based on the selection criteria described below. A summary of the alternatives considered and eliminated is provided in Table 2-4.

2.3.1 Alternative Fuel Sources

Several alternative fuel sources, including lower sulfur coal, synthetics, coal bed methane, gases, and fuel cells, were considered. Lower sulfur coals, ranging from hard to soft coal, from outside locations were ruled out due to the mine mouth location and the abundance of fuel at the plant site. Economics of the facility rely upon an abundant supply of coal in the immediate vicinity as a mine-mouth project. No expected changes in regulations, except new emissions would have to be calculated and modeled for any alternative fuel source. This alternative is eliminated and deemed not economically feasible.

Synthetic fuels such as synthetic-gas, coal gas, ethanol, and oil emulsion also were considered for possible import or on-site storage. These were eliminated from consideration due to the lack of transportation methods, dependability problems, and future availability of sufficient quantities. Methane fuel from coal bed production also was eliminated from consideration for those same reasons.

Liquefied natural gas and propane or butane fuels were considered but dismissed as impractical and too expensive because they require extensive storage facilities and would cause a problem with transportation logistics. This alternative was eliminated and not considered economically feasible.

Fuel cells were considered as a potential source but eliminated due to cost and substantial water and hydrogen or gas requirements.

2.3.2 Alternative Water Supplies

Alternative water supplies from both surface water and groundwater sources were evaluated and eliminated. Consideration also was given to using recycled water. Groundwater sources such as shallow aquifers would not supply a sufficient amount of water to operate the plant. In addition, withdrawals for the plant would affect local well water users. The amount of drawdown and eventual lowering of the shallow water table would be a disadvantage to the local populace.

Surface supplies considered included the two nearest rivers – Yellowstone and Musselshell rivers. The Yellowstone River is more than 30 miles away from the proposed Project site at its nearest point. The legal difficulties, environmental impacts, and costs associated with securing water rights, obtaining a right-of-way for a water pipeline, constructing the pipeline, and continuously pumping water more than 30 miles make this alternative economically impractical and unreasonable.

Table 2-4 Summary of Alternatives Considered but Eliminated

The Musselshell River, located 13 miles from the Project site, could not supply the necessary amount of water to operate the plant based on past historical stream gauging data.

All alternatives other than deep water wells are not considered reliable and of sufficient consistency to meet the needs of the Project and were eliminated from further consideration.

2.3.3 Alternative Cooling Systems

Methods to reduce water consumption were considered in the design process when choosing the cooling systems to be used at the Generation Plant. The wet mechanical draft wet cooling tower design circulates cooling water (by pumps) to the condenser (a shell-and-tube heat exchanger) to condense the steam leaving the turbine. Warm water from the condenser flows to the cooling tower and is distributed over heat exchange surface (usually a lattice). Fans draw air over or through the water stream, cooling the water. The water would fall into a collection basin and then would be pumped back to the cooling tower.

A typical wet mechanical draft cooling tower for each of the two units would require about 3,500 gallons per minute (gpm) of makeup water for evaporation, drift, and blowdown during full-load, warm weather operation. This amount of water consumption is significantly beyond the planned usage. Wet cooling towers are technically feasible and less expensive than dry cooling systems, however, wet cooling designs increase water usage. In addition to wet systems, a once-through cooling design was considered and eliminated because there is no large supply of water in the area.

Optimizing the amount of necessary makeup water required (i.e., water conservation) is important. The facility design chosen for the Proposed Action uses much less water for producing electricity than other available technologies.

2.3.4 Alternative Combustion Systems

The four combustion systems considered include the following: stoker, integrated gasification combine cycle (IGCC), boilers, and gas turbines / combined cycle facilities. These systems are described below.

Because of the size of available stoker boilers, a stoker is not a practical design for the Project. Current stoker designs are limited to 50 to 75 MW equivalent capacities, which would mean the installation of at least five or six boilers. The large number of boilers would add significant cost and complexity of design. In addition, stoker boilers have usually been designed for lower pressure and temperature steam, which results in a lower overall plant efficiency that would increase electrical costs and produce relatively more air pollution and solid waste. Cost per megawatt output would be expected to increase slightly.

There would be no expected changes in regulations except that new emission rates would have to be calculated and modeled. Air, solids, water, and waste requirements would be completely different. This alternative was eliminated because it would not substantially accomplish the proponent's goals.

IGCC is a developing technology with limited operating experience. IGCC and circulating fluidized bed (CFB) boilers are alternative power plant technologies, and they could not be used without redefining the Project. Current IGCC systems, such as Pinon Pine, have not

demonstrated reasonable availability (due to component failures) nor have their emission levels (as reported by the EPA Emissions Scorecard) been any lower than conventional plants. Fluidized bed boilers cannot achieve the same degree of sulfur dioxide capture that would be accomplished by a dry scrubbing system. If either technology were used, the entire Generation Plant design, including turbine-generators and material handling equipment, would have to change. These technologies would require a redefinition of the plant emission source, and they are not within the scope of a best available control technology (BACT) determination. In summary, normal BACT determinations are based on control technologies not on alternative source technologies (e.g., alternative boilers). Redefining the facility is not in the scope of a normal BACT analysis.

CFB boilers are typically used to combust low-grade fuels that may be difficult to pulverize and fuels having a high sulfur content, high ash content, or variable combustion characteristics. The inherent features of CFB technology make it advantageous for use with low-quality fuels. For high-ash coals, the CFB offers an advantage in fuel preparation over pulverized coal systems. For use with high-quality fuels, such as the coal that the Project would use, pulverized coal firing provides a wider flexibility in operation and higher thermal efficiency. A CFB boiler is a well-established technology and could be designed to achieve an SO₂ emission rate (in lbs/mmBtu) somewhat lower than the emission rate proposed by the proponent. However, the lower emission rate would be largely offset by the additional fuel and fuel preparation for a CFB boiler in order to produce the same net power output.

CFB units require significantly more auxiliary power for proper operation than pulverized coal units require. This increase reduces the efficiency of the CFB boiler. In other words, when compared to pulverized coal boiler, more fuel must be combusted in a CFB boiler to generate the same net power output. The additional fuel is required because CFB boilers require larger air and flue gas fans that consume a higher percentage of the plant gross power output. This process requires larger amounts of coal firing and steam flow and a larger steam turbine and air-cooled condenser to achieve the same net plant power output. CFB boilers are not commercially available in a 390 MW size. Therefore, to provide the same power generated by the two 390 MW pulverized coal-fired boilers; it would be necessary to use three smaller CFB boilers and three turbine-generators.

Constructing three generating units instead of two would significantly increase costs. Based on recent actual CFB project experience and best engineering judgment, the cost of three CFB units would increase the cost of the Project by approximately \$78 million to \$156 million. Therefore, based on the increase capital costs for three CFB boilers and increased fuel costs, the SO₂ emission rate in lbs/Kw-hr would not provide a significant advantage. In addition, the construction of three units would extend the overall construction schedule of the Project by at least one year. Therefore, based on increased capital costs, extended construction schedule, and lack of significant environmental advantages, this alternative was eliminated because it would not substantially accomplish the proponent's goals.

Gas turbines used separately (simple cycle applications) are expensive to operate because of the combination of their lower efficiency and higher costs for natural gas fuel. For these reasons, simple cycle gas turbine applications are used primarily for power supply (periods when there is a high demand for electricity.)

This design mixes a gas turbine cycle with a steam turbine cycle to combine in the production of energy. If the steam is used in an industrial application, the result is a “co-generation” combined cycle plant where the low-pressure steam is used for some process function. Neither type of gas turbine plant is as advantageous as pulverized coal for providing the base load power supply planned for the Project, nor would they utilize the high quality coal supply by conveyor from the Mine to the plant (mine mouth plant concept). The IGCC and CFB units were considered for general project planning (not as emission control technologies) and they were found not to be economically suitable for the project. This alternative was eliminated because it would not substantially accomplish the proponent’s goals.

2.3.5 Alternative Solid Waste Systems

The principle solid waste streams in coal-fired utility boilers consist of bottom ash, fly ash, and pyrites. In addition to the coal waste streams, there is a calcium-based FGD waste residue, which depends upon the FGD technology selected. The alternative solid waste systems considered and eliminated are described below.

Dewatering, stabilization, and fixation technologies for FGD waste have been eliminated from consideration and further analysis due to the use of a dry scrubbing system.

Two types of systems can be used to transport bottom ash:

- A “wet piping system” where water at high pressure flowing through a nozzle pushes the ash out of the hopper.
- A “drag chain system” where ash is carried from the hopper to a conveyor system.

The “wet piping system” was eliminated from consideration because this system requires more makeup water than the drag chain system.

Placing the solid wastes (ash and FGD waste) within the Mine waste rock depository was considered. This would require the waste to be transported over three miles to the Mine waste rock site, and placed as an engineered lens within the waste rock generated from the mining activity. This alternative was eliminated because of the following reasons:

- Requires a longer haul route
- Increases the size of the waste rock dump
- Requires coordination with the mine operations to stage the dump development
- Exposes groundwater to potential effects from leaching through the waste rock in the unlined dump
- Creates stability issues within the waste rock dump

Transportation to an off-site commercial landfill would require permitting and construction of an on-site transfer, storage and disposal facility (TSDF), transport of the waste to a remote landfill, and payment to a third-party concessionaire. This alternative was considered and eliminated because of the lack of a nearby suitable landfill, and prohibitive transportation and tipping fee costs.

2.3.6 Alternative Wastewater Discharge Systems

Alternative wastewater disposal methods considered included direct discharge to drainage ditches, subsurface injection, evaporative ponds, land application, and piping offsite to the mine. Temporary piping of effluent discharge to a dry gulch and spray discharge of wastewater on croplands in the immediate area were considered and eliminated due to the availability of alternatives that allow reuse of wastewater at the plant site.

Discharge of wastewater to the environment, either to surface water bodies or to groundwater would result in increased water consumption and a greater potential for impacts to water resources. The water balance presented in the Project indicates that there would be zero discharge of wastewater during normal plant operation.

2.3.7 Alternative Emissions Control Systems—Main Boiler

The proposed pollution controls for reducing criteria pollutants would provide reduction in hazardous air pollutant (HAP) emissions as well. Activated carbon injection primarily for mercury control was considered as an additional HAP control technology. However, the EPA is currently studying the effectiveness of activated carbon on different coal and boiler types. Because this technology has not been proven yet for a similar facility, it was not chosen for application to the Project. Other combination of control technologies were considered but rejected as not providing additional HAP control benefits without reducing criteria pollutant efficiency.

The wet flue gas scrubber process (wet FGD) requires dewatering before disposal. Wet FGD systems use significantly more water and have significantly higher capital costs than dry FGD systems. Wet FGD was considered and eliminated based on increased water consumption, increased wastewater production, increased solid waste generation, increased particulate emissions, and increased sulfuric acid mist emissions. The permit submittal from Roundup to the DEQ states that material handling fugitive emissions will increase due to the techniques of limestone handling with a wet FGD as compared to lime handling with a dry FGD. It goes on to state that approximately two tons per hour of limestone would need to be handled as compared to lime. Particulate emissions would increase if a wet ESP is installed rather than a baghouse (from PM₁₀ BACT). A dry FGD would reduce sulfuric acid mist emissions by 1,045 tpy when compared to a wet FGD without a wet ESP. A wet FGD combined with a wet ESP would decrease sulfuric acid emissions by 84 tpy when compared to a dry FGD. Visibility impacts on Class I areas would improve only slightly with a wet FGD combined with a wet ESP when compared to a dry FGD, and visibility impacts improve with a dry FGD when compared to a wet FGD without a wet ESP.

A circulating desulfurization system (CDS) or circulating dry scrubber was considered. The initial BACT demonstration included an evaluation of CDS technology. CDS was rejected as BACT because it did not offer significant benefits, had not been demonstrated on a large pulverized coal-fired boiler, and had anticipated difficulties associated with adapting the technology to a large pulverized coal-fired boiler. In DEQ's February 27, 2002, request for additional information, the agency requested a more detailed evaluation of CDS. In response, the proponent submitted additional technical information to DEQ supporting the rejection of CDS as BACT. Among other impacts, using circulating dry scrubbers for SO₂ control could necessitate

using electrostatic precipitators for PM10 control, and that could require increasing the PM10 emission rate above the limit proposed.

Post combustion controls, such as thermal oxidation and catalytic oxidation, were rejected based on technical infeasibility. Sulfur compounds and particulate matter can foul both systems so that placement of the units would have to be after the baghouse; therefore, reheating the exhaust stream to 600°F and 1,500°F for the catalytic oxidizer and thermal oxidizer, respectively, would have to occur. No cost analysis was provided but \$/MW output would increase with control equipment costs and operation and maintenance costs (i.e., reheating of the exhaust gas). New emission rates would have to be calculated and modeled.

The need for additional pollution control facilities such as wet precipitators and scrubbers to control pollution were considered and eliminated. The additional water supplies and wastewater that would be required to transport or dispose of collected materials was deemed an unnecessary technological resource and would have created the additional problem of disposing of solid waste. Wet precipitators and scrubbers are used to control SO_x and fine particulates. Since these pollutants are expected to be controlled from the Project, these types of facilities would not be necessary.

Flue Gas Recirculation (FGR) with Selective Non-Catalytic Reduction (SNCR) were considered and eliminated. SNCR units typically are not installed on pulverized coal (PC) coal-fired units but rather on natural gas-fired units. SNCR is technically feasible but typically not installed on PC coal-fired units and does not control NO_x (60 percent as compared to 80 percent) as well as selective catalytic reduction (SCR) for this type of facility.

2.3.8 Alternative Generation Sites

The proposed site is the only site that was considered for the Project. Alternative locations for the facility as well as number of units were viewed as not suitable to the purpose and need of the Project. Alternative sites would not be close enough to major transportation routes (i.e., both interstate highways and railroad systems) to allow for the transport and receipt of materials. The basic concept of the Project is a mine-mouth, twin-unit, coal-fired Generation Plant. There is no consideration given to reduce the number of plants from two units to one unit. A one unit plant was considered but eliminated because of economic and plant reliability option. The economics of the Project are based on the availability of an abundant supply of low-sulfur, high-quality coal in the immediate vicinity. Other locations that were adjacent to the Mine were considered and evaluated. These other sites did not have access to roads, were not as close to the Mine, the topography and drainage were not as good, and they were unavailable for purchase.

As discussed in Section 2.3.1, the mine-mouth concept minimizes both environmental impacts and costs associated with fuel transportation. The proposed site location is the best available option from both an environmental and an economic standpoint.

2.4 Alternatives to the Proposed Action

2.4.1 Landfill Alternative

Over the life of the Project, construction and operation of additional landfill cells on the Generation Plant site is proposed as an alternative to moving most of the solid waste to the Mine for disposal. Disposing of waste in the Mine would require further permitting and licensing to comply with codes and standards now in effect. A solid waste disposal area is indicated on the Generation Plant site layout to provide storage requirements to dispose of waste for the life of the plant (Figure 2-10).

The landfill would be a state-of-the-art facility designed with two cells, providing a 60-acre volume of storage. The disposal area would be lined for the protection of groundwater and provided with a leachate collection system not to exceed 10 acres to remove leachate and storm water that collects on top of the lining. The lining would be a single composite liner consisting of a 60-mil HDPE geomembrane over a 12-inch thick layer of low permeability clay.

The leachate collection system would consist of a 12-inch thick layer of coarse sand or coarse bottom ash placed on top of the geomembrane lining, an eight-inch diameter perforated HDPE collection pipe buried in a rock-filled collection trench and placed at the low point in the center of the cell, and a rock filled sump. The collection pipe would discharge into the lined sump, which contains a pump.

All leachate and storm water entering a cell would be collected in the leachate collection system and pumped to the leachate collection pond. Water collected in the leachate collection pond would be pumped out and used to wet FGD waste or used in the disposal area irrigation system that would be operated during the summer to control dust. Should the Generation Plant be out of operation, these flows could still be used in the irrigation system. The leachate collection pond would be lined with two layers of 60-mil thick HDPE geomembrane, with a leak detection layer installed between the inner and outer geomembrane liners. Leakage through the inner liner would be monitored, and the pond would be repaired if leakage exceeds a preset action leak rate.

When a portion of the disposal area has been filled to the design elevation, a cap would be put in place to prevent infiltration of moisture into the solid waste disposal area. First, a 40-mil-thick LDPE geomembrane sheet would be placed over the waste material. Second, a geocomposite drainage layer consisting of a geotextile heat-welded to a geonet would be installed. Third, a minimum 30-inch layer of silty-clay soil material would be put into place. Finally, a 6-inch layer of topsoil capable of sustaining vegetation would be placed over the cap. Then the cap would be seeded with native vegetation.

Bottom ash would be loaded into trucks from a silo or hopper and transported to the disposal area, where it would be temporarily stored in a designated part of the area. It would be recovered as needed for use in the 12-inch layer placed over the geomembrane liner for gathering leachate, or for other uses. Bottom ash is an impervious, glassy material.

Fly ash and FGD waste collected by the fabric filter also would be transported to the disposal area by truck. Before being loaded into trucks, this material would be mixed with about 20 percent water, producing a consistency similar to moist silt. After reaching the disposal area, it

Figure 2-10 Alternative Solid Waste Disposal Area

would be distributed in layers and compacted. Water from the leachate collection pond would be sprinkled over the layers of fly ash/FGD waste to assist compaction and control dust. The fly ash/FGD waste material would become somewhat hard and stable (similar to hard clay) as it dries.

2.4.2 230kV Transmission System Alternative

As indicated in the Project description above, each generating unit would be designed to generate nominally 390MW gross (350MW net) electrical capacity year round on a 24-hour per day basis. As an alternative to the three circuits of 161kV transmission lines from the Generation Plant to the Broadview Substation described in the Proposed Action (Figure 2-11), two single-circuit 230kV lines on wood pole H-frame structures in the same corridor as the Proposed Action would be constructed. This would require a new transformer and associated equipment to support connection to a higher voltage transmission line. Equipment and construction would be similar to the 161kV Transmission System described in Section 2.2.

NorthWestern Energy's Broadview Substation is connected to the transmission grid in the northwest and the Transmission System coordinated by the Western Electric Coordinating Council (WECC). The Project's proponent expects improvements would be made to the system to allow approximately 500MW to flow west towards Bonneville Power Administration's (BPA) Garrison Substation and approximately 200MW to flow south to PacifiCorp's Yellowtail Substation. Studies performed by both transmission providers have identified upgrades that are proposed and underway to support this flow.

To build the 230kV Transmission System, the Project proponent would need to apply for and receive a certificate under the Major Facility Siting Act.

This alternative most probably would result in slightly lower visual impacts, as there would be fewer conductors and slightly longer spans.

2.4.3 No-Action Alternative

Under the No-Action alternative, the Generation Plant and the 161kV Transmission System to the Broadview Substation would not be constructed. The State of Montana would not issue the Final Air Permit for the Project.

2.5 Comparison of Alternatives

The alternatives to compare are alternatives to specific design and operation components of the Proposed Action. Specifically, the Landfill Alternative is compared with the Proposed Action of placing waste into the mine after the on-site landfill is at capacity in approximately 10 years after the start of Project operations. The second alternative is a double circuit 230kV transmission system, an alternative to the Proposed Action of a three circuit 161kV transmission system.

The 230kV transmission system alternative differs from the Proposed Action 161kV transmission system in the amount of ground disturbance-related impacts and visual impacts. Ground disturbance would be slightly more with the 161kV transmission system because there would be slightly more 161kV structures, and therefore slightly more spur roads and ground

disturbance to access and construct at these structure sites. Therefore, slightly more habitat impacts would result from the Proposed Action 161kV system, and the potential to disturb cultural sites would be slightly higher, but would likely be immeasurably so.

Visual impacts would be slightly different between the Proposed Action 161kV and the 230kV transmission system alternative, but there is no visual resource preference between the two. With the Proposed Action 161kV system, there would be slightly more structures and more conductors (i.e., slightly more structure contrast), and slightly more ground disturbance, but these somewhat potentially higher visual impacts would be offset by somewhat smaller structures. Therefore, there is likely not enough difference between the 161kV and 230kV systems to state a preference visually.

There would be no difference between the two transmission systems for land use impacts, socioeconomics, or water resources, or wetlands.

For the waste disposal alternative of constructing an off-site landfill after the 10-year capacity of the on-site is utilized, the impact differences are primarily for land use, wildlife habitat, and potential risks to groundwater resources. There would be lower risks and potential impacts to environmental resources with the off-site Landfill Alternative. There are risks, unknowns, and uncertainties associated with in-mine storage of waste that could result in impacts and possible contamination to soils, water bearing geological zones, and groundwater resources. The use of lined and monitored landfill cells in the Landfill Alternative would result in less risk and less potential impact to these resources in the future.

Land uses and habitats would have slightly higher impacts with the Landfill Alternative due to permanent loss of grazing and dispersed recreation potential if this alternative were selected. This would be the case because of the previously decision and commitment for this area to be mined, and therefore the loss of this area to other land use or habitat is already planned. Other resource impacts would be similar with either the Landfill Alternative or the Proposed Action.

Table 2-5 summarizes and compares the Proposed Action and the alternatives described in Sections 2.2 and 2.4 and analyzed in detail in Chapters 3 and 4. Alternatives to design components of the Proposed Action include a waste disposal alternative and a transmission system alternative.

2.6 Selection of the Preferred Alternative

The DEQ Preferred Alternative is the Proposed Action, with the addition of the Landfill Alternative for long-term solid waste disposal instead of long-term disposal in the mine. In this alternative, solid waste would be stored in landfill cells adjacent to the generation facility site for the life of the Project (also refer to Section 2.4.1 for a description of the Landfill Alternative).

The alternative of disposing waste in the alternative landfill is preferred over the Proposed Action of long-term disposal of waste in the adjacent coalmine because it would result in the least impacts to environmental resources. The uncertainties associated with in-mine storage of waste make the Proposed Action a higher risk for causing impacts and possible contamination to soils, water bearing geological zones, and groundwater resources. In comparison, the use of lined and monitored landfill cells would minimize the risk of these impacts in the future. More

information is needed to fully understand impacts from in-mine storage. Therefore, the Landfill Alternative is preferred.

With the construction and operation of the Proposed Action or the two alternatives (i.e., Landfill and 230kV Transmission System), all resource areas, with the exception of fisheries, would experience some adverse environmental impacts (refer to Table 2-5). Impacts that would result to vegetation and wildlife would include the loss of approximately 208 acres of grass/shrubland habitat for the Proposed Action or the action alternatives. However, this habitat is common and widespread in this portion of Montana, so impacts would be low. No federally listed or state sensitive species are known to exist in the Project study areas.

Air quality impacts was not a factor in selecting the Preferred Alternative, as impacts would not be measurably different under the Proposed Action or with selection of either of the action alternatives. Air resources were identified as having the highest Project-related impacts with most impacts ranging from low to moderate. A high impact to three Class 1 Areas (i.e., Yellowstone National Park, North Absaroka Wilderness, and Northern Cheyenne Reservation) was identified from Project operations impairing visibility in these areas during specific periods each year.

Finally, the socioeconomic benefits of preferring the Proposed Action and the Landfill Alternative (i.e., the Preferred Alternative), as well as the benefits of adding the base load generation at this location and using the proposed fuel source, would outweigh the potential environmental consequences of constructing and operating the Project as the Preferred Alternative.

DEQ's preference for this alternative could change in response to public comments on the Draft EIS, new information, or analysis completed as part of the Final EIS.

Figure 2-11 Transmission System

Table 2-5 Alternatives Comparison Summary

CHAPTER 3 AFFECTED ENVIRONMENT

3.1 Introduction

This chapter describes components of the existing environment that could be affected by the Proposed Action or alternatives to the Proposed Action. The proposed Roundup Power Project (Project) consists of the construction and operation of an electricity Generation Plant, Transmission System, and associated facilities. The Project is described in detail in Section 2.2 of Chapter 2. The environmental components described include air, water, geology, soils, wetlands, vegetation, fish and wildlife, cultural, visual, noise, land use and socioeconomics.

The location and extent of the area studied depended on the resource component being evaluated. For most resource components, the Generation Plant Study Area included all of the land in Section 15, Township 6 North, Range 26 East in Musselshell County, Montana, approximately 35 miles north of Billings and 13 miles south-southeast of the City of Roundup. This includes the area needed for the Landfill Alternative. The Project site is immediately east of U.S. Route 87 and immediately north of Old Divide Road (Figure 2-1). Approximately 167 acres of land would be located within the Generation Plant fence. Other Project-related activities would occupy approximately 40 acres outside the Generation Plant fence for an estimated total of approximately 208 acres devoted to the Generation Plant. The Landfill Alternative would occupy an additional 70 acres of land adjacent to the Generation Plant.

The proposed Transmission System and 230kV Alternative were assessed within a 1.5-mile-wide corridor from the Generation Plant to the Broadview Substation for land use and visual resources. This area is 28.2 miles in length, crossing Musselshell and Yellowstone Counties (Figure 2-12). Other resources covered a similar area based on available existing data. The study areas are discussed in the Inventory Methods sections devoted to each resource component.

3.2 Air Resources

For all general purposes, the airshed for both the Generation Plant and Transmission System is considered the same; however, due to terrain features, localized weather patterns do exist but are not significant enough to report as part of the inventory results. Therefore, throughout the following sections, the Generation Plant and Transmission System are referred to as the “Study Area,” and the reader can assume that the inventory results can be used to represent the airshed for the Generation Plant and Transmission System.

3.2.1 Overview

The climate in the Study Area is continental and semiarid in nature and is typical of central and eastern Montana. The area is characterized by cold winters and warm to hot summers. Precipitation is generally light, with May and June being the wettest months. Prevailing winds blow from the southwest.

The air quality in the Study Area is well within the applicable ambient air quality standards for all criteria pollutants.

3.2.2 Inventory Methods

Temperature and precipitation data for the Study Area were obtained from the Western Regional Climate Center (WRCC). These data included monthly normals of temperature and precipitation developed by the National Climatic Data Center (NCDC) for the years 1971 through 2000. This 30-year period is the current standard period for expressing long-term normals of temperature and precipitation in the United States. Wind data were collected at the Billings Logan Airport (SAMSON database, 2002). A surface wind rose for the five-year period of 1986 through 1990 was prepared to graphically illustrate wind patterns in the area. Information obtained from the Supplemental EIS Support Document (Bull Mountain Development Company, LLC, 2002a) was used to create the following inventory results unless otherwise noted.

Sulfur dioxide (SO₂) and nitrogen dioxide (NO₂) data collected at the Project site since January 2002 have been reviewed and analyzed to characterize the current air quality in the Study Area. In addition, summaries of particulate data collected at the Project site during 1989 through 1991 were obtained and presented to characterize particulate concentrations in the area.

3.2.3 Inventory Results

Temperature and Precipitation

General meteorological conditions in the Study Area are represented by data obtained from the WRCC for Roundup and from the Weather Service Office (WSO) at Billings Logan Airport, Montana. The monthly normals of temperature and precipitation for these locations, as developed by the NCDC for the years 1971 through 2000, provide a description of general weather patterns in the region. The Roundup station is approximately 16 miles northwest of the Study Area and the Billings station is approximately 32 miles to the south.

The temperature ranges recorded at the Roundup station vary from a normal daily maximum of 86.5 degrees F in July to a normal daily minimum of 12.5 degrees F in January. At the Billings Airport, the temperature ranges recorded vary from a normal daily maximum of 85.8 degrees F in July to a normal daily minimum of 15.1 degrees F in January. Temperature data for both stations are listed in Table 3-1.

Table 3-1 also shows the normal monthly and annual precipitation data from both stations. At Roundup, the normal monthly precipitation ranges from 0.34 inch in November to 2.35 inches in May. The normal annual precipitation at Roundup is 13.25 inches. At the Billings Airport, the monthly normal precipitation ranges from 0.58 inch in February to 2.48 inches in May. The normal annual precipitation at the Billings Airport is 14.77 inches. At both locations, the heaviest precipitation amounts normally fall as rain, at times mixed with snow, in the months of May and June. Precipitation in the form of snow normally falls from November through March. Summer precipitation occurs mostly as showers and thunderstorms.

Table 3-1 Generation Plant Study Area Temperature and Precipitation

	Jan	Feb	Mar	Apr	May	Jun	Jul	Aug	Sep	Oct	Nov	Dec	Annual
Roundup, Montana NCDC 1971-2000 Monthly Normals													
Mean Max Temp (F)	36.3	42.7	50.7	60.3	69.7	79.0	86.5	86.1	74.8	62.8	45.6	37.7	61.0
Mean Min Temp (F)	12.5	17.3	24.0	32.3	41.6	49.9	54.7	53.1	42.9	33.6	22.4	14.7	33.3
Mean Temp (F)	24.4	30.0	37.4	46.3	55.7	64.5	70.6	69.6	58.9	48.2	34.0	26.2	47.2
Mean Precip (in)	0.43	0.36	0.64	1.28	2.35	2.15	1.65	1.29	1.27	1.03	0.34	0.46	13.25
Billings WSO, Montana NCDC 1971-2000 Monthly Normals													
Mean Max Temp (F)	32.8	39.5	47.6	57.5	67.4	78.0	85.8	84.5	71.8	58.9	42.7	34.5	58.4
Mean Min Temp (F)	15.1	20.1	26.4	34.7	44.0	52.5	58.3	57.3	47.1	37.2	25.6	17.7	36.3
Mean Temp (F)	24.0	29.8	37.0	46.1	55.7	65.2	72.0	70.9	59.5	48.1	34.1	26.1	47.4
Mean Precip (in)	0.81	0.58	1.12	1.74	2.48	1.89	1.28	0.85	1.34	1.26	0.75	0.67	14.77

Source: NOAA, Western Regional Climate Center, 2002

A wind rose depicting the average wind conditions for the five-year period of 1986 through 1990 at the Billings Airport is presented in Figure 3-1. This wind rose shows that the most common wind direction in the area is from the southwest, with winds blowing from that direction almost 25 percent of the time. The least common wind directions are from the east-southeast through south-southeast, with these winds blowing less than five percent of the time.

Air Quality

The State of Montana and the federal government have established ambient air quality standards for criteria air pollutants. The criteria pollutants are carbon monoxide (CO), lead (Pb), SO₂, particulate matter with an aerodynamic diameter equal to or less than 10 microns (PM₁₀), ozone (O₃), and NO₂. The federal government has also established a standard for particulate matter with an aerodynamic diameter equal to or less than 2.5 microns (PM_{2.5}).

The ambient air quality standards must not be exceeded in areas where the public has access. Table 3-2 lists the federal and Montana air quality standards. National primary standards are the levels of air quality necessary, with an adequate margin of safety, to protect the public health. National secondary standards are the levels of air quality necessary to protect the public welfare from known or anticipated adverse effects of a regulated air pollutant.

Ambient air quality standards based on annual averages must not be exceeded for any year. Compliance with short-term standards allows one exceedance per year for SO₂, PM₁₀, and CO standards (18 exceedances per 12 months for the Montana 1-hour SO₂ standard), one day with exceedances for the 1-hour O₃ standard

Monitoring levels of criteria pollutants determine the attainment status for pollutants within the Study Area. Air quality in this area is classified as attainment for all criteria pollutants. A non-attainment designation means that violations of the federal or Montana standards have been documented in the region. The nearest non-attainment area is the Laurel area to the south of the Project, which is non-attainment for SO₂. The Billings area to the south of the Project was a non-attainment area for CO but is now in attainment and operating under a maintenance plan. In addition, since 1993 the Billings-Laurel area has been the subject of an EPA-mandated revision to Montana's State Implementation Plan (SIP) to establish new emission limits for SO₂ for area industries so that compliance with the federal air quality standards for SO₂ can be demonstrated. Montana has submitted its proposed SIP revision to the EPA, where it is currently being reviewed.

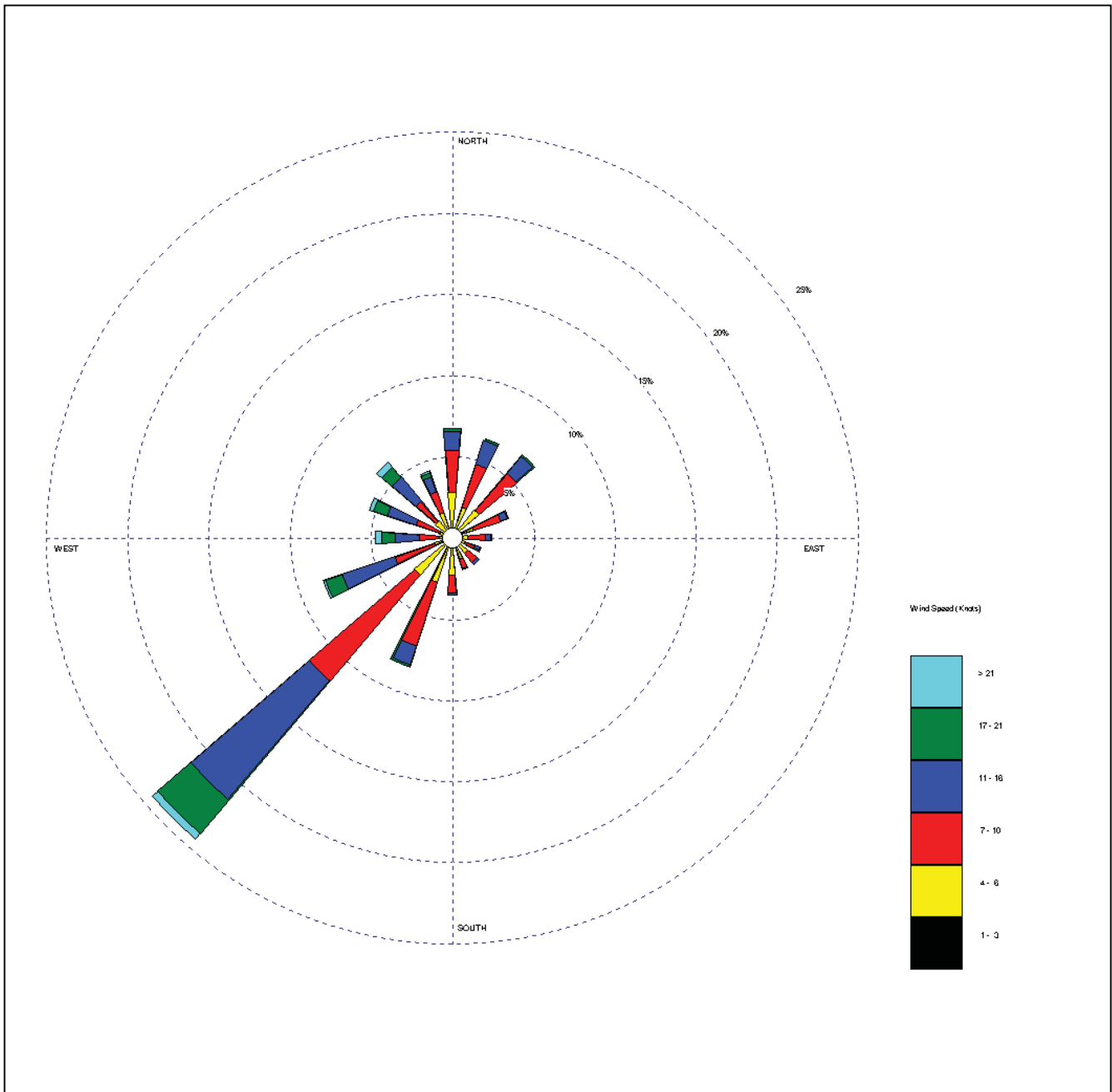

Figure 3-1 Billings WSO, Montana, Wind Rose, 1986-1990

Table 3-2 Ambient Air Quality Standards

Pollutant	Averaging Time	Concentration	Comments
Ozone	8 hours	157 $\mu\text{g}/\text{m}^3$ (0.08 ppm)	National Primary and Secondary Standard
	1 hour	235 $\mu\text{g}/\text{m}^3$ (0.12 ppm)	National Primary and Secondary Standard
		196 $\mu\text{g}/\text{m}^3$ (0.10 ppm)	Montana Standard
Carbon monoxide	8 hours	10,000 $\mu\text{g}/\text{m}^3$ (9.0 ppm)	National Primary and Secondary Standard and Montana Standard
	1 hour	40,000 $\mu\text{g}/\text{m}^3$ (35 ppm)	National Primary Standard
		26,450 $\mu\text{g}/\text{m}^3$ (23 ppm)	Montana Standard
Nitrogen dioxide	Annual arithmetic mean	100 $\mu\text{g}/\text{m}^3$ (0.053 ppm)	National Primary and Secondary Standard
		94 $\mu\text{g}/\text{m}^3$ (0.05 ppm)	Montana Standard
	1 hour	564 $\mu\text{g}/\text{m}^3$ (0.30 ppm)	Montana Standard
Sulfur dioxide	Annual arithmetic mean	80 $\mu\text{g}/\text{m}^3$ (0.03 ppm)	National Primary Standard
		52 $\mu\text{g}/\text{m}^3$ (0.02 ppm)	Montana Standard
	24 hours	365 $\mu\text{g}/\text{m}^3$ (0.14 ppm)	National Primary Standard
		262 $\mu\text{g}/\text{m}^3$ (0.10 ppm)	Montana Standard
	3 hours	1,300 $\mu\text{g}/\text{m}^3$ (0.5 ppm)	National Primary Standard
	1 hour	1,300 $\mu\text{g}/\text{m}^3$ (0.5 ppm)	Montana Standard
Particulate matter as PM10	Annual arithmetic mean	50 $\mu\text{g}/\text{m}^3$	National Primary Standard and Montana Standard

Pollutant	Averaging Time	Concentration	Comments
	24 hours	150 µg/ m ³	National Primary Standard and Montana Standard
Particulate matter as PM2.5	Annual arithmetic mean	15 µg/ m ³	National Primary Standard and Montana Standard
	24 hours	65 µg/ m ³	National Primary Standard and Montana Standard
Lead	Quarterly arithmetic mean	1.5 µg/ m ³	National Primary and Secondary Standard
	90-day average	1.5 µg/ m ³	Montana Standard

Source: Administrative Rules of Montana, Title 17, Chapter 8, Sub-chapter 2, Ambient Air Quality, 1996; Title 40 Code of Federal Regulations

Air Quality Monitoring Data

Ambient air quality data have been collected at the Study Area by McVehil-Monnett Associates for FGS & Associates, LLC. NO₂ and SO₂ levels have been measured at the Project site since January 2002. None of the measured concentrations was above the ambient standards during the monitoring period. Table 3-3 lists the averaged air quality monitoring data from January through mid-July 2002.

Table 3-3 Air Quality Monitoring Data

Month	Pollutant	24-Hour Maximum (ppm)	3-Hour Maximum (ppm)	1-Hour Maximum (ppm)	Monthly Arithmetic Mean (ppm)
Jan 2002	SO ₂	---	---	---	---
	NO ₂	0.003	0.008	0.008	0.001
Feb 2002	SO ₂	0.002	0.002	0.003	0.000
	NO ₂	0.002	---	0.003	---
Mar 2002	SO ₂	0.003	0.010	0.016	0.001
	NO ₂	0.002	0.005	0.006	---
Apr 2002	SO ₂	0.002	0.007	0.010	0.000
	NO ₂	0.002	0.005	0.007	0.001
May 2002	SO ₂	0.000	0.002	0.003	0.000
	NO ₂	0.003	0.003	0.004	0.001
Jun 2002	SO ₂	0.003	0.005	0.007	0.001
	NO ₂	0.002	0.002	0.004	0.000
Jul 1-15, 2002	SO ₂	0.001	0.001	0.001	0.000

NO ₂	0.002	0.002	0.003	0.000
-----------------	-------	-------	-------	-------

Source: McVehil-Monnett Associates, Ambient Air Quality reports, 2002

In addition, background air quality monitoring for particulates was conducted in the Study Area by Meridian Minerals Company) from 1989 through 1992 (Lorenzen, 2002). This monitoring included both total suspended particulates (TSP) and PM₁₀. These data are summarized in Table 3-4. All PM₁₀ values are well below the ambient air quality standards.

Table 3-4 Particulate Monitoring Data (µg/m³)

Year	Parameter	Highest Reading	Second-Highest	Annual Average	No. of Samples
1989	TSP	39	33	14	51
	PM ₁₀	53*	19	9	51
1990	TSP	59	58	13	59
	PM ₁₀	29	27	9	57
1991	TSP	42	39	14	56
	PM ₁₀	24	21	9	57

*This high PM₁₀ value was recorded on June 27; no TSP value was recorded on that date.

PSD Classification

The area surrounding the Project site is a designated Class II area as defined by the Federal Prevention of Significant Deterioration of Air Quality (PSD) program. The PSD Class II designation allows for moderate growth or degradation of air quality within certain limits above baseline air quality standards. Industrial sources proposing construction or modifications must demonstrate that the proposed emissions would not cause significant deterioration of air quality in all areas. A Class I designation provides the most protection to pristine lands, limiting the increment above baseline pollution levels. The standards for significant deterioration are much stricter for Class I areas than for Class II areas.

The nearest mandatory federal Class I area to the Project would be the UL Bend Wilderness Area, located approximately 130 kilometers (~81 miles) northeast of the site. Yellowstone National Park (YNP), also a mandatory federal Class I area, is about 180 kilometers (~112 Miles) southwest of the site, and the North Absaroka Wilderness is also approximately 180 kilometers southwest of the site. In addition, the Northern Cheyenne Indian Reservation, located approximately 130 kilometers (~81 miles) to the southeast, is a designated Class I area. Figure 3-2 shows the Class I areas relative to the Project.

The UL Bend Wilderness area comprises 20,819 acres of land characterized by breaks (badlands), steep-sided forested coulees, prairie grasslands, cottonwood river bottoms, and an abundance of wildlife. The UL Bend Wilderness is part of the UL Bend National Wildlife Refuge, which in turn is part of the larger Charles M. Russell National Wildlife Refuge. Elevations in the UL Bend Wilderness are approximately 2,340 feet above sea level.

Yellowstone National Park is the nation's first and oldest national park. Encompassing 2,219,791 acres, the Park is characterized by geothermal features, mountain lakes, abundant wildlife, and rugged mountains with peaks in excess of 10,000 feet.

The North Absaroka Wilderness is located in Wyoming near the northeastern boundary of Yellowstone National Park. Encompassing approximately 350,500 acres, the Wilderness is characterized by mountain lakes, abundant wildlife, and rugged mountains with peaks in excess of 10,000 feet.

The Northern Cheyenne Indian Reservation was established in 1884. With an area of 444,775 acres in south-central Montana, topography of the reservation varies from grass covered rolling hills to moderately high and steep hills and narrow valleys. Elevations range from 3,000 to 4,500 feet above sea level.

Offsite Pollution Sources

The EPA's National Emission Trends (NET) 1999 database contains annual emission estimates from point, area, and mobile sources, with no minimum emission threshold required for listing. In the counties around the Study Area, the NET 1999 database lists 17 stationary sources in Yellowstone County, seven in Rosebud County, three in Big Horn County, three in Stillwater County, two in Carbon County, and one in Musselshell County. Of these 33 sources, 17 are major for criteria pollutants.

Eight of the 33 facilities are also listed on the EPA's 1999 National Toxics Inventory (NTI) database. The NTI is an emission inventory for stationary and mobile sources that emit hazardous air pollutants (HAPs). Four of these facilities are also major for HAPs, emitting more than 10 tons per year of any one HAP or 25 tons per year of two or more HAPs. Both the NET and NTI databases are updated every three years. Table 3-5 presents a list of the major facilities, their location, nature of business, and the pollutant(s) emitted.

In addition to the major sources listed below, a new 113 MW coal-fired generation plant has recently been permitted near Hardin, Montana. By permit, construction of the generation plant must commence before June 12, 2005.

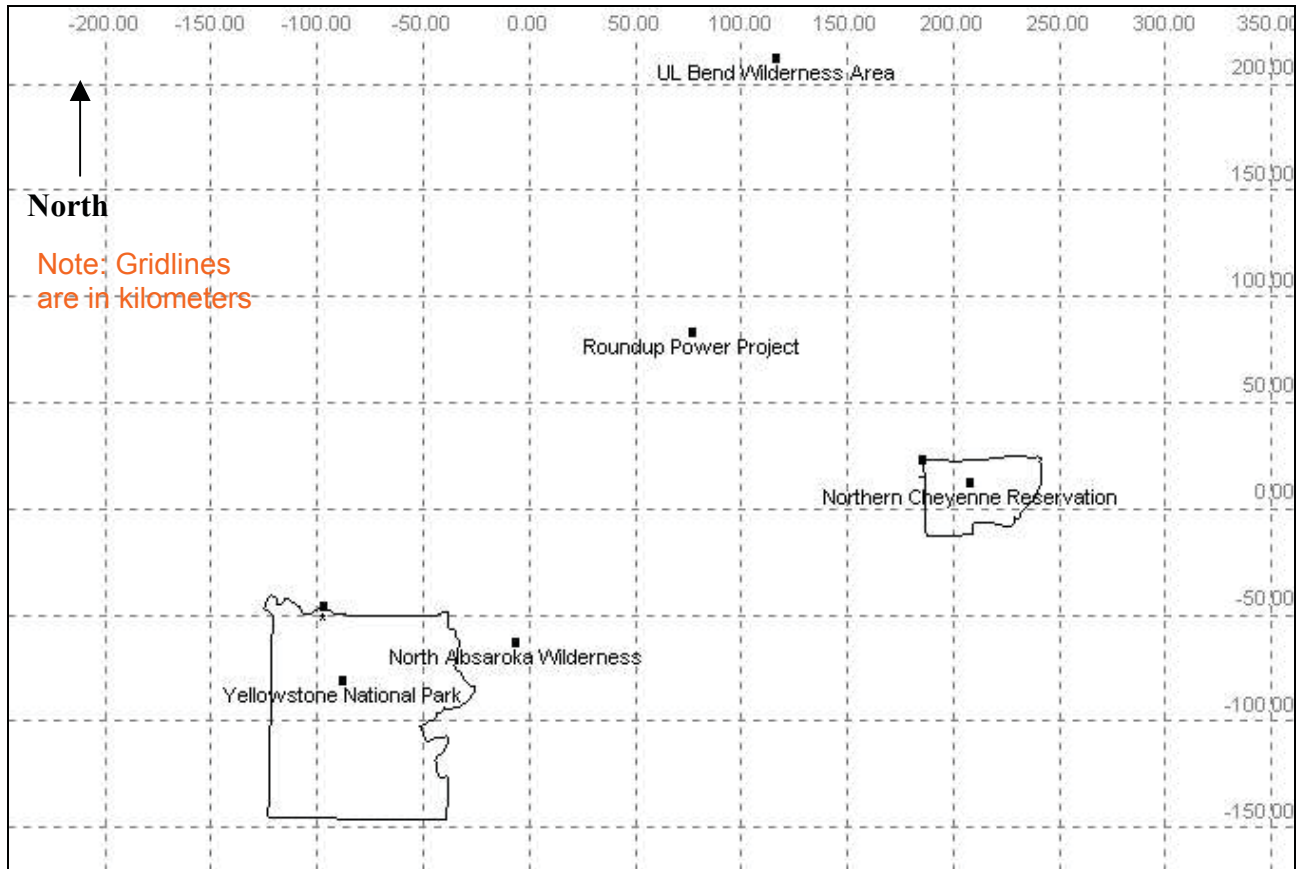

Figure 3-2 Class I Areas of Concern for the Roundup Power Project

Table 3-5 Major Nearby Facilities

Facility Name	Facility Location	Nature of Business	Pollutants Emitted
Montana Sulphur and Chemical	East Frontage Road Billings, Montana	Industrial Organic Chemicals	CO, NO ₂ , PM ₁₀ , SO ₂ , VOC, PM _{2.5}
Conoco Phillips	401 23 rd Street Billings, Montana	Petroleum Refining	CO, NO ₂ , PM ₁₀ , SO ₂ , VOC, PM _{2.5} , HAPs
Cenex Harvest States Co-op.	Highway 212 South Laurel, Montana	Petroleum Refining	CO, NO ₂ , PM ₁₀ , SO ₂ , VOC, PM _{2.5} , HAPs
Western Sugar Co.	3020 State Avenue Billings, Montana	Beet Sugar	CO, NO ₂ , PM ₁₀ , SO ₂ , VOC, PM _{2.5}
PPL Montana-Corette/Bird	301 Charlene Street Billings, Montana	Electric Services	CO, NO ₂ , PM ₁₀ , SO ₂ , VOC, PM _{2.5} , HAPs
PPL Montana-Colstrip Units #1 & #2	P.O. Box 38 Colstrip, MT 59323	Electric Services	CO, NO ₂ , PM ₁₀ , SO ₂ , VOC, PM _{2.5} , HAPs
PPL Montana-Colstrip Units #3 & #4	P.O. Box 38 Colstrip, MT 59323	Electric Services	CO, NO ₂ , PM ₁₀ , SO ₂ , VOC, PM _{2.5} , HAPs

Facility Name	Facility Location	Nature of Business	Pollutants Emitted
Colstrip Energy Ltd. Partnership	Rosebud Power Plant Colstrip, MT 59323	Electric Services	CO, NO ₂ , PM ₁₀ , SO ₂ , VOC, PM _{2.5} , HAPs
Western Energy	Rosebud Mine Colstrip, MT 59323	Bituminous Coal and Lignite	CO, NO ₂ , PM ₁₀ , SO ₂ , VOC, PM _{2.5} , HAPs
Exxon Mobil	700 Exxon Road Billings, Montana	Petroleum Refining	CO, NO ₂ , PM ₁₀ , SO ₂ , VOC, PM _{2.5} , HAPs
Yellowstone Energy Ltd. Partnership	2215 N. Frontage Rd. Billings, Montana	Electric Services	CO, NO ₂ , PM ₁₀ , SO ₂ , VOC, PM _{2.5} , HAPs
Decker Coal Company	Decker Mine Decker, MT 59025	Bituminous Coal and Lignite	CO, NO ₂ , PM ₁₀ , SO ₂ , VOC, PM _{2.5}
Big Sky Coal Company	P.O. Box 97 Colstrip, MT 59323	Bituminous Coal and Lignite	CO, NO ₂ , PM ₁₀ , SO ₂ , VOC, PM _{2.5}
Westmoreland Resources	East of Hardin Hardin, MT 59034	Bituminous Coal and Lignite	CO, NO ₂ , PM ₁₀ , SO ₂ , VOC, PM _{2.5}
Spring Creek Coal	Spring Creek Mine Decker, MT 59025	Bituminous Coal and Lignite	CO, NO ₂ , PM ₁₀ , SO ₂ , VOC, PM _{2.5}
Williston Basin-Hardin Compressor Sta.	P.O. Box 358 Hardin, MT 59034	Natural Gas Transmission	CO, NO ₂ , PM ₁₀ , SO ₂ , VOC, PM _{2.5}
St. Labre Indian School	P.O. Box 48 Ashland, MT 59003	Nonclassifiable Establishments	CO, NO ₂ , PM ₁₀ , SO ₂ , VOC, PM _{2.5}

EPA Office of Air and Radiation, 2002

3.3 Water Resources

3.3.1 Overview

The Generation Plant would be located along the crest of the drainage divide between the Musselshell and Yellowstone rivers. There are no surface water bodies within the Generation Plant Study Area.

There are two main aquifers of interest in the Generation Plant Study Area. The primary water sources for domestic wells are the shallow sandstone aquifers in the Tongue River member of the Fort Union Formation. These aquifers are often discontinuous, or perched, with limited areal extent. Other aquifers may be present within the underlying Cretaceous sandstone units; however, no production wells have been drilled into these sediments around the Generation Plant Study Area. Deep drilling efforts and production testing performed by oil exploration companies have identified a very productive water-bearing zone in the Madison Group limestone beds. The Madison aquifer is the proposed water source for the Project.

3.3.2 Inventory Methods

The water resources at the site were reviewed through publications by the U.S. Geological Survey (USGS), the Montana Bureau of Mines and Geology (MBMG, 2002), and other sources

such as oil company reports. The well inventories and well log records were observed at the Montana Department of Environmental Quality (DEQ), the Montana Department of Natural Resources and Conservation (DNRC), and the USGS. Many of the monitoring well records included water quality information. The surface water inventory was compiled by review of surface maps and aerial photography.

Other various reports and documents including the Supplemental EIS Support Document (Bull Mountain Development Company, LLC, 2002a), Bull Mountains Mine FEIS (Montana Department of State Lands, 1992), and the Railroad Spur Checklist EA (DNRC, Trust Land Management Division, 2002) were also used in evaluating the existing conditions in the Generation Plant Study Area. USGS 7.5 minute topographical maps and aerial photography were also obtained and analyzed to assist in this inventory. On-site observation was used to confirm conditions on the ground.

3.3.3 Inventory Results

Generation Plant

Surface Water

The proposed Generation Plant would be located on a flat ridge separating the upper reaches of Halfbreed Creek and Rehder Creek. The Yellowstone River is located approximately 35 miles south; the Musselshell River is located 15 miles to the north. The closest flowing water is found in Rehder Creek approximately three miles northwest of the site. The average annual precipitation for the area is approximately 14 inches of rainfall and snowmelt (NOAA, 2002). No surface water bodies exist within the Generation Plant Study Area. All of the drainages lack defined bed and banks.

Groundwater

In the Generation Plant Study Area, two main groundwater-bearing aquifers occur within 1,600 feet of the surface. They are the Tongue River member of the Fort Union Formation and the Hell Creek Formation. These aquifers overlie the impermeable shales of the Cretaceous Montana Group. Water production rates from wells screened in these aquifers are reported by the MBMG (MBMG, 2002) to range from 1 to 15 gallons per minute (gpm). The low production rates limit the use of these wells to domestic water and livestock watering.

This Project would not use any water from these shallow aquifers because of the low yield rates demonstrated in surrounding domestic wells. There are presently many shallow domestic and stock groundwater wells that penetrate the Fort Union Formation and a few additional wells in the Hell Creek Formation (MBMG, 2002).

Recharge in these aquifers originates from infiltration of precipitation and minor amounts from upward migration of water from Cretaceous sediments. There is no documented evidence suggesting a hydrologic connection between the Tertiary aquifers and the deeper Madison aquifer. In the Generation Plant Study Area, they are separated by thousands of feet of low permeability shales and siltstones. Water quality from monitoring well samples in the Fort Union aquifer range from 852 to 2,056 parts per million (ppm) total dissolved solids (TDS) (MBMG, 2002).

The proposed Generation Plant water source is from the Madison Group, the top of which lies approximately 7,900 feet below ground surface (bgs) (Feltis, 1984). Approximately four to six 8,600-foot wells drilled near the proposed Generation Plant would penetrate into the Charles and Mission Canyon formations, utilizing the most likely zones of high porosity and permeability that would favor good production.

The Madison Group in Montana constitutes a large regional aquifer. Water within the Madison Group in the Project vicinity occurs under confined conditions. Due to the hydrostatic pressure within the aquifer, wells screened in the Madison Group would likely have water levels that reach above the level of the top of the aquifer. Oil wells screened in this aquifer near the Project have water levels measured within 300 feet of ground surface (Lee Techni-Coal, 1993). Artesian flow is reported in wells drilled to the south in the Billings area.

Groundwater in the Madison flows through solution channels developed along joints and fractures in the limestone, and through interconnected caverns (Feltis, 1993). Well tests in this aquifer regionally produce water flows from 70 gpm to 1,200 gpm (Lee Techni-Coal, 1993, and MBOG, 2002).

The water temperatures in the Madison aquifer are approximately 175°F at a depth of 8,500 feet near the Generation Plant (Lee Techni-Coal, 1993).

The water in this geologic formation contains high concentrations of TDS. Analysis of water from wells in the region varies from 2800 to 6500 ppm TDS. Sulfate and bicarbonate are the dominant anions, with calcium and sodium the dominant cations (Lee Techni-Coal, 1993).

Transmission System

Surface Water

It is anticipated that the Transmission System would connect with the Broadview Substation west of the Generation Plant following the Bull Mountain coal railroad spur right-of-way. The railroad spur right-of-way is primarily located in uplands; however, several small drainages may be crossed. This right-of-way would neither cross nor be adjacent to any perennial stream system. Generally, the corridor is located in high areas where intersecting ephemeral channels drain small catchment areas. The upper Goulding and Dean creeks provide northerly drainage while the upper Razor Creek system provides the only major drainage to the southeast along the proposed corridor. A portion of the proposed transmission line alignment crosses the Hay Basin lakebed east of State Highway 3 approximately 12 miles east of Broadview.

Groundwater

Groundwater was not assessed within the Transmission System Study Area.

3.4 Earth Resources

3.4.1 Overview

The Project would be located in the Bull Mountain Basin of south-central Montana (Stricker, 1999). The Bull Mountain Basin contains marine and near-shore fluvial deposits that mark the retreat of a shallow sea and emergence of a low-gradient coastal plain environment in the Late

Cretaceous and early Tertiary periods. The basin is a positive topographic feature ranging in elevation from approximately 3,200 to 4,000 feet above mean sea level. Topography in the basin is dominated by ponderosa pine covered upland areas underlain by resistant sandstone beds. The upland areas have been dissected by tributary streams of the Musselshell and Yellowstone rivers, resulting in good exposures of basin sediments in these drainages.

3.4.2 Inventory Methods

Data for this section were obtained from review of the Supplemental EIS Support Document (Bull Mountain Development Company, LLC, 2002a), publications from the USGS, the MBMG, and the DNRC's Board of Oil and Gas Conservation (BOGC), and from Meshnick et al (1972). Figure 3-3 illustrates soil classifications in the Generation Plant Study Area.

3.4.3 Inventory Results

Generation Plant

Geology

An overview of the site stratigraphy is provided in Table 3-6. Data for Table 3-6 were obtained from Wilde and Porter (2000), and the BOGC (2002). The table illustrates the time and depth relationships of the rock units present beneath the site. The table is arranged from top to bottom so that the youngest unit appears on top, and the oldest unit on the bottom. Individual rock units are identified in the "Formation" column. The approximate age of the rocks is given in years before present in the "Time" column. The approximate depth to the top of selected units in the table is included in the "Depth" column.

The site is underlain by the Tongue River member of the Paleocene Fort Union Formation. The Tongue River member is comprised of thick- to thin-bedded sandstone, shale, siltstone, and coal. The total thickness of the Tongue River member ranges from 1,600 to greater than 2,050 feet in the Bull Mountains (Stricker, 1999). The Generation Plant would be constructed on interbedded sandstone and shale near the middle of the Tongue River member.

The Mammoth coal bed, ranging from 5 to 16 feet thick, occurs within this unit and is the proposed coal source for the Generation Plant. At least 12 other mappable coal beds occur within the Tongue River member (Stricker, 1999). Where the coal beds outcrop at the surface, they are susceptible to ignition from prairie fires. These coal bed fires advance slowly underground through the coal seams, metamorphosing the overlying siltstone and shale into the distinctive red clinker observed on hillsides and road cuts in the vicinity of the Generation Plant Study Area (Meridian Minerals, 1991).

The Tongue River is the uppermost of three members comprising the Fort Union Formation. In descending order, the other members are the Lebo shale, and the Tullock sandstone. The Tullock is not preserved in the mine area. Aggregate thickness of the Fort Union Formation ranges from 1,800 to greater than 2,350 feet (Stricker, 1999).

The Fort Union Formation is underlain by a thick sequence of interbedded shale and sandstone from various Cretaceous formations (Table 3-6). The sandstone intervals within this and the Fort

Union formations serve as aquifers for the local water wells and springs. A discussion of the area hydrostratigraphy is included in Section 3.3.3.

Rocks older than Cretaceous age do not outcrop near the Project. However, due to the number of oil and gas wells in the area, the subsurface geology is fairly well understood. Records of more than 300 oil and gas wells were reviewed to compile Table 3-6 (BOGC, 2002).

Of interest for this Project is the presence of the Mississippian age Madison Group. These rocks occur over a wide area in Montana, North Dakota, and Wyoming. The Madison Group is comprised of four formations, in descending order the Charles, Mission Canyon, Lodgepole, and Bakken. Madison Group lithologies range from interbedded siltstone and limestone of the Charles, Lodgepole, and Bakken, to massive limestone of the Mission Canyon (Balster, 1971). Because of their brittle nature and propensity to fracture under stress, the Madison Group formations have generally widespread and well-developed porosity and permeability.

These properties allow the formations to collect and transmit liquids, such as petroleum and water, over long distances. The Madison is a significant oil producer in eastern Montana and western North Dakota (Balster, 1971).

Due to its economic importance, the top of the Madison Group has been mapped in the Roundup 1 x 2 quadrangle (Feltis, 1984). In the Generation Plant Study Area, the top of the Madison occurs approximately 7,900 feet bgs (Feltis, 1984). The Madison is the proposed water source for the Generation Plant. Refer to Section 3.3.3 for a discussion of the Madison aquifer.

Rocks of the Bull Mountain Basin are gently folded in a shallow syncline with a northwest-trending axis. Wilde and Porter (2000) indicate the beds locally dipping northeast toward the syncline axis some six miles northeast of the Generation Plant. Based on measurements during the site reconnaissance, outcrops near the Project site dip very gently, generally less than 5 degrees. Good examples of bedding are present in road cuts along Highway 87, and in the drainage ravines near the Project site.

Table 3-6 Site Stratigraphy

Era ¹	Period ¹	Epoch ¹	Time ²	Depth ³	Member ⁴	Formation ⁴	Group ⁴	
Cenozoic	Quaternary	Holocene	0 to 8,000 years					
		Pleistocene	8,000 years to 1.8 Ma					
	Tertiary	Pliocene	5.3 to 1.8 Ma					
		Miocene	23.8 to 5.3 Ma					
		Oligocene	33.7 to 23.8 Ma					
		Eocene	55.5 to 33.7 Ma					
		Paleocene	65 to 55.5 Ma			Tongue River Lebo Shale	Fort Union	
Mesozoic	Cretaceous		145 to 65 Ma	1,194				
				1,888		Hell Creek	Montana	
						Bearpaw Shale		
						Judith River		
						Claggett Shale		
						Eagle Sandstone		
						Telegraph Creek		
					4,563		Niobrara Shale	Colorado
							Carlile Shale	
							Greenhorn	
					Belle Fourche Shale			
					Mowry Shale			
					Thermopolis Shale			
				6,498		Muddy Sandstone		
					Skull Creek Shale			
					Dakota Sandstone			
					(1st Cat Creek)			
					Kootenai			
	Jurassic		213 to 145 Ma	7,260				
							Swift	Ellis
							Rierdon	
					Piper			
	Triassic		248 to 213 Ma			Nesson		
Paleozoic	Permian		286 to 248 Ma			Not Present		
	Pennsylvanian		325 to 286 Ma	7,617		Tyler	Amsden	
	Mississippian		360 to 325 Ma	7,900			Heath	Big Snowy
							Otter	
							Kibbey	
							Charles	Madison
				Mission Canyon				
						Lodgepole		
						Bakken		
		Devonian		410 to 360 Ma	9,250		Three Forks	
						Birdbear	Jefferson	
					Duperow			
					Souris			
	Silurian		440 to 410 Ma			Interlake		
	Ordovician		505 to 440 Ma			Stony Mountain	Big Horn	
					Red River			
						Winnipeg Sandstone		
	Cambrian		544 to 505 Ma			Emerson		
Precambrian			2500 to 544 Ma			Flathead		
			3800 to 2500 Ma			Belt Supergroup		

From Montana Department of Natural Resources and Conservation, Board of Oil and Gas Conservation web site <http://boggc.dnrc.state.mt.us>.

- 1 Specific time intervals
- 2 Time expressed in years before present. Ma = million years ago
- 3 Approximate depth in feet from ground surface
- 4 Rock unit names

Soils

Soil development is a function of climate, parent material, topography, vegetation, soil organisms, and time (Montagne et al. 1982). Soils in Montana are strongly influenced by parent material and topography. The arid climate, which ranges from very hot to very cold, directly affects vegetation production and soil organism activity.

Soil characteristics pertinent to the construction and operation of the proposed Project are slope, topsoil depth, texture, and depth to the water table. Soil characteristics of less importance to construction, but important to reclamation potential, include permeability, drainage and wind and water erosion hazards. A summary of these properties is included in Table 3-7.

Table 3-7 Soils Engineering Properties and Classifications: Generation Plant Study Area, Musselshell County, Montana

Soil Name and (Number)	Generalized Depth (in)	USCS	Perm (in/hr)	Shrink/Swell Potential	Potential Source of Topsoil	Wind Erodibility	Water Erodibility	Foundations for small buildings	Septic Tank Absorption Fields	Sewage Lagoons/Farm Ponds
Doney-cabbamacar Loams (281D)	10-60	CL-ML	0.6-2	Poor to Fair	Poor to Good	Erodible to Very slightly erodible	Moderately erodible	Very to Somewhat limited	Very to Somewhat limited	Very to Somewhat limited
Cabbadoney Loams (285F)	10-40	CL-ML	0.6-2	Poor to Very limited	Poor	Erodible to Slightly erodible	Moderately erodible	Very limited	Very limited	Very limited
Cabbarvon Loams (289F)	10-40	CL-ML	0.6-2	Poor to Very limited	Poor	Erodible to Very slightly erodible	Moderately erodible	Very limited	Very limited	Very limited

Source: Lee Techni-Coal. 1991; Meshnick, J.C., F.T. Miller, H. Smith, L. Gray, and W.C. Bourne. 1972

There is no published soil survey for Musselshell County. The Supplemental EIS Support Document (Bull Mountain Development Company, LLC, 2002a), and the US Department of Agriculture Natural Resources and Conservation Service (NRCS) on-line database, were sources of information for this report. Soil surveys for the Mine (Lee Techni-Coal 1991; Montana Department of State Lands [MDSL] 1992a, b) used onsite soil surveys supplemented by information provided by the Soil Conservation Service office in Roundup, and the published soil survey for Yellowstone County (Meshnick et al. 1972).

These studies reported that soils near the Mine are generally well developed, and are predominantly loams, silty loams, or sandy loams, with an occasional increase in fines to silty clay. Soils are more shallow along upper slopes and fans and deeper on lower terraces and drainage bottoms. A similar description would apply to the proposed Project, which is adjacent to the Mine project.

Soils series in the Bull Mountains have been re-named and re-mapped since the earlier studies (Bull Mountain Development Company, LLC., 2002a). The soils series potentially affected by the proposed Project are depicted in Figure 3-3. Descriptions of these series, along with the

acreage to be affected by the Project, are given below. These soils are primarily rangeland soils; none are considered to be prime farmland (NRCS designation) or highly productive (MDSL 1992a).

Table 3-8 Soils Series Descriptions, Roundup Power Project Disturbance Area

Mapping Unit	Mapping Unit Name	Approximate Disturbed Acreage ¹
B	Cabba-Barvon loams, 4%-65% slopes	68.2
C	Cabba-Doney loams, 8%-45% slopes	29.3
D	Doney-Cabba-Macar loams, 4%-15% slopes	110.7
Total		208.2

Soils Series

Doney: Consists of moderately deep, well-drained soils found from 2,900 to 5,400 feet in elevation that formed in residuum and colluvium from semi-consolidated interbedded sandy and silty sedimentary beds. The surface layer is a light brownish gray loam, 0-4 inches thick, underlain by very pale brown loams 4-25 inches thick. Depth to bedrock to 20-40 inches. Clay content of the A horizon is 10-35%, permeability is moderate, and runoff is very low to high depending on slope. Used primarily for rangeland.

Cabba: Consists of shallow, well-drained soils found from 1,600 to 6,800 feet in elevation, which formed in residuum and colluvium from semi-consolidated, loamy sedimentary beds. The surface layer is a grayish brown loam, 0-3 inches thick, underlain by a light brownish gray to pale brown loams 3-15 inches thick. EC of the A horizon is 0-4 mmhos/cm, clay content is 10-35%, permeability is moderate, and runoff is very low to high depending on slope. Used primarily for rangeland.

Macar: Consists of very deep, well-drained soils found from 1,900 to 4,700 feet in elevation, that formed in alluvium and colluvium mainly derived from semi-consolidated sandstone and siltstone sedimentary beds. The surface layer is a grayish brown clay loam, 0-7 inches thick, underlain by grayish brown and light olive gray loams 7-38 inches thick. EC of the A horizon is 0-2 mmhos/cm, clay content is 18-35%, and permeability is moderate. Used primarily for rangeland.

Barvon: Consists of moderately deep, well drained soils found from 2,300 to 4,500 feet in elevation, that formed in residuum derived from weakly consolidated interbedded sandy and silty sedimentary beds and semi-consolidated shale. The surface layer is a dark grayish brown clay loam, 0-4 inches thick, underlain by grayish brown, pale brown and light yellowish brown loams 4-34 inches thick. Depth to bedrock to 20-40 inches. Clay content is 20-27%, and permeability is moderate. Used primarily for ponderosa pine forest.

Transmission System

Geology

The Transmission System Study Area is underlain by rocks for the Fort Union Formation until it descends from the timbered upland area of the Bull Mountains to the near-level basin region to the west. Surficial geology of the basin region includes the Recent lake basin sediments, the Tullock member of the Fort Union Formation, the Lance and Fox Hills members of the Hell Creek Formation, and the Bearpaw Formation. The time and depth relationship of these units is illustrated on Table 3-6.

The lake sediments are composed of unconsolidated sand, silt, and clay. They are deposited in a series of lake beds that form during above average precipitation years. These lakes develop because there are no streams that drain this basin area, and during wet years, the water accumulates at the low points in the basin.

The Tullock, Lance and Fox Hills members are composed of interbedded sandstone, siltstone, and clay, and the Bearpaw Formation is composed of shale.

The structural regime changes once the alignment descends to the basin floor. The basin floor rocks are gently folded into a paired sequence of northwest-trending anticlines and synclines. The limbs of these folds generally have dips of less than 5° (Wilde and Porter, 2000).

The alignment crosses a series of old, inactive faults in the basin area. The faults are high angle, normal faults that trend northwest, similar to the folds. Wilde and Porter (2000) do not include an estimation of displacement across these faults.

Soils

Soils data for the Transmission System Study Area were obtained by review of the major soil associations from Meshnick, *et al* (1972) for Yellowstone County, and by projecting the soil units from Yellowstone County into similar topography in the unmapped Musselshell County area.

In Yellowstone County, the alignment traverses two soil associations: the Vananda-McKenzie-Arvada association and the Cushman-Bainville association. The Vananda-McKenzie-Arvada association consists of level to gently sloping deep clays to loams over clay. This association occurs on terraces, fans, and dry lake basins. The Cushman-Bainville association consists of undulating to rolling moderately deep loams that have a clay loam subsoil or are underlain by clay loam and silty loam. This association occurs on shale uplands.

In Musselshell County the alignment traverses the Cushman-Bainville association described above, and the Bainville-Elso-McRae association and the Bainville-Travessilla-Rock land association. The Bainville-Elso-McRae association is composed of undulating to hilly, moderately deep to shallow loams and clay loams underlain by silt loam to silty clay loam, and deep soils that are loam throughout. This association occurs on shale and sandstone uplands. The Bainville-Travessilla-Rock land association consists of moderately steep and steep, moderately deep and shallow loams and fine sandy loams underlain by clay loam to fine sandy loam. This association occurs on sandstone and shale rock lands.

Figure 3-3 Soils

3.5 Botanical and Wetland Resources

3.5.1 Overview

This section presents an overview of the botanical and wetland resources in the Generation Plant and Transmission System study areas. The main purpose of this section is to identify existing vegetation and wetland features in the Generation Plant Study Area that could be affected by construction and operation of the Project.

3.5.2 Inventory Methods

Information contained in the Supplemental EIS Support Document (Bull Mountain Development Company, LLC, 2002a), served as the basis for this inventory. Other various reports and documents including the Bull Mountains Mine FEIS (Montana Department of State Lands, 1992) and the Railroad Spur Checklist EA (DNRC, Trust Land Management Division, 2002) also were used in evaluating the existing conditions in the Generation Plant Study Area. USGS 7.5-minute topographical maps and aerial photography were obtained and analyzed to assist in this inventory. The Montana Natural Heritage Program (Montana Natural Heritage Program, 2002b) provided information on sensitive plant species. On-site observation was used to confirm conditions on the ground. There is no National Wetland Inventory data currently available for the Generation Plant Study Area. Figure 3-4 illustrates vegetation types in the Generation Plant Study Area.

3.5.3 Inventory Results

Generation Plant

From on-site soils and vegetation surveys, it has been determined that there are no identified wetland resources within the Generation Plant Study Area.

Vegetation within the Generation Plant Study Area was qualitatively surveyed January 10 and 11, 2002, to map community types and identify noxious weed populations. For consistency with the adjacent Mine Project, vegetation community type names and mapping symbols used for the baseline mine inventory were used for mapping the Generation Plant Study Area. Table 3-9 depicts vegetation community types within the Generation Plant Study Area. Thirteen community types were identified and mapped, as listed in Table 3-9. Community types are described and cover and production data are presented in the Bull Mountains Mine application and are summarized in the draft and final environmental impact statements for the mine and railroad. A large portion of the Generation Plant Study Area was burned in 1984 when several thousand acres burned in the Bull Mountains. The 1984 fire, in combination with topographic and edaphic diversity, has resulted in a mosaic of community types, with types frequently intergrading with each other. Vegetation types identified within the Generation Plant Study Area are common and widespread in the Bull Mountains and eastern Montana.

A portion of the Generation plant site is located on a broad ridge that previously was plowed and converted to hay meadow or tame pasture. The plowed area has not been maintained for agriculture, and seeded species (probably intermediate wheatgrass and/or crested wheatgrass)

have been replaced by two subshrubs, broom snakeweed (*Gutierrezia sarothrae*) and fringed sagewort (*Artemisia frigida*), and several annual forb and annual grass species. Native perennial grasses and forbs are uncommon in this “go-back” field.

The dominant community types on slopes adjacent to the “go-back” field are ponderosa pine/bluebunch wheatgrass (*Pinus ponderosa/Agropyron spicatum*), burned ponderosa pine/bluebunch wheatgrass, and grassland dominated by western wheatgrass (*Agropyron smithii*) and needle-and-thread grass (*Stipa comata*).

Swales draining the broad ridge support a variety of vegetation community types including green needlegrass/western wheatgrass (*Stipa viridula/Agropyron smithii*), western snowberry/Kentucky bluegrass (*Symphoricarpos occidentalis/Poa pratensis*), silver sagebrush/green needlegrass (*Artemisia cana/Stipa viridula*), and burned ponderosa pine/western snowberry (*Pinus ponderosa/Symphoricarpos occidentalis*). The drainage north of the Generation Plant site, where the solid waste disposal site would be located, supports a shrub community dominated by common chokecherry (*Prunus virginiana*) where the drainage is deeply incised.

Four state-listed noxious weeds are present in the Generation Plant Study Area: spotted knapweed (*Centaurea maculosa*), Canada thistle (*Cirsium arvense*), field bindweed (*Convolvulus arvensis*), and houndstongue (*Cynoglossum officinale*). Spotted knapweed was not recorded during the 1991 baseline inventory for the Mine (Western Technology and Engineering, Inc. 1991) and apparently has become established within the past 10 years. Figure 3-4 depicts the extent of spotted knapweed observed during the field survey of the Generation Plant site. The major population is located at the east end of the “go-back” field extending to the north in burned areas that have been logged. Smaller populations are scattered throughout the Generation Plant Study Area.

Canada thistle is common throughout the Generation Plant Study Area, especially in burned pine types and drainage bottoms. Field bindweed is present in the “go-back” field but has not measurably spread into native community types. Houndstongue is present generally in small populations throughout the Generation Plant Study Area.

No federal or state-listed plant species of concern are known to occur within 10 miles of the Generation Plant Study Area (Montana Natural Heritage Program, 2002b), and no species of concern were identified during intensive surveys of the adjacent mine area or of the railroad and Transmission System Study Area. The only reported state listed plant species in Musselshell County, Poison suckleya (*Suckleya suckleyana*), was recorded in 1948, approximately 38 miles north of the Generation Plant Study Area (Montana Natural Heritage Program, 2002b). Poison suckleya is a wetland species and no potential habitat for this species occurs in the Generation Plant Study Area.

Figure 3-4 Vegetation

Table 3-9 Vegetation Community Types

Grassland	
Green needlegrass/Western wheatgrass	<i>Stipa viridula/Agropyron smithii</i>
Needle-and-thread/Western wheatgrass	<i>Stipa comata/Agropyron smithii</i>
Shrub/Grassland	
Silver sagebrush/Green needlegrass	<i>Artemisia cana/Stipa viridula</i>
Western snowberry/Silver sagebrush	<i>Symphoricarpos occidentalis/Artemisia cana</i>
Western snowberry/Kentucky bluegrass	<i>Symphoricarpos occidentalis/Poa pratensis</i>
Skunkbush sumac/Needle-and-thread	<i>Rhus aromatica/Stipa comata</i>
Ponderosa Pine Savannah and Forest	
Ponderosa pine/Bluebunch wheatgrass	<i>Pinus ponderosa/Agropyron spicatum</i>
Ponderosa pine/Green needlegrass	<i>Pinus ponderosa/Stipa viridula</i>
Ponderosa pine/Western snowberry	<i>Pinus ponderosa/Symphoricarpos occidentalis</i>
Burned Ponderosa Pine	
Burned Ponderosa pine/Bluebunch wheatgrass	Burned <i>Pinus ponderosa/ Agropyron spicatum</i>
Burned Ponderosa pine/Western snowberry	Burned <i>Pinus ponderosa/Symphoricarpos occidentalis</i>
Burned Ponderosa pine/Common chokecherry	Burned <i>Pinus ponderosa/ Prunus virginiana</i>
Agricultural Land	
Go-back Hay Meadow	<i>Gutierrezia sarothrae/Artemisia frigida</i>

Transmission System

It is proposed that the Transmission System would connect with the Broadview Substation west of the Generation Plant following the Bull Mountain coal railroad spur right-of-way. The railroad spur right-of-way is primarily located in uplands; however, several small drainages may be crossed. Small wetland/riparian areas may be associated with some of these ephemeral drainages. Other wetlands may be located along the corridor generally associated with springs, seeps, and intermittent streams. Wetlands provide watering points for wildlife and livestock and provide habitat diversity. Precipitation dependent wetland sites fluctuate annually, in a range from completely dry to wet, in direct response to seasonal moisture, temperature, and wind.

Vegetation communities along the railroad spur corridor are similar to vegetation communities represented at the Generation Plant site. No federal- or state-listed plant species of concern are known to occur in Musselshell County (Montana Natural Heritage Program, 2002b), and no species of concern were identified during intensive surveys of the adjacent mine area or of the railroad and Transmission System Study Area.

3.6 Wildlife Resources

3.6.1 Overview

The following discussion includes information extracted from the Supplemental EIS Support Document (Bull Mountain Development Company, LLC, 2002a), the Bull Mountains Mine FEIS (Montana Department of State Lands, 1992), and the Railroad Spur Checklist EA (DNRC, Trust Land Management Division, 2002).

Wildlife resources near the proposed Project site have been examined since mine-related studies began in the Bull Mountains in 1972. The Generation Plant site was included within mine-related aerial and vehicle survey study areas monitored regularly by various studies from 1972 through 1978, as well as Montana Fish, Wildlife and Parks (MFWP) game surveys. These studies were summarized in the draft and final environmental impact statements (DEIS and FEIS, respectively) for the Mine (MDSL, 1992a,b) and submitted to the DEQ. Wildlife monitoring for the Mine began again in 1993 and continued through 1996.

3.6.2 Inventory Methods

Geographic Information System (GIS) maps were created using survey control data including topography with contour intervals at two feet. USGS 7.5' topographic maps and aerial photography were obtained and analyzed to verify habitat types, and landscape features. On-site observation was used to verify conditions. The results of a field reconnaissance of the site conducted on January 11, 2002, and contacts with agencies regarding wildlife resources of the area were utilized in the analysis as well.

3.6.3 Inventory Results

Generation Plant

The proposed Generation Plant site is located on a small mesa at the top of the drainage divide that separates the Yellowstone and Musselshell River drainages. The Yellowstone River is located approximately 35 miles to the south while the Musselshell River flows approximately 15 miles to the north. The Generation Plant site is located in the southeast corner of Section 15, T6N, R26E on a flat ridge that separates the upper reaches of Halfbreed Creek and Rehder Creek.

For this analysis, vegetation types and communities identified in the vegetation section are considered synonymous with wildlife habitat types. Five broad vegetation types, comprising 13 vegetation communities, occur on the proposed Project site (see Table 3-9):

- Grassland (green needlegrass/western wheatgrass, needle-and-thread/western wheatgrass),
- Shrub/grassland (silver sagebrush/green needlegrass, western snowberry/silver sagebrush, western snowberry/Kentucky bluegrass, skunkbush sumac/needle-and-thread),
- Ponderosa pine savannah and forest (ponderosa pine/bluebunch wheatgrass, ponderosa pine/green needlegrass, ponderosa pine/western snowberry),

- Burned ponderosa pine (burned ponderosa pine/bluebunch wheatgrass, burned ponderosa pine/western snowberry, burned ponderosa pine/common chokecherry) and
- Agricultural land (go-back hay meadow).

These habitats are common and widespread within the Bull Mountains. No surface water bodies or aquatic habitat exists at the Generation Plant site.

The Bull Mountains surrounding the Generation Plant Study Area support a good diversity of wildlife: 36 mammals, 112 birds, 7 reptiles, and 5 amphibians have been recorded. Many of these species, particularly non-game species, could occur at least seasonally on or adjacent to the proposed Project site. Some species, such as those associated with wetlands, would not be expected to occur, or would occur only in very low numbers, due to the absence of their preferred habitats.

Five big game species are regularly present in the Bull Mountains. The most abundant big game species in the Bull Mountains is mule deer (*Odocoileus hemionus*), which are common and widespread. They are non-migratory and are found year round at or near the proposed Project site.

Elk (*Cervus elaphus*) are the second-most abundant big game species in the Bull Mountains. They are migratory and normally are found in higher elevations or more thickly forested habitat away from human activity. The elk herd in the Bull Mountains has been increasing in numbers in recent years. A complete count of elk in the Bull Mountains, made during the 2001–2002 winter, yielded several hundred animals compared to an estimate of about 100 made during the late 1970s. Despite this increase and the habitat changes resulting from the 1984 fires, elk seasonal distribution has not changed substantially. Portions of upper Rehder Creek are used as summer range; there is no defined winter range at the proposed Project (MDSL 1992a, b), although elk could occur in the area, particularly during mild winters. However, no elk or their evidence (such as tracks, hair, antler sheds, or pellets) was observed during the field reconnaissance of the site. Elk are seen regularly to the north, east, and southeast of the Generation Plant Study Area, but are observed comparatively infrequently within this area.

White-tailed deer (*Odocoileus virginianus*) are uncommon in the Bull Mountains and are seldom observed. The Generation Plant Study Area would be considered marginal pronghorn (*Antilocapra americana*) habitat, with occasional use from spring through autumn but not in winter (MDSL 1992a, b).

Mountain lions (*Puma concolor*) may be widespread in the Bull Mountains, but this secretive species is seldom observed and their numbers are unknown.

A wide variety of non-game mammals is present in the Bull Mountains, including 10 of the 15 species of bats recorded in Montana. Sightings or evidence of coyote (*Canis latrans*), bobcat (*Lynx rufus*), badger (*Taxidea taxus*), porcupine (*Erethizon dorsatum*), Richardson's ground squirrel (*Spermophilus richardsonii*), northern pocket gopher (*Thomomys talpoides*), and mountain cottontail (*Sylvilagus audubonii*) were recorded on the proposed Project site during the field reconnaissance. All these species are considered common in the Bull Mountains.

Richardson's ground squirrels were present in comparatively small, somewhat isolated colonies near the Project site before the 1984 fires. Since the fires, this species has proliferated throughout

the burned areas and adjacent grassland habitats (Butts, 1997). Its mounds were abundant over much of the proposed Project site.

The wild turkey (*Meleagris gallopavo*), a non-native but widespread and common species, is the most likely upland game bird to occur on the Project site, although no evidence of wild turkeys was observed during the field reconnaissance. Sharp-tailed grouse (*Tympanuchus phasianellus*) is a native species normally associated with shrublands and grasslands. A display site (lek) was located within one mile southeast of the proposed Project, but this lek has been inactive since the mid-1990s (Butts, 1997). Other upland game birds, including ring-necked pheasant (*Phasianus colchicus*), gray partridge (*Perdix perdix*), and sage grouse (*Centrocercus urophasianus*), are uncommon in the Bull Mountains, and would not be expected to occur in large numbers in the habitats of the proposed Project.

Fourteen species of raptors have been observed within the Bull Mountains. The proposed Project site supports a limited variety of potential nest sites for raptors. Live and dead standing ponderosa pine trees are the most common nest site in the area; one stick nest, probably constructed by red-tailed hawks (*Buteo jamaicensis*), was found in a live ponderosa pine about 350 feet southeast of the proposed southeast plant site boundary fence during the field reconnaissance. An unidentified owl, probably either a great horned owl (*Bubo virginianus*) or long-eared owl (*Asio otus*), was flushed from a stand of live ponderosa pine trees within the proposed Project site, but no nest was found in this area. Vertical vegetation structure for ground nesting species such as the northern harrier (*Circus cyaneus*) is very limited. Ground squirrel colonies could provide nest sites for subterranean-nesting species such as the burrowing owl (*Athene cunicularia*); no evidence of this species (such as droppings, feathers, or casts) was observed during the field reconnaissance. No cliffs, banks, or rock outcrops suitable for cliff-nesting raptors were present on or within 0.25 mile of the proposed Project.

Species of Concern

For this discussion, “species of concern” are considered those species so identified by the Montana Natural Heritage Program, (2002a) and include species that are federally listed or proposed as endangered or threatened. The Project and surrounding lands within 1.0 mile are not known to support endemic populations of any wildlife species of concern (Montana Natural Heritage Program, 2002a).

No amphibians and only one reptile are represented on the list of species of concern for Musselshell County (Montana Natural Heritage Program, 2002a). The Musselshell River is considered habitat for the spiny softshell turtle (*Trionyx spiniferus*). The spiny softshell is found along large rivers and their sandy banks, up to 50 meters away from the banks (Montana Natural Heritage Program, 2002a). The spiny softshell has been recorded eight times since 1971 in the Missouri River Drainage, but only one of these sightings was from the Musselshell River. Given the long distance down Halfbreed Creek from the proposed Project to the Musselshell River, and since the spiny softshell is not known to occur in Halfbreed Creek, it is highly unlikely that this species would be found at or near the proposed Generation Plant site.

Four avian species of concern have been recorded in Musselshell County (Montana Natural Heritage Program, 2002a). The bald eagle (*Haliaeetus leucocephalus*), federally listed as threatened, occurs during migration and as a winter resident of the Bull Mountains but is not known to nest anywhere near the proposed Project. The ferruginous hawk (*Buteo regalis*) could

nest in trees or on cliffs, outcrops, and bluffs in the Bull Mountains, but has never been observed nesting near the Mine, including the proposed Project site. The peregrine falcon (*Falco peregrinus*) nests on cliffs comparatively near large rivers or lakes, but appropriate nesting requirements are not available at or near the proposed Project site. The mountain plover (*Charadrius montanus*), federally proposed as threatened, could inhabit grasslands with very little vegetative height, such as prairie dog or ground squirrel colonies. Although ground squirrel colonies are present at and near the proposed Project site, this species is not known from the general area.

Two mammals are included on the list of species of concern from Musselshell County (Montana Natural Heritage Program, 2002a). Black-tailed prairie dogs (*Cynomys ludovicianus*) are a colonial species that are usually found in grassland habitat; no colonies are known to occur at or near the proposed Project site. The Townsend's big-eared bat (*Corynorhinus townsendii*) has been observed near the Mine in the past, and could forage at or near the proposed Project site, which does not have suitable habitat for maternity colonies or hibernacula for this species.

Transmission System

It is proposed that the Transmission System would connect the Generation Plant with the Broadview Substation to the west of the Generation Plant site and would follow the Bull Mountain coal railroad spur right-of-way. The railroad spur right-of-way is primarily located in uplands and non-irrigated agricultural lands; however, the eastern portion is located in ponderosa pine (*Pinus ponderosa*) forest. The Transmission System would not cross or travel adjacent to any perennial stream systems.

Vegetation types and communities in the Transmission System Study Area become relatively homogenous after the initial nine miles. The initial nine miles of the Transmission System (from the Generation Plant) are in similar vegetation types and communities as the Generation Plant site. The remaining 20 miles of Transmission System Study Area traverse open low scrub habitat and non-irrigated agricultural lands.

Big game species identified in the Generation Plant portion of this section probably would occur in the initial nine miles of the Transmission System. Additionally, pronghorn probably would occur in the lower reaches of the Transmission System. Sharp-tailed grouse are known in the area, and there probably are leks along the Transmission System Study Area. However, none have been recorded (Newell, 2002).

Avian species identified in the Generation Plant portion of this section probably occur in the initial nine miles of the Transmission System. Raptors may be found in the lower reaches due to the presence of grassland habitat that may provide additional foraging ground and possible nesting opportunities for ground nesting species.

3.7 Fisheries and Aquatic Resources

3.7.1 Overview

The following discussion includes information extracted from the Supplemental EIS Support Document (Bull Mountain Development Company, LLC, 2002a), the Bull Mountains Mine FEIS

(Montana Department of State Lands, 1992a), and the Railroad Spur Checklist EA (DNRC, Trust Land Management Division, 2002).

Fisheries resources near the proposed Project site have been examined since mine-related studies began in the Bull Mountains in 1972. The Generation Plant site was included within mine-related aerial and vehicle survey study areas monitored regularly by various studies from 1972 through 1978, as well as MFWP game surveys. These studies were summarized in the draft and final environmental impact statements (DEIS and FEIS, respectively) for the Mine (MDSL 1992a,b) and submitted to the DEQ. Wildlife monitoring for the Mine began again in 1993 and continued through 1996.

3.7.2 Inventory Methods

GIS maps were created using survey control data including topography with contour intervals at two feet. USGS 7.5' topographic maps and aerial photography were obtained and analyzed to verify habitat types, and landscape features. On-site observation was used to verify conditions. The results of a field reconnaissance of the site conducted on January 11, 2002, and contacts with agencies regarding wildlife resources of the area were utilized in the analysis as well.

3.7.3 Inventory Results

Generation Plant

The proposed Generation Plant site is located on a small mesa at the top of the drainage divide that separates the Yellowstone and Musselshell River drainages. The Yellowstone River is located approximately 35 miles to the south while the Musselshell River flows approximately 15 miles to the north. The Generation Plant site is located in the SE corner of Section 15, T6N, R26E on a flat ridge that separates the upper reaches of Halfbreed Creek and Rehder Creek.

There are no standing or flowing waters on the proposed Project site. Drainage to the west and south from the proposed plant is into ephemeral tributaries approximately 0.5 mile to Halfbreed Creek, which flows over 16 miles north to its confluence with the Musselshell River (MFWP 2001). According to USGS topographic maps, Halfbreed Creek is intermittent from its headwaters west of the proposed plant site downstream about 3.5 miles to its confluence with Rehder Creek, and it is perennial from Rehder Creek to its confluence with the Musselshell River.

Species of Concern

Only one fish species of concern, the northern redbelly X finescale dace (*Phoxinus eos X Phoxinus neogaeus*), has been identified for Musselshell County (Montana Natural Heritage Program, 2002a). This hybrid is a unique species in that nearly all specimens collected are female, they are usually found in the presence of only one parent species, and they are apparently the products of clonal or parthenogenetic reproduction. Northern redbelly dace are common in Montana but finescale dace have never been collected in the state (Holton and Johnson 1996). Neither the northern redbelly dace nor the hybrid has been recorded from Halfbreed Creek (MFWP 2001), and it seems unlikely that either species would be present at or near the proposed Project.

Recreational Fishery

Drainage to the east and north from the Generation Plant site is about 1.5 to 2 miles down ephemeral tributaries to Rehder Creek, which is an intermittent tributary of Halfbreed Creek. No angling-use data were available for Halfbreed Creek and the MFWP (2001) has not sampled Rehder Creek, so, its fishery value is unknown.

MFWP (2001) reported that ingress is limited on Halfbreed Creek, but that some fishing is occurs there. Halfbreed Creek is managed as a trout stream, with a moderate to low Fisheries Resource Value (4 on a scale of 2 to 5, with 5 being lowest value). Given the ephemeral-to-intermittent nature of Halfbreed Creek upstream from Rehder Creek, it is reasonable to assume that fishing (and any game fish) in Halfbreed Creek occurs downstream from Rehder Creek and that there is little or no recreational fishery near the Generation Plant site.

Transmission System

It is proposed that the Transmission System would connect the Generation Plant at Roundup with the Broadview Substation to the west of the Generation Plant site and would follow the Bull Mountain coal railroad spur right-of-way. The Transmission System would not cross nor travel adjacent to any perennial stream systems.

3.8 Cultural Resources

3.8.1 Overview

Cultural resources are sites, buildings, structures, districts, landscapes, or objects that are important to a culture or community for scientific, traditional, religious, or other reasons. Cultural resources can be divided into three major categories: archaeological resources, architectural resources, and Traditional Cultural Properties.

Archaeological resources are locations where human activity has measurably altered the earth or left deposits of physical remains. In Montana, the term "prehistoric" refers to archaeological resources associated with Native Americans, particularly before contact with Euro Americans. The term is also generally understood to mean cultural resources that predate the use of written records. Prehistoric archaeological resources in Montana can range from isolated stone tools to stone circles, rock cairns, village sites, and petroglyphs. The term "historic" is generally meant to include any cultural resource that postdates Euro American contact with Native Americans. Historic archaeological resources include campsites, roads, fences, trash dumps, abandoned mines, and a variety of other features.

Architectural resources are standing buildings, dams, bridges, canals, and other structures. In Montana, architectural resources are all historic.

Traditional Cultural Properties (TCPs) are resources associated with cultural practices and beliefs of a living community that are rooted in its history and are important in maintaining the continuing cultural identity of the community. In Montana, these are usually associated with modern Native Americans. Native American TCPs may include certain archaeological resources, such as cairns and petroglyphs; locations of important events; battlefields; sacred sites; and traditional hunting and gathering areas.

For this EIS, only significant cultural resources warrant consideration with regard to potential impacts. Significant cultural resources are generally those that have been determined eligible for inclusion in the National Register of Historic Places (National Register) or that have been recommended as being eligible. The identification of cultural resources and the evaluation of their significance are performed through procedures specified in Section 106 of the National Historic Preservation Act (NHPA) and its implementing regulations (36 CFR part 800). Evaluation is based on criteria for National Register eligibility (36 CFR 60.4) and on consultation with the State Historic Preservation Officer (SHPO) at the Montana Historical Society (MHS). As a rule, cultural resources must be at least 50 years old to be eligible for the National Register. For this EIS, cultural resources whose National Register eligibility has not been evaluated are assumed potentially eligible. Certain categories of Native American TCPs, such as sacred geographic features, may not meet any National Register eligibility criteria, but may still be significant to a particular tribe.

3.8.2 Inventory Methods

For the Project EIS, the affected environment for cultural resources includes both the area of potential ground disturbance and the area of potential changes in visual setting.

The area of potential ground disturbance includes the locations of the proposed Generation Plant, access roads, Transmission System, conveyor belt, and other facilities.

The area of potential changes in visual setting was not addressed in the Supplemental EIS Support Document (Bull Mountain Development Company, LLC, 2002a). Under Section 106 of the NHPA, adverse effects to cultural resources can include changes in visual setting if the visual characteristics of the resource and its surroundings contribute to its National Register eligibility. In assessing potential visual effects, it is common to select a radius around the proposed action within which visual impacts on cultural resources would be assessed. The Montana State Historic Preservation Office (SHPO) does not have a preferred radius for assessing visual effects (J. Warhank, 2002). However, SHPOs in other states use radii ranging from 0.5 mile to 2.0 miles when assessing the effects of tall (100 to 300-foot) structures such as cellular communications towers. Because the chimneys for the proposed Generation Plant would be 574-foot tall, it was decided that for this EIS the area of potential changes in visual setting would be defined as being within 3.0 miles of the chimneys. This is considered the maximum distance from which the chimneys could potentially degrade the visual setting of cultural resources that are visually sensitive.

The cultural resource data compiled for this analysis resulted from:

- Review of the National Register database for Musselshell and Yellowstone counties;
- File searches by the Cultural Resource Manager of the MHS on November 6, 2001 (Pouley, 2002), February 8, 2002, and October 8, 2002;
- Cultural resource surveys of the proposed plant site (Bull Mountain Development Company, LLC., 2002a; Pouley, 2002), the Mine (MDL, 1992; Rood, 1990); and a proposed rail corridor (Metcalf, 2002; Pool, 1991; Tetra Tech, 1991);
- Consultation or attempted consultation with Native American tribes (Pouley 2002; Tetra Tech, 1991); and

- A brief cultural resource reconnaissance of the Generation Plant Study Area in October 2002.

On October 8, 2002, the Cultural Resources Manager for the MHS performed a file search for all lands within 3.0 miles of the chimneys. Rather than performing an intensive inventory of cultural resources within this large circle (28 square miles), two cultural resource specialists performed a brief field reconnaissance by driving along all accessible roads in the area. They determined which previously recorded historic structures still existed (several had burned during brush fires), identified other properties that appeared to be more than 45 years old, and assessed which properties were likely to contain features or characteristics that were visually sensitive, such as standing structures, petroglyphs, or potential TCPs. Archaeological sites, such as prehistoric lithic scatters and historic trash dumps, were not considered visually sensitive because their National Register eligibility would more likely be related to their information potential rather than to their visual setting.

In 1990, tribal and traditional representatives of the Crow, Northern Cheyenne, Atsina or Gros Ventre, Assiniboine, and Shoshone were contacted regarding potentially sensitive resources along the proposed railroad right-of-way through the Bull Mountains. This consultation included visits to the area by Tribal representatives (R. Bohman, 2002; Tetra Tech 1991). On January 11, 2002, a letter from the proponent's consultant was sent to the Crow Tribal Cultural representative describing the Project and the results of the survey near the proposed generating plant. Four follow-up phone calls were made the same month, but the Crow Tribe did not respond.

DEQ is in the process of contacting Native American organizations regarding the proposed action. Previously recorded cultural resources in the Project vicinity include some that may be of special concern to Native Americans as potential TCPs.

3.8.3 Inventory Results

Generation Plant

Within three miles of the proposed chimneys, there are 41 previously recorded cultural resources. These include 26 prehistoric lithic scatters, four petroglyph sites, two rockshelters, one rock cairn, six historic trash dumps, three homestead or farmstead sites, one coalmine, and three other historic sites. Seven of the prehistoric sites (i.e., petroglyph sites, rockshelters, and the cairn) may also qualify as TCPs, although Tribal representatives have not confirmed this. The 41 cultural resources do not include isolated artifacts (e.g., chipped stone flakes, tin cans).

The brief reconnaissance performed in October 2002 resulted in the identification of 10 other possible cultural resources within a 3-mile radius. Each of these was historic, and all were either historic structures or the remains of structures. Because of the brief duration of the reconnaissance, these resources were not fully documented on Montana Cultural Resource Information System (CRIS) forms and were not evaluated according to National Register criteria.

Transmission System

According to Metcalf (2002), 15 cultural resources have been identified within or next to the proposed rail corridor. This corridor has been proposed as the route for a Transmission System from the generation facility. The resources along the Transmission System Study Area include eight lithic scatters, two rock cairns, three historic trash scatters, one historic farmstead, and one mine. The two cairns may also be TCPs. One the cairns is also within the 3-mile radius around the proposed generating site.

In summary, 65 cultural resources have been identified within the area of potential effect for the Project.

3.9 Visual Resources

3.9.1 Overview

This chapter describes the existing visual resources within the Generation Plant and Transmission System study areas. This chapter also describes the type and quantity of sensitive viewers located nearby both Project facilities. For issues associated with visibility of atmospheric haze in Class I PSD areas, see section 3.2, Air Resources.

3.9.2 Inventory Methods

There are no formal guidelines for managing visual resources on private, state, or county-owned lands found within the vicinity of the Project site. Therefore, the visual inventory was conducted using principles derived from the Bureau of Land Management (BLM) Visual Resource Management (VRM) System 8400 series manuals and modified to accommodate rural, non-BLM managed landscapes. This method provided a consistent inventory process across the Study Area for public and private lands.

A 1.5-mile wide plan area (0.75 mile each side of the Transmission System Study Area centerline) was inventoried to document existing visual resources and sensitive viewers adjacent the Transmission System Study Area. A 5-mile radius from the center of the Generation Plant was inventoried to document existing visual resources and sensitive viewers. The study process included analysis of recent topographic maps/aerial photography, Musselshell County rural addressing data, contacts with Yellowstone and Musselshell County, field reconnaissance surveys and review of existing literature sources. The result is a consistently inventoried database used to assess visual impacts (see Chapter 4, Environmental Impacts) for the Transmission System and the Generation Plant. The inventory consists of the following three major components:

- Regional Setting/Landscape Character Type Inventory
- Viewer Sensitivity Inventory
- Visibility from Sensitive Viewpoints

The following subsections define visual resource terminology and describe the specific inventory methods used for gathering and completing the visual resource inventory.

Regional Setting/Landscape Character Type Inventory

Analysis of the scenic values of the landscape began with an examination of the region's physiography contained within Fenneman's *Physiography of the Western United States* (1931). Related literature, interviews with county personnel, and interpretation of recent aerial photography were used to determine the landscape character types for areas crossed by the Transmission System Study Area as well as areas contained within the Generation Plant Study Area.

Physiographic provinces are further divided into sections. These classifications describe the visual character of the landscape at a regional scale. Landscape character types are landscape units of greater detail refined from the regional physiographic province and section classifications. Dominant landform features (e.g., mountains, canyons) typically define landscape character types.

Beyond basic land formations (i.e., vegetation cover, soil color and any untypical features, such as an abundance of rock outcroppings or unique water features) other landscape features were also observed and noted during field visits.

Sensitivity Inventory

The Viewer Sensitivity Inventory documents those areas where viewers could be concerned about changes to the landscape. Three components comprise the viewer sensitivity inventory: views from sensitive viewpoints, visual sensitivity, and seen areas/visibility thresholds.

Views from Sensitive Viewpoints

Potentially sensitive viewpoints were identified and inventoried within the Generation Plant Study Area and Transmission System Study Area. Identification of these viewpoints included recent aerial photos, discussions with county officials, review of land use data, Musselshell County rural addressing data, and field reconnaissance. The inventory includes the following types of viewpoints:

- Residences, including single-family rural residential dwellings
- Travel Routes, including U.S. Highways.
- Cultural Sites, including visually sensitive areas where changes to the landscape could impact the integrity of a cultural site.

Visual Sensitivity

Visual sensitivity is a measure of viewer concern for change to the landscape. Visual sensitivity is evaluated and documented based on public concerns, discussions with county officials, and review of existing agency information. The evaluation borrows from the methods outlined on the BLM VRM 8400 System modified to address privately owned rural-related viewpoints. The visual sensitivity criteria used for the Project's aesthetics impact analysis are shown on Table 3-10.

Table 3-10 Visual Sensitivity Criteria

Criteria	High	Moderate	Low
Use Volume	High level of use	Moderate level of use	Low level of use
User Attitude	High expectations for maintaining scenic quality/visual integrity (i.e. residences)	Users are concerned for scenic quality/visual integrity but are not the primary focus of their experiences (i.e. dispersed recreation areas and general travel routes)	Areas where the public has low expectations for maintaining scenic integrity. Generally commercial or industrial areas where human caused modifications already exist in the landscape
Duration of View	Fixed or contiguous views (e.g. residences)	Intermediate views (e.g., open highway views)	Brief or intermittent views (e.g., highway views in rolling landscapes)

Table 3-11 illustrates the combinations of the above criteria and the resulting visual sensitivity level. Results of the visual sensitivity were reviewed, refined, and carried forward into the visual impacts analysis (refer to Chapter 4—Environmental Impacts).

Table 3-11 Visual Sensitivity Matrix

Use Volume	User Attitude	Duration of View	Total Visual Sensitivity Level
High	High	Long	High
Moderate	High	Moderate	High
Low	High	Moderate	High
High	Low	Short	Moderate
High	Moderate	Moderate	Moderate
Moderate	Moderate	Moderate	Moderate
Moderate	Low	Moderate	Moderate
Low	Moderate	Short	Low
Low	Low	Short	Low

Seen Area/Visibility Thresholds

Visibility thresholds are established zones of visual perception. Essentially, form, line, color, and textures are perceived differently with increasing distance from a viewpoint (Jones and Jones, 1976). With an increase in distance, changes in the landscape become less obvious and perception of detail is diminished. Elements of form and line become more dominant than color or texture.

The visibility thresholds for the Generation Plant Study Area are defined as follows:

- **High Visibility Threshold (0 to ½ mile):** The zone where fine details are obvious. Texture and color are vivid and clear. New features such as heavy industrial land use would dominate the view.
- **Moderate Visibility Threshold (½ to 1 mile):** This is the threshold where changes in the landscape might be viewed in less detail. Form and other aesthetic qualities of vegetation are typically perceived in this zone. Fine details diminish. Overall form is vivid and clear.
- **Low Visibility Threshold (1 to 5 miles):** This zone is where details of foliage and textures cease to be perceptible and features begin to appear as outlines or patterns. Visible form and line are seen with less clarity.
- **Seldom Seen Visibility Threshold (beyond 5 miles):** Those areas of the landscape where elements are represented as rough outlines. Form and line are barely visible. Colors are diminished in most cases due to atmospheric haze and appear washed out or muted.

These distance zones were established based on the nature and appearance of the Project where new 574-foot-tall chimneys and 250-foot-tall boiler buildings would occur where none currently exist.

The visibility thresholds for the Transmission System are defined as follows:

- **High to Moderate Visibility Threshold (0 to ¾ mile):** This is the threshold where changes in the landscape might be viewed in less detail. Form and other aesthetic qualities of vegetation are typically perceived in this zone. Fine details diminish. Overall form is vivid and clear. New features such as the proposed Transmission System would be noticeable in the view.

This distance zone was selected based on the nature and appearance of the Project where new Transmission Systems would occur where none currently exist (with the exception near Broadview Substation). This distance zone also assumes the view of a railroad right-of-way immediately adjacent the Transmission System facilities. Viewpoints located beyond ¾ mile were not inventoried due to the nature and appearance of Project facilities along the Transmission System Study Area.

3.9.3 Inventory Results

Generation Plant

Regional Setting/Landscape Character Types

Regional Setting

Overall, the Generation Plant Study Area contains visual resources such as Signal Mountain and The Bull Mountains. Foothills, ephemeral drainages, riparian vegetation, annual grasslands, and large expanses of ponderosa pine influence the natural visual setting. Human built features that influence the visual setting found in the Generation Plant Study Area include: U.S. Highway 87, dispersed rural residential housing and agricultural fields along with grazing areas. No BLM or U.S. Forest Service (FS) lands occur within or near the Generation Plant Study Area, see Figure 3-5.

The visual characteristics of the Generation Plant Study Area are predominantly rural, with a few notable exceptions. The area is characterized by rolling hills and gently sloping valleys, punctuated occasionally by dramatic rock outcroppings. Some of the hills are vegetated with ponderosa pine, but most of the vegetation consists of grasses and low-growing shrubs. A severe fire burned part of the area in 1984, and some of the hills are covered with dead trees. There are no designated landmarks in the area, but Signal Mountain, a sandstone outcropping that rises about 80 feet above the surrounding land, could be considered a local landmark.

U.S. Route 87, Old Divide Road, and numerous power distribution lines cross the Generation Study Area. Scattered houses and house trailers are visible in most parts of the area. In some of the subdivided parts of Sections 22 and 23, south of the Project site, houses and trailers are numerous enough to give the impression of a continuous residential development. Storage buildings and junked vehicles also are noticeable in some parts of the area. The PM Coal Mine has introduced industrial activities into the area.

Overall, the visual and aesthetic elements of the Generation Plant Study Area are typical for this part of Montana. The proposed facilities would be located in areas where the natural aesthetic features are common to their physiographic region. Although there are no features of critical or unique scenic significance, there are some features that could be considered locally sensitive.

Physiography/Landscape Character Types

The Generation Plant Study Area is located within the Great Plains province, within the unglaciated portion of the Missouri Plateau. "The Missouri Plateau is characterized by isolated mountains scattered throughout the western third of the plateau. These mountains rise 500-1500 feet above the surrounding plains" (Fenneman, 1931). The Bull Mountains are one range that occurs within this portion of the Missouri Plateau.

Viewer Sensitivity Inventory

High to moderate sensitivity viewpoints near the Generation Plant Study Area are shown in Figure 3-5 with the exception of cultural sites. Moderate sensitivity viewpoints include U.S. Route 87, which connects Billings with the city of Roundup.

Figure 3-5 Sensitive Views

U.S. Route 87 is a moderate sensitivity viewpoint due to the high use volume, moderate to low duration of view and moderate user attitude. High sensitivity viewpoints include 280 single-family residences within five miles of the Project site (Musselshell County, 2002) and eight cultural sites within three miles of the Project site determined to be visually sensitive to potential changes to their site integrity, see Section 3.8, Cultural Resources. All residences were considered high sensitivity due to the long duration of fixed views, high user attitude, and comparatively moderate use volume (residential density) found within the Generation Plant Study Area.

Visibility from Sensitive Viewpoints

The Viewpoints identified within the Generation Plant Study Area have views that vary from expansive to limited, depending on local topography and the presence or absence of surrounding vegetation. Specifically, one residence has views of the Generation Plant Study Area within the high visibility threshold. Seven residences have views within the moderate visibility threshold.

Ten residences have views of the Generation Plant Study Area within the low visibility threshold, and motorists traveling U.S. Route 87 have views within the moderate visibility threshold (See Figure 3-5).

Transmission System

Regional Setting/Landscape Character Types

Regional Setting

The proposed 28.2-mile Transmission System would run from the east end of the proposed Generation Plant in a southwesterly direction to the Broadview Substation, about two miles south of Broadview, see Figure 2-12. The Transmission System right-of-way varies from 225 to 250 feet wide and traverses lands ranging from Ponderosa Pine forests and grassy valleys with some small, steep-sided canyons on the east end, to gently rolling, open hay and wheat fields (mileposts [MP] 9-20) and lowland on the west end near Broadview Substation (MP 20-28). The east end (MP 0-9) is a mix of some unique visual features with some common to the region, while the west end (MP 9-28) is composed of features that are subtle, with little variety, and common to the region.

State Route 281, Majerus Road, Twenty One Mile Road, and numerous power transmission lines cross the Transmission System Study Area. Scattered houses and house trailers are visible in most parts of the area. Storage buildings and agricultural structures are also noticeable in some parts of the area. Two existing 500kV transmission lines are visible from residences near Twenty One Mile Road, see Figure 2-11. One 12kV distribution line follows Majerus Road and State Route 281 paralleling the proposed Transmission System right-of-way in many places.

Overall, the visual and aesthetic elements of the Transmission System Study Area are typical for this part of Montana. The proposed facilities would be located in areas where the natural aesthetic features are common to their physiographic region. Although there are no features of critical or unique scenic significance, some features that could be considered locally sensitive are located from MP 0-9.

Physiography/Landscape Character Types

The Transmission System Study Area is located within the Great Plains province, within the unglaciated portion of the Missouri Plateau. Fenneman (1931) describes the area containing Hay Basin and Comanche Flat as Interstream Uplands. “The rolling, terrace-like plains here described are the dominant elements of the topography. Erosion has affected them to various degrees, broad valleys sometime connecting higher with lower levels, obscuring locally the real design. Unconsumed remnants rise above all levels.”

“There is a good deal of very rough country. Not only in the breaks along the Missouri and Yellowstone is there deep and thorough dissection, in places typical badlands, but in the larger interstream tracts ridges rise in places 500-1,500 feet above the valley bottoms, often with bold cliffs and picturesque tower and pinnacles, especially where the eminences are capped by sandstone” (Fenneman, 1931).

Viewer Sensitivity Inventory

Twenty-five residences were found within the 1.5 mile wide Transmission System Study Area. See Table 3-12 for their locations.

Table 3-12 Transmission System Viewer Inventory

Number of Residences	Section of Transmission System
1	MP 2-3
7	MP 5-10
4	MP 13-14
7	MP 17-19
5	MP 22-25
1	MP 27-28

All residences within the Transmission System Study Area were considered high sensitivity due to the long duration of fixed views, high user attitude, and comparatively low use volume (residential density) found within the Transmission System Study Area. The roads discussed in “Transmission System, Regional Setting” (with the exception of U.S. Route 87), were considered to have low viewer sensitivity due to the low user attitude, low use volume, and short duration of view.

Visibility from Sensitive Viewpoints

Residences have limited views of the proposed Transmission System Study Area within the Bull Mountains (MP 0-9) where local topography varies widely and Ponderosa Pine forests restrict expansive views. Residences have expansive views of the proposed Transmission System Study Area where seasonal agricultural crops and flat to gently rolling terrain occur along MP 9-28.

Public policies pertinent to Visual Resources

The Yellowstone County Comprehensive Plan states it is “the goal of Yellowstone County to protect scenic and visual resources throughout the County” (Yellowstone County, 1990). The policy states—“consider development impacts on scenic and visual resources of Yellowstone County.” The methods for achieving visual resource protection or consideration have not been implemented at this time (Beaudry, 2002). Methods proposed for scenic and visual resource protection by Yellowstone County include:

- Establish standards for the identification of scenic and visual resources
- Identify and map scenic and visual resources
- Develop preservation techniques for scenic and visual resources

The proposed Transmission System would traverse Yellowstone County from milepost 14.3 to milepost 28. Musselshell County does not have policies specific to the protection of visual resources (Intermountain Planners, 1973). The proposed Transmission System would occur within the existing right-of-way of the railroad spur already granted across State Trust lands (see Section 3.11, Land Use).

3.10 Noise

This section describes the terminology and the criteria used for the noise impact analysis of the Project. The noise study area included noise-sensitive receptors within approximately 1.5 miles of the proposed Generation Plant. This section also includes information extracted from the following documents: Supplemental EIS Support Document (Bull Mountain Development Company, LLC, 2002a), Bull Mountains Mine FEIS (Montana Department of State Lands, 1992b).

3.10.1 Overview

The word “noise” carries the meaning of *unwanted sound*. This interpretation implies a value judgment of the sound, which in turn generally implies the response of a person to a noise environment. Noise can affect the human environment by interfering with speech, interfering with sleep, causing hearing loss, and causing physical or mental stress. Since a person’s response to noise is subjective, it can vary from person to person.

Sound power is expressed in terms of a logarithmic ratio due to the tremendous range of power levels. This logarithmic power ratio has been designated the Bel in honor of Alexander Graham Bell. For practical purposes, a unit, which is one-tenth of a Bel and called a decibel or dB, is used. The level expressed in decibels (dB) always implies a reference quantity (Lord, et al., 1997) The A-weighted sound level has found much use in noise evaluation, since it correlates reasonably well with hearing-damage risk in industry and with subjective annoyance for a wide category of industrial, transportation, and community noises. For example, noise limits are specified in A-weighted (dBA) sound levels in the Occupational Safety and Health Act (OSHA). Humans typically have reduced hearing sensitivity at low frequencies compared with their response at high frequencies, and the A-weighting of noise levels closely correlates to the frequency response of normal human hearing (Elliot, et al., 1997).

Traveling from a noise source to a receptor in an outdoor environment, noise levels decrease with increasing distance between the source and receptor. Noise levels typically decrease by approximately six dBA every time the distance between the source and receptor is doubled depending on the characteristics of the source and the conditions over the path that the noise travels. The reduction in noise levels can be increased if a barrier, such as a man-made wall, a building, or natural topography, is located between the source and receptor.

The ambient noise at a receptor location in a given environment is the all-encompassing sound associated with that environment and is due to the combination of noise sources from many directions, near and far, including the noise source of interest.

For environmental noise studies, ambient noise levels are typically described using A-weighted equivalent noise levels, L_{eq} , during a certain period. The equivalent noise level is defined as the single steady-state noise level that has the same acoustical energy as the actual, time-varying noise signal during the same period. The purpose of L_{eq} is to provide a single number measure of time-varying noise for a predetermined duration of time.

The day-night average noise level, L_{dn} , is a single number descriptor that represents the constantly varying sound level during a continuous 24-hour period. The L_{dn} is typically calculated using 24 consecutive one-hour L_{eq} noise levels. The L_{dn} includes a 10 dBA penalty that is added to noises that occur during the nighttime hours between 10:00 p.m. and 7:00 a.m. to account for people's higher sensitivity to noise at night, when the background noise level is typically low.

An n^{th} percentile-exceeded noise level, L_n , indicates the single noise level that is equal or exceeded for "n" percent of a certain period. For example, an L_{10} noise level indicates the level that was exceeded during 10 percent of a measurement period, and the L_{90} noise level indicates the level that was exceeded during 90 percent of a measurement period. The L_{10} noise level is influenced by discrete events of short duration and high noise levels that occur during a period. The L_{90} noise level typically is considered the residual ambient noise level, and normally does not include the influence of discrete noises.

3.10.1 Noise Level Criteria

Noise Ordinances and Guidelines

There are no state, county, or local noise ordinances or laws to limit to noise created by industrial facilities (State of Montana, 1999, Musselshell County, 2002).

The Federal government has developed guidelines to determine when an increase in noise levels would cause an adverse impact. The U.S. Environmental Protection Agency (EPA) recommends that outdoor L_{dn} values at residences not exceed 55 dBA in order to protect the public health and welfare with an adequate margin of safety (EPA, 1974). Although the EPA guideline is not an enforceable regulation, it has been commonly accepted as a target to prevent significant impacts at residences.

Perception of Increased Noise

Noise impacts to people can be determined by evaluating the increase that a new noise source would have on the existing noise levels at a receptor location, such as a residence, church,

school, or park. Table 3-13 indicates the relationship between changes in noise levels and perception of the change (Egan, 1988).

Table 3-13 Changes in Noise Levels Versus Apparent Changes in Loudness

Increase in Sound Level (dBA)	Apparent Change in Loudness
1	Imperceptible
3	Barely audible (i.e., barely noticeable)
6	Clearly audible (i.e., clearly noticeable)
10	New noise appears to be twice as loud as the original
20	New noise appears to be four times as loud as the original

In general, the higher a new noise source is above the existing ambient noise level at a receptor location, the more noticeable the new source would be. Noise impacts are typically considered adverse if the noise levels due to a new noise source exceed the existing ambient levels by 10 dBA or greater.

3.10.3 Noise Inventory Results

Generation Plant

Existing Ambient Noise Levels

To help determine the long-term impact of the noise created by the Project on people, noise-sensitive receptors were identified within approximately one mile of the Generation Plant site. Receptor locations were identified using a map of residences Figure 3-6 and site observations. Residences, a church, and a church retreat facility are located within 1.5 miles (7,920 feet) to the northwest, south, and southeast of the proposed Generation Plant (Figure 3-6). The nearby noise-sensitive receptors are listed in Table 3-14.

Table 3-14 Noise-Sensitive Receptors

Receptor Identifier ¹	Description of Noise-Sensitive Receptor(s)	Approximate Distance and Direction from Power Plant	Approximate Distance and Direction from Coal Piles	Approximate Distance and Direction from U.S. 87
	Represents the nearest residence, Shining Mountain Christian Ranch, and Bull Mountains Community Church.	2,000 feet, south-southeast	1,500 feet, south-southwest	3,700 feet, east
	Residence.	4,300 feet, east-southeast	2,900 feet, east-southeast	6,900 feet, east-southeast

Receptor Identifier ¹	Description of Noise-Sensitive Receptor(s)	Approximate Distance and Direction from Power Plant	Approximate Distance and Direction from Coal Piles	Approximate Distance and Direction from U.S. 87
	Represents six (6) residences located near Cole Road.	5,000 feet, south	5,000 feet, southwest	1,000 feet, east
	Represents 12 residences near intersection of Old Divide Road and Fattig Creek Road. ²	7,400 feet, southeast	6,000 feet, southeast	8,500 feet, east
	Represents five residences near intersection of U.S. Route 87 and Big Clearing Road. ³	5,000 feet, northwest	6,000 feet, northwest	2,900 feet, east

Notes:

1. See Figure 3-6 for receptor locations.
2. Five additional residences are located approximately 2,500 feet south of intersection.
3. Additional residences are located north along U.S. Route 87.

Transmission System

The proposed Transmission System would be comprised of a wooden H-frame design with a double circuit 161kV transmission line and a parallel single circuit 161kV transmission line (refer to Figure 2-7 for details) located adjacent to the railroad right-of-way. The three proposed transmission lines would interconnect with the Broadview Substation and follow the permitted railroad right-of-way. Ambient noise measurements along the transmission route were not taken, but are similar to location 2 in Table 3-15 and considered typical for sparsely populated rural areas (ASA, 1998). The Transmission System could generate a small amount of audible noise, typically during an abnormally foul weather event, such as fog or heavy torrential rain, noticeable only if you were underneath in the corridor. The maximum audible noise levels, based upon similar designed transmission lines utilizing single conductors, is projected to be well under the 55 dBA levels at the right-of-way, measured from the center line. The lines are not expected to be audible nor approach the limit of the measured background noise levels. They would not be audible at any of the closest noise sensitive receptors, which were verified to be further than 300 feet from the right-of-way. No noise impact whatever is predicted for this Transmission System.

Mine and Railroad

To help determine the general existing ambient noise levels in the area, before the construction and operation of the Mine and railroad, noise level measurements were conducted in January 2002 during the daytime and nighttime hours at three representative locations near groups of residences (Figure 3-6) but the measurements were not conducted at the specific receptor locations (Table 3-14). When ambient noise levels are low, such as at night, individual noises tend to be more noticeable and, therefore, have a greater potential to adversely affect people by causing annoyance and disturbing sleep.

The noise level measurements were conducted in general accordance with the ASTM Standard E1014-84 (ASTM, 1984). Each measurement was 15 minutes long, and the ground at each measurement location was snow-covered. The equivalent noise level, L_{eq} , and the 90th percentile-exceeded noise level, L_{90} , for each 15-minute period were recorded, and this information was used to estimate the general ambient noise level conditions at the residences. Table 3-15 summarizes the measured ambient noise levels, and the measurement locations are depicted on Figure 3-6.

The measured ambient noise levels are typical for sparsely populated rural areas (ASA, 1998). The measured noise levels were used to estimate the existing ambient noise levels at the five receptor locations before the construction of the mine and railroad (Table 3-15) and used as part of the noise analysis. Since the measured ambient levels are typical for sparsely populated rural areas, the day-night noise level for similar areas is L_{dn} 35 dBA.

Table 3-15 Measured Ambient Noise Levels Near Receptor Locations Before Construction of the Bull Mountains Mine No. 1 and Railroad

Location	Description	Date: 01/22/02 Time	Measured Noise Levels	Notes ⁴
1 ¹	Approximately 7,000 feet southeast of the Generation Plant site; 180 feet north of Fattig Creek Road and PM Coal Road intersection; and 8,700 feet east of U.S. 87.	2:42 to 2:57 p.m.	L_{eq} 34 dBA L_{90} 27 dBA	Vehicles on Fattig Creek and Old Divide Road appeared to be the dominant noise sources during the measurement. Traffic noise on U.S. 87 was very faint. Other noise sources included wind blowing in trees and livestock in distance.
		10:17 to 10:32 p.m.	L_{eq} 33 dBA L_{90} 18 dBA	Field engineer's footsteps on the snow were the dominant noise source. Other audible sources included a commercial jet and a dog barking in the distance. Traffic on U.S. 87 appeared very faint.
2 ²	Approximately 1,500 feet south of plant site; 1,000 feet north of Old Divide Road; and 3,400 feet east of U.S. 87.	3:14 to 3:24 p.m.	L_{eq} 38 dBA L_{90} 33 dBA	Vehicles on U.S. 87 and wind blowing in trees appeared to be the dominant noise sources during the measurement. A commercial jet was audible in the distance.
		10:50 to 11:05 p.m.	L_{eq} 32 dBA L_{90} 19 dBA	Field engineer's footsteps on the snow were the dominant noise source. Other audible sources included a dog barking in the distance, a buzzing streetlight, and two cars passing on U.S. 87.
3 ³	Approximately 5,500 feet south-southeast of plant site; 300 feet east of 90° turn in Cole Road; 800 feet east of U.S. 87.	4:10 to 4:25 p.m.	L_{eq} 41 dBA L_{90} 29 dBA	Vehicles on U.S. 87 appeared to be the dominant noise source during the measurement. Other audible sources included singing birds.
		11:21 to 11:36 p.m.	L_{eq} 32 dBA L_{90} 20 dBA	Field engineer's footsteps on the snow and an occasional vehicle on U.S. 87 were the dominant noise sources. Other audible sources included a commercial jet in the distance and a car pulling into a residence west of the measurement location.

Notes:

1. Measurement location 1 has a direct line of sight to the proposed plant site, but U.S. 87 is not visible.
2. Measurement location 2 has a direct line of sight to the proposed plant site, and U.S. 87 is partially visible.
3. Measurement location 3 has a direct line of sight to the proposed plant site, but U.S. 87 is not visible.
4. Weather during daytime measurements: 25-30°F, 35-40% relative humidity, wind speed 7-10 miles per hour from the west. Weather during nighttime measurements: 10-15°F, 35-40% relative humidity, wind was calm.

When final construction for the Mine, its associated facilities, and its associated railroad begins, these facilities would contribute to the ambient noise at the receptors. Based on data and information provided in the Bull Mountains Mine FEIS (Montana Department of State Lands, 1992), the day-night noise levels at the receptors once the mine is operational were estimated and are summarized in Table 3-16.

Table 3-16 Approximate L_{dn} Levels at Receptor Locations Due to the Operation of the Bull Mountains Mine No. 1 and Railroad

Receptor	Approximate L _{dn} Levels
A	43
B	44
C	38
D	40
E	32

Since the Mine has been approved, and the Project would be completed after the mine and railroad are operational, L_{dn} noise levels due to the mine and the railroad operations were approximated to represent the existing ambient noise levels at the receptors.

The measured ambient noise levels do not currently include railroad or traffic noise associated with the Mine. The levels shown in Table 3-16 represent a reasonable approximation of ambient noise levels after the Mine and railroad are operational.

The existing noise environment does not predict railroad traffic noise and does not extrapolate highway traffic noise. Noise studies cannot be conducted without the proposed activity being present.

There may be different equipment and machinery used at the mine site and the physical environment would change over time with the final placement of the railroad spur line. Sound attenuation levels may be different from these approximated levels due to current construction practices.

Figure 3-6 Noise

3.11 Land Use

3.11.1 Overview

This section presents an overview of the land use resources within the Generation Plant Study Area and the Transmission System Study Area. The resultant analysis establishes a land use baseline used in Chapter 4 to identify and assess the potential environmental impacts that may result from the construction, operation, and maintenance of the proposed Project.

3.11.2 Inventory Methods

The Generation Plant Study Area for land use resources generally encompasses lands within a one-mile radius of the proposed Generation Plant. The Transmission System Study Area for land use resources encompasses lands within a 1.5-mile-wide corridor centered along the proposed 161kV Transmission System.

The following discussion of land use is based on information provided by federal, state, and local government agencies and field reconnaissance of the Project site conducted in October 2002. The discussion also includes information extracted from the following documents: Supplemental EIS Support Document (Bull Mountain Development Company, LLC, 2002a) and Bull Mountains Mine FEIS (Montana Department of State Lands, 1992). Milepost references in this section can be found on the Roundup Generation Plant land use resource map, Figure 3-7.

3.11.3 Inventory Results

Generation Plant

The proposed Generation Plant would be located in the Bull Mountains region of central Montana. This region has considerable diversity in topography and economic activity. Farming, livestock ranching, timber production, mining, and some urban and residential development contribute to the economic base. The topography includes ridges capped by sandstone mesas, rolling hills, and gently sloping valleys. Ponderosa pine and Rocky Mountain juniper are common at higher elevations, with sagebrush and prairie grassland communities on benches, slopes, and drainages. The proposed Generation Plant would be situated in gently rolling upland terrain.

Existing Land Use Plans

The Generation Plant Study Area is within Musselshell County. While under the jurisdiction of the Musselshell County Comprehensive Plan, which was adopted in 1973, the area is not zoned. The Comprehensive Plan is currently being updated, but the revised plan is not expected to be available before 2003 (Danielson, 2002). The 1973 Comprehensive Plan does not include land use planning or management recommendations for unincorporated areas such as the Generation Plant Study Area. The revised Comprehensive Plan also is not expected to include land use planning or management recommendations for unincorporated areas.

Current Land Ownership

The proposed site for the Generation Plant and associated one-mile Generation Plant Study Area radius are located within Musselshell County. More specifically, the proposed Generation Plant would be located in Section 15, Township 6 North, Range 26 East. Land ownership within the Generation Plant Study Area consists primarily of private land with lesser amounts of Montana School Trust Land.

Current Land Use Characteristics and Trends

As of 1997 (the latest year for which statistics are available), approximately 95 percent of the land in Musselshell County was used for farming and/or ranching (Danielson, 2002).

Approximately 40 percent of the land was classified as forest, but much of this land was grazed. Therefore, it is included in the ranch acreage. Approximately 5 percent of the land was in subdivisions, but much of this land had not yet been developed. Approximately 0.1 percent of the land was classified as urban, primarily in the City of Roundup and the Town of Melstone. There were no active mines in the county and no large-scale industry outside of the urban areas (Danielson, 2002).

Most private land holdings in Musselshell County originally were large parcels created when ranchers and miners settled the area. In recent years, rural subdivisions and other land divisions have split some of these large parcels into multiple smaller lots. As of 1999, there were 3,657 property parcels in the unincorporated parts of Musselshell County, of which 1,185 were improved with a house or house trailer (Danielson, 2002).

In the eight sections contiguous to Section 15, Township 6 North, Range 26 East where the proposed Generation Plant would be located (Sections 9, 10, 11, 14, 16, 21, 22, and 23, Township 6 North, Range 26 East), there are seven parcels of 640 acres or 320 acres (Musselshell County GIS Department 1999). However, four of the sections (Sections 9, 10, 22, and 23) have been subdivided, partially or entirely, into smaller lots. In these sections, there are approximately 105 smaller parcels, mostly 10 or 20 acres in size. These eight sections are generally referred to in this section as the vicinity of the proposed Generation Plant.

Land use near the proposed Generation Plant mirrors the trends in Musselshell County. Livestock grazing occurs within the Generation Plant Study Area but is not authorized on the site itself.

Montana School Trust Land is also located within the Generation Plant Study Area. This land is situated west of the proposed Generation Plant site in Section 16, Township 6 North, Range 26 East. School Trust Land Managers in the Montana Department of Natural Resources and Conservation (DNRC) manage each parcel to raise money for the state's Public School Trust Fund. The Southern Land Office of the DNRC has indicated that Section 16 is currently leased for grazing (cattle) and has an estimated carrying capacity of 150 animal unit months. Development of the Generation Plant site is expected to be compatible with this type of use (Brandenburg, 2002).

Figure 3-7 Land Use

A small area in the center of the proposed Generation Plant site is classified as commercial forest (Musselshell County GIS Department, undated), apparently because it produced commercial-grade timber at some time in the past. However, this area does not currently support large trees.

Some non-irrigated cropland can be found in the Generation Plant Study Area. Crops produced in Musselshell County include wheat, barley, oats, and hay (Charlton, 2002). No irrigated cropland, registered apiaries, or Conservation Reserve Program (CRP) land was identified within the Generation Plant Study Area or vicinity of the proposed Generation Plant.

Other than agriculture and the transportation corridor provided by U.S. Route 87, the only significant land use within the Generation Plant Study Area is small residential and religious developments. Shining Mountain Christian Ranch is located in Section 22, just south of the proposed Generation Plant site. This small development, which reportedly is used for religious retreats, includes one residential building and one house trailer.

Bull Mountains Community Church is located in Section 23, south-southeast of the proposed Generation Plant site. This small development includes a church building, a lodge, and a house trailer.

Eight residences were identified within the Generation Plant Study Area. Most of these residences are located south-southeast of the proposed Generation Plant site, primarily in the subdivided areas. Overall, Section 9 contains 12 housing units, Section 10 contains seven housing units, Section 14 contains one housing unit, Section 21 contains one housing unit, Section 22 contains eight housing units, and Section 23 contains 24 housing units. Sections 11 and 16 contain no occupied housing units (based on Musselshell County tax records).

The nearest commercial establishment is the Brandin' Iron Saloon, which is located along U.S. Route 87, approximately two miles north-northwest of the proposed Generation Plant site. A proposed commercial establishment (Whispering Pines Kettle Express) was also identified along U.S. Route 87, approximately 1.75 miles northwest of the proposed Generation Plant. This establishment would include a proposed convenience store and a log furniture store. Other plans for the site include a recreational vehicle park and rough golf course.

The nearest schools, hospitals, and industrial developments are found in the City of Roundup. The PM Mine, an underground coal mining operation, was located partially in Section 14, east of the proposed Generation Plant site.

The PM Mine ceased operation in the 1990s, but the Bull Mountains Mine No. 1 plans to resume mining in the same area.

No private land conservation easements were identified within the Generation Plant Study Area.

Recreation

Recreational land use near the proposed Generation Plant site includes dispersed outdoor activities such as hunting and horseback riding. In 2001, 3,323 deer hunters generated 14,235 hunter days of recreation and 515 elk hunters generated 3,443 hunter days of recreation in Hunting District 590. The Generation Plant Study Area is located within this deer and elk hunting district. In 1995, 528 turkey hunters in Musselshell County generated 1,559 hunter days. Big game hunting season opens approximately in the middle of October and runs through

Thanksgiving weekend. There are both spring and fall seasons for turkey hunting (Newell, 2002).

Recreational use of Montana School Trust Land (Section 16, Township 6 North, Range 26 East) may include hunting and hiking. Since most land near the proposed Generation Plant is privately owned, access for recreational pursuits is dependent upon landowner permission.

The nearest public recreation facilities (including a golf course, tennis courts, and swimming pool) are in the City of Roundup, more than 13 miles from the proposed Generation Plant.

Transmission System

The following sections describe the general land use along the Transmission System route.

The Transmission System and associated 1.5-mile-wide study corridor fall within the counties of Musselshell and Yellowstone in central Montana. The Transmission System generally would parallel a proposed railroad spur from the Bull Mountains Mine No. 1 to the Burlington Northern and Santa Fe Railway main line south of the City of Broadview. The route traverses land ranging from wooded hills and grassy valleys with some small, steep-sided canyons on the eastern end, to flat, open fields and lowlands on the western end.

Existing Land Use Plans

The Transmission System Study Area in Musselshell County and Yellowstone County is not zoned and under jurisdiction of the Musselshell County Comprehensive Plan and the Yellowstone County Comprehensive Plan, respectively.

The Musselshell County Comprehensive Plan was adopted in 1973 and is currently being updated. The revised plan is not expected to be available before 2003 (Danielson, 2002). The 1973 Comprehensive Plan does not include land use planning or management recommendations for unincorporated areas, such as the Transmission System Study Area. The revised Comprehensive Plan also is not expected to include land use planning or management recommendations for unincorporated areas (Danielson, 2002). Goals and objectives in the 1973 Comprehensive Plan do not specifically address the siting of major transmission lines.

The Yellowstone County Comprehensive Plan was adopted in 1990 and is currently being updated. Goals, policies, and implementation strategies in the 1990 Comprehensive Plan do not specifically address the siting of major transmission lines.

Current Land Ownership

Land ownership within the Transmission System Study Area consists primarily of private land with lesser amounts of Montana School Trust Land. The Transmission System would cross both private land and Montana School Trust Land.

Current Land Use Characteristics and Trends

According to Musselshell County Facts At-A-Glance – Land Mass Data in Acres (1999 data), approximately 0.1 percent of the land was classified as urban. According to the Yellowstone County Comprehensive Plan, approximately three percent of the land in Yellowstone County is urban or urban built-up area. The remaining land in both counties is primarily agricultural,

including rangeland, forest areas (forest cover and commercial forest), cropland, and pasture. There also are limited areas of rural/suburban tracts.

A variety of land uses exist in the Transmission System Study Area, including scattered residences, ranches, rangeland, non-irrigated cropland, roads and highways, railroads, utility rights-of-way for electrical power lines and telephone, communication sites, oil/gas pipelines, and recreation. In addition, an air facility was identified from a Yellowstone County Map prepared by the Montana Department of Transportation in cooperation with the U.S. Department of Transportation Federal Administration with revisions September 18, 2001. The air facility on the map is designated as a Landing Area or Strip and is located approximately one mile north of the Transmission System and $\frac{1}{4}$ of a mile north of the Transmission System Study Area (Section 11, Township 4 North, Range 24 East). This mapped air facility was not verified in the field. Twenty-five residences were identified in the Transmission System Study Area. The general locations of these residences by milepost are as follows:

- One residence from milepost 2 to milepost 3
- Seven residences from milepost 5 to milepost 10
- Four residences from milepost 13 to milepost 14
- Seven residences from milepost 17 to milepost 19
- Five residences from milepost 22 to milepost 25
- One residence from milepost 27 to milepost 28

No residences would be crossed by the Transmission System.

The Transmission System Study Area would traverse a variety of agricultural uses. The eastern end of the study area primarily consists of grazing land with ponderosa pine cover. The remaining portion is principally of fields of small grains, hay wheatgrass lowlands, alkali/salt grasslands, and CRP lands. Crops produced in Musselshell County includes wheat, barley, oats, and hay (Charlton, 2002). Crops in the Transmission System Study Area of Yellowstone County consist primarily of wheat with lesser amounts of barley, oats, and hay (Gaglia, 2002). The general location of non-irrigated cropland and CRP land by milepost are as follows:

Non-irrigated Cropland

- from milepost 0 to milepost 1
- from milepost 4 to milepost 5
- from milepost 6 to milepost 7
- from milepost 8 to milepost 9
- from milepost 13 to milepost 14
- from milepost 17 to milepost 18
- from milepost 21 to milepost 22
- from milepost 24 to milepost 26

CRP Land

- from milepost 5 to milepost 6
- from milepost 7 to milepost 8
- from milepost 9 to milepost 12
- from milepost 16 to milepost 17
- from milepost 18 to milepost 21
- from milepost 22 to milepost 24

Parcels of Montana School Trust Land within the Transmission System Study Area that would be crossed by the Transmission System are located in Section 32, Township 6 North, Range 26 East; Section 16, Township 5 North, Range 25 East; and Section 14, Township 4 North, Range 24 East. Lease information provided by the Southern Land Office of the DNRC for these sections indicated the following:

- A lease in Section 32 of 315.83 acres (280 grazing acres with an estimated carrying capacity of 56 animal unit months and 35.83 acres listed as unsuitable).
- Three leases in Section 16. Lease #3453 totaling 315.57 acres (228 acres in CRP and 87.57 grazing acres with an estimated carrying capacity of 32 animal unit months). Lease #5762 totaling 320 acres (205.9 acres in CRP and 114.1 grazing acres with an estimated carrying capacity of 31 animal unit months). Lease #9683 totaling 4.43 acres for a homesite.
- A lease in Section 14 of 160 acres (147.7 acres in CRP and 12.3 acres unused).

Recreation

Recreational land use within and adjacent to the Transmission System Study Area includes dispersed outdoor activities such as hunting and horseback riding. Recreational use of Montana School Trust Land in the Transmission System Study Area may include hunting and hiking. Since most land along the proposed Transmission System Study Area is privately owned, access for recreational pursuits is dependent upon landowner permission. Public recreation facilities (including a golf course, tennis courts, and swimming pool) can be found in the City of Roundup, more than 13 miles from the proposed Generation Plant site and in the BLM's Acton Recreation Area, located approximately 10 miles southeast of the City of Broadview. Recreational activities within the Acton Recreation Area include hunting, horseback riding, and all-terrain vehicle use. The Transmission System would be located approximately 3.5 miles north of the recreation area.

3.12 Socioeconomics

3.12.1 Overview

The following sections include socioeconomic data for the Project including population and housing, employment, taxes, education services, transportation, utilities, health and safety, and social well being.

3.12.2 Socioeconomic Methods

The study areas for the Generation Plant and Transmission System are considered together in this analysis. Some socioeconomic patterns may differ across these areas but are not significant enough to report as part of the inventory results. Therefore, throughout the following sections, the Generation Plant and Transmission System are referred to jointly as the “Study Area.”

The socioeconomic Study Area for the Project includes Musselshell County and its sub-jurisdictions. Selected data for adjacent Yellowstone County, the City of Billings, and other areas are also presented because some of the Project impacts would occur outside of Musselshell County. In each case, the data are presented for the smallest spatial area available. For example, annual employment is published only on a countywide basis, while population and housing information are available for sub-county areas.

3.12.3 Socioeconomic Results

Population and Housing

The population of Musselshell County rose from 4,106 in 1990 to 4,497 in 2000, an increase of 391 persons, or 10 percent, as reported in Table 3-17. Most of this increase was in the Klein County Census Division (CCD), where population increased 393 persons or slightly more than 39 percent. There are a number of new homes just inside Musselshell County’s southern border. Many of these persons are retired or commute to Billings, rather than to a job in Roundup or elsewhere in the county. Population in the rest of the county was approximately stable. The Roundup CCD increased by roughly 100 persons and the Melstone CCD decreased by approximately 100 persons. Technically, because of the growth in the Klein CCD, Musselshell County experienced small net in-migration between 1990 and 2000. The Project would be located in the Klein CCD.

Table 3-17 1990 and 2000 Population - Musselshell and Yellowstone Counties and Selected Areas

Area	1990	2000	Change	Percent Change
State of Montana	799,000	902,000	103,000	13
Musselshell County	4,106	4,497	391	10

Klein CCD	1,002	1,395	393	39
Melstone CCD	584	476	-108	-18
Melstone Town	166	136	-30	-18
Roundup CCD	2,520	2,626	106	4
Roundup City	1,808	1,931	123	7
Yellowstone County	113,419	129,353	15,934	14

Sources: U.S. Bureau of the Census, 1990 and 2000 Census of Population

The median age in Musselshell County was 43.2 years in 2000. The median age for Montana was 37.5 years and the figure for Yellowstone County was 36.9 years. Within Musselshell County, the highest median age was in the Klein CCD (45.9 years), providing some evidence that retirees occupied the new homes. The median age was 41.8 years in the Roundup CCD and 41.5 years in the Melstone CCD (U.S. Bureau of the Census, 2000, <http://www.census.gov>). A summary of the Study Area's population by age is presented below in Table 3-18.

Table 3-18 Population by Age: Bull Mountains Study Area

Place/Age	1980	Percent of Total	1990	Percent of Total	2000	Percent of Total
Montana Total	787,690	100.0	799,065	100.0	902,195	100.0
0 to 4 Years	64,455	8.2	59,257	7.4	54,869	6.1
5 to 17 Years	167,440	21.3	162,847	20.4	175,193	19.4
18 to 64 Years	470,236	59.7	470,464	58.9	551,184	61.1
65+ Years	84,559	10.7	106,497	13.3	120,949	13.4
Musselshell Co. Total	4,428	100.0	4,106	100.0	4,497	100.0
0 to 4 Years	376	8.5	199	4.8	222	4.9
5 to 17 Years	937	21.2	844	20.6	829	18.4
18 to 64 Years	2,419	54.6	2,242	54.6	2,659	59.1
65+ Years	696	15.7	821	20.0	787	17.5
Roundup City Total	2,116	100.0	1,808	100.0	1,931	100.0
0 to 4 Years	186	8.8	100	5.5	119	6.2
5 to 17 Years	343	16.2	357	19.7	364	18.9
18 to 64 Years	1,129	53.4	884	48.9	1,026	53.1
65+ Years	458	21.6	467	25.8	422	21.9
Yellowstone Co. Total	108,035	100.0	113,419	100.0	129,352	100.0
0 to 4 Years	9,013	8.3	8,418	7.4	8,539	6.6

5 to 17 Years	22,665	21.0	22,455	19.8	24,426	18.9
18 to 64 Years	66,516	61.6	68,547	60.4	79,144	61.2
65+ Years	9,841	9.1	13,999	12.3	17,243	13.3
Billings City Total	66,842	100.0	81,151	100.0	89,847	100.0
0 to 4 Years	4,907	7.3	6,036	7.4	5,882	6.5
5 to 17 Years	12,606	18.9	14,785	18.2	15,707	17.5
18 to 64 Years	42,603	63.7	48,977	60.4	54,919	61.1
65+ Years	6,726	10.1	11,353	14.0	13,339	14.8

Source: U.S. Bureau of the Census, 1980, 1990 and 2000 Census of Population

Baseline projections of population and economic characteristics for Musselshell and Yellowstone Counties are presented below in Table 3-19. During the 20-year projection period, the population of Musselshell County, without either the Project or the Bull Mountains Coal Mine project, would be expected to grow at an annual rate of 0.8 percent to 5,290 persons in 2020. This projected growth is nearly identical to the 0.8 percent annual population growth in Musselshell County between 1990 and 2000. By the year 2010, Musselshell County employment would be projected to rise about 13.1 percent to 2,330. The population of Yellowstone County would be projected to rise from 129,352 in 2000 to 162,410 in 2020, or an average of 1.1 percent per year. This projected growth rate is slightly slower than the 1.3 percent annual rate between 1990 and 2000. Yellowstone County employment would be projected to increase 33.7 percent between 2000 and 2020.

Table 3-19 Baseline Economic Projections for Montana, Musselshell County, and Yellowstone County, 2000 to 2020

Place/Type	2000	2005	2010	2015	2020
Montana					
Population	902,200	952,150	1,000,870	1,053,490	1,108,910
Employment	565,300	618,400	669,940	712,520	750,030
Per Capita Income (1996\$)	\$22,307	\$25,089	\$27,658	\$29,783	\$31,790
Musselshell County					
Population	4,497	4,680	4,860	5,070	5,290
Employment	2,060	2,130	2,210	2,280	2,330
Per Capita Income (1996\$)	\$16,701	\$19,128	\$21,521	\$23,625	\$25,660
Yellowstone County					
Population	129,352	137,990	145,880	154,040	162,410
Employment	91,030	99,840	108,340	115,440	121,790
Per Capita Income (1996\$)	\$25,542	\$28,392	\$30,971	\$33,010	\$35,049

Source: National Planning Association 2002.

The number of housing units in Musselshell County increased from 2,183 in 1990 to 2,317 in 2000, a rise of 9.2 percent. All of this increase occurred in the Klein CCD, which encompasses the southwestern portion of Musselshell County, just to the west of the proposed Generation Plant site. The number of housing units in the Klein CCD rose from 549 in 1990 to 689 in 2000, and probably represents new suburban Billings housing located just north of the Musselshell County line. There were 41 seasonal housing units in the Klein CCD, many of which may be recreational housing. The number of housing units in the Melstone CCD, which is the northeastern portion of Musselshell County, declined from 287 in 1990 to 284 in 2000. In the Roundup CCD, the northwestern portion of the county, the number of housing units decreased slightly from 1,347 in 1990 to 1,344 in 2000 (U.S. Bureau of the Census, 2000 Census of Population, www.census.gov).

The city of Roundup had 1,006 housing units in 1990 and 978 in 2000. The corresponding figures for Melstone were 88 in 1990 and 87 in 2000 (U.S. Bureau of the Census, 2000 Census of Population, www.census.gov).

The 2000 Musselshell County homeowner vacancy rate was 6.8 percent and the rental vacancy rate was 8.4 percent. Both of these vacancy rates were much lower in the Klein CCD than in the remainder of the county. The Klein CCD homeowner vacancy rate was 2.7 percent while the vacancy rate for rentals was 2.6 percent. The homeowner vacancy rate in the Melstone CCD was 11.9 percent, and the rental vacancy rate was 10.5 percent. In the Roundup CCD, the homeowner vacancy rate was 8.2 percent and the figure for rentals was 8.4 percent (U.S. Bureau of the Census, 2000 Census of Population, www.census.gov).

Approximately 23.1 percent of the occupied housing units in Musselshell County were rentals in 2000. In the Klein CCD, about 12.8 percent were rentals. Approximately 18.0 percent of the occupied housing units were rentals in the Melstone CCD, while the corresponding figure for the Roundup CCD was 29.3 percent (U.S. Bureau of the Census, 2000 Census of Population, www.census.gov).

There were 145 vacant housing units in Musselshell County in 2000 that were ready for immediate occupancy. About 40 of these units were available for rent and 105 were for sale. Only 16 of these vacant units (2 for rent and 14 for sale) were in the Klein CCD. There were 104 vacant units (34 for rent and 70 for sale) in the Roundup CCD, and 26 vacant units (four-rentals and 21-for sale) in the Melstone CCD (U.S. Bureau of the Census, 2000 Census of Population, www.census.gov).

The number of housing units in Yellowstone County increased from 48,471 in 1990 to 54,563 in 2000. Approximately 30.8 percent of the occupied housing units in 2000 were rentals. The 2000 countywide homeowner vacancy rate was 1.2 percent and the rental vacancy rate was 5.4 percent (U.S. Bureau of the Census, 2000 Census of Population, www.census.gov).

Temporary housing may be provided by hotel/motel rooms and recreational vehicle (RV) spaces. Yellowstone County has 51 hotels/motels with 3,609 licensed units and 13 campgrounds with 337 total licensed RV spots. Musselshell County has three hotels/motels with 30 licensed units and two campgrounds with 12 total licensed units (Bull Mountain Development Company, LLC., 2002a).

Employment

As shown below in Table 3-20, 1999 employment in Musselshell County totaled 1,985, up about 12.8 percent from 1,760 in 1990. Peak employment of 2,064 was recorded in 1997. Agriculture (and related services), mining, and manufacturing are the major basic industries in Musselshell County, and they account for most of the employment trends in the 1990s. Employment in agriculture and related services was 377 in 1999 and remained relatively stable throughout the decade.

As reported in Table 3-20, the mining industry in Musselshell County consists of both coal mining and oil and gas exploration. Mining employment was 148 in 1990. Oil and gas exploration accounted for most of the rise in mining employment to 167 in 1994 and the subsequent decline to 86 in 1995. The rise in mining employment to 101 in 1996 and 107 in 1997 was associated with the short operation of the Mine. By 1998, only oil and gas employment remained, and it declined further in 1999.

Table 3-20 Employment by Broad Industry Musselshell County Selected Years 1970-1999

Year	1970	1980	1990	1991	1992	1993	1994	1995	1996	1997	1998	1999
Total employment	1605	1958	1766	1733	1763	1787	1953	1990	2026	2064	2040	1985
Farm employment	345	321	339	336	335	332	325	323	316	295	318	317
Nonfarm employment	1260	1637	1427	1397	1428	1455	1628	1667	1710	1769	1722	1668
Ag. services, forestry, & other	36	30	41	44	49	43	49	48	56	64	60	60
Mining	197	281	148	113	108	133	167	86	101	107	72	54
Construction	49	75	66	70	89	82	94	121	124	145	144	147
Manufacturing	51	69	41	36	27	32	63	114	101	104	109	103
Transportation and public utilities	48	93	84	73	67	62	69	70	76	79	92	87
Wholesale trade	50	86	67	47	43	45	39	38	34	34	29	33
Retail trade	263	332	278	299	305	312	343	365	390	369	339	334
Finance, insurance, and real estate	92	79	75	69	77	74	73	94	90	104	112	113
Services	262	330	374	373	387	394	455	447	463	481	488	489
Government	212	262	253	273	276	278	276	284	275	282	277	268
Federal, civilian	13	19	20	20	22	20	18	17	17	18	17	16
Military	28	26	32	31	30	29	27	27	27	26	26	26
State and local	171	217	201	222	224	229	231	240	231	238	234	226
State	15	24	14	15	16	15	14	16	17	18	17	16

Year	1970	1980	1990	1991	1992	1993	1994	1995	1996	1997	1998	1999
Local	171	193	187	207	208	214	217	224	214	220	217	210

Source: U.S. Bureau of Economic Analysis, Regional Economic Information System (REIS), 2001

The largest component of manufacturing in Musselshell County is lumber and wood products, as reported in Tables 3-21 and 3-22. The growth in manufacturing employment was mostly due to the opening of a stone-clay-glass firm, non-electrical machinery manufacturer, and a miscellaneous manufacturing firm.

Yellowstone County serves as the trade and service center for southeastern Montana and a disproportionate share of the jobs are in retail trade, wholesale trade, and the services (Table 3-21). Between 1990 and 1999, total employment increased 26.0 percent.

Unemployment in Musselshell County during the 1990s has ranged from a low of 6.1 percent in 1993 to a high of 8.6 percent in 1995. Generally, the low unemployment rates occurred during the years of peak mining employment (1993-94 and 1996-97) while the high rates were during the years when mining employment decreased (1995 and 1999). Overall, unemployment rates in Musselshell County averaged about 1.5 to 2.0 percent higher than statewide, as shown below in Table 3-22. Unemployment rates in Yellowstone County have been less than the statewide average throughout the 1990s.

Per capita personal income in Musselshell County is among the lowest in the state and its relative position deteriorated in the 1990s. As reported in Table 3-23, the 1990 Musselshell County per capita personal income was \$12,377, about 79.7 percent of the statewide average of \$15,524. By 1999, this figure had risen to \$14,654, but this was only 66.6 percent of the Montana average of \$21,997. Stated differently, per capita income in Musselshell County ranked 48 out of 56 counties in 1990, and had dropped to 55 out of 56 counties by 1999. Per capita income in Yellowstone County was consistently above the statewide average. It was 113.0 percent of the state figure in 1990, and rose to 114.8 percent in 1999. Yellowstone County ranked fourth in 1990 and rose to second by 1999.

Taxes

There are several local government entities in Montana with taxing and spending authority. County and city governments have general responsibilities for law enforcement, judiciary, road, and other functions within their boundaries. School districts are responsible for education. There may also be special districts established for specific purposes, such as weed or mosquito control, that can levy taxes within their boundaries.

Property taxes account for most of the local revenue received by local governments and taxing authorities. As shown in Table 3-24, governmental entities in Musselshell County (county, city, and schools) had total revenue about \$9.4 million in 1997. Subtracting federal government revenue of \$364,000 and the \$5.1 million received from the state (mostly state equalization payments for education) yields a figure of \$3.9 million, which derived from local sources. About \$2.5 million of the locally derived revenue came from taxes, and almost all of that was from property taxes. Property taxes accounted for about 63.9 percent ($2,472/3,867 = .639$) of locally derived revenue. Musselshell County is relatively more dependant on property taxes; the same

calculations yield figures of 46.7 percent for Yellowstone County and 53.7 percent for Montana for the percentage of local revenue derived from property taxes.

Per capita revenues and expenditures for both Yellowstone and Musselshell counties are below their respective statewide averages. Musselshell County had revenues per capita of \$2,010, about 97 percent of the statewide average of \$2,070. Per capita expenditures in Musselshell County were \$1,887, about 87 percent of the statewide average of \$2,126. The corresponding Yellowstone County figures for both per capita revenues and expenditures were 95 percent of the respective statewide averages.

Property taxes in Montana are computed by multiplying the jurisdiction's tax rate (expressed in mills) by the taxable valuation within its boundaries. Taxable valuation is computed by applying one of nine rates (from 3 to 100 percent) to the market value of a taxable item. For example, residential property is taxed at 3.974 percent of its market value, with some important exceptions. Centrally assessed electric power company assets are taxed at 12 percent of its market value. There are also provisions for reducing the rate for certain types of property if they qualify as new industrial property.

Taxable valuations and mill rates in Musselshell and Yellowstone counties are shown in Table 3-25. In 1999-2000, Musselshell County had total mills of 115.75 and a taxable valuation \$7.3 million. Persons living in Roundup paid an additional 95.36 mills, and those in Melstone paid an additional 134.02 mills. County governments compute and collect all the property taxes within their jurisdiction. Musselshell County billed \$3.1 million in 1999-2000 for the taxes due to county, city, school districts, and special districts within its boundaries.

The Roundup School general fund budget was \$4,612 for each high school pupil and \$3,762 for each elementary school pupil (Bull Mountain Development Company, LLC., 2002a). The figures for Melstone were \$7,951 for each high schools pupil and \$4,882 for each elementary pupil. The Billings figures were \$4,454 for each high school pupil and \$4,033 for each elementary pupil. In Laurel, they were \$4,573 for each high school pupil and \$4,228 for each elementary pupil. No corresponding statewide averages were published.

Table 3-21 Employment in Montana, Musselshell County, and Yellowstone County- 1990 and 1999

	Montana				Musselshell County				Yellowstone County			
	1990 Number	Percent of Total	1999 Number	Percent of Total	1990 Number	Percent of Total	1999 Number	Percent of Total	1990 Number	Percent of Total	1999 Number	Percent of Total
Total employment	436,574	100	552,276	100	1,766	100	1,985	100	70,506	100	88,846	100
Farm employment	30,576	7.0	32,122	5.8	339	19.2	317	16.0	1,288	1.8	1,431	1.6
Nonfarm employment	405,998	93.0	520,154	94.2	1,427	80.8	1,668	84.0	69,218	98.2	87,415	98.4
Ag. services, forestry, & other	6,154	1.4	8,554	1.5	41	2.3	40	2.0	568	0.8	848	1.0
Mining	7,824	1.8	6,498	1.2	148	8.4	54	2.7	879	1.2	653	0.7
Construction	19,070	4.4	34,527	6.3	66	3.7	147	7.4	2,842	4.0	5,526	6.2
Manufacturing	26,342	6.0	29,287	5.3	41	2.3	103	5.2	3,545	5.0	3,730	4.2
Transportation and public utilities	23,858	5.5	27,327	4.9	84	4.8	87	4.4	4,576	6.5	5,430	6.1
Wholesale trade	17,449	4.0	20,784	3.8	67	3.8	33	1.7	5,818	8.3	6,750	7.6
Retail trade	78,715	18.0	104,951	19.0	278	15.7	334	16.8	14,045	19.9	18,232	20.5
Finance, insurance, and real estate	27,693	6.3	36,927	6.7	75	4.2	113	5.7	5,935	8.4	6,231	7.0
Services	118,623	27.2	167,868	30.4	374	21.2	489	24.6	22,246	31.6	30,763	34.6
Government	80,270	18.4	83,431	15.1	253	14.3	268	13.5	8,764	12.4	9,252	10.4
Federal, civilian	13,771	3.2	12,522	2.3	20	1.1	16	0.8	1,811	2.6	1,724	1.9
Military	10,516	2.4	8,563	1.6	32	1.8	26	1.3	897	1.3	735	0.8
State and local	55,983	12.8	62,346	11.3	201	11.4	226	11.4	6,056	8.6	6,793	7.6
State	21,561	4.9	23,571	4.3	14	0.8	16	0.8	1,588	2.3	1,713	1.9

U.S. Bureau of Economic Analysis, Regional Economic Information System (REIS), 2001

Table 3-22 Labor Force Statistics Montana, Musselshell County, and Yellowstone County (Selected Years, 1970-2000)

Place/Category	1970	1980	1990	1991	1992	1993	1994	1995	1996	1997	1998	1999	2000
Montana													
Civilian Labor Force	273,000	371,000	401,000	407,000	422,000	426,000	439,502	437,098	445,910	454,614	466,450	474,006	479,132
Employed Persons	261,000	348,000	377,000	378,000	393,000	400,000	417,225	411,306	422,434	430,261	440,248	449,361	455,608
Unemployed Persons	12,000	23,000	24,000	29,000	29,000	26,000	22,277	25,792	23,476	24,353	26,202	24,645	23,524
Unemployment Rate	4.4	6.2	6.0	7.1	6.9	6.1	5.1	5.9	5.3	5.4	5.6	5.2	4.9
Musselshell County													
Civilian Labor Force	1,440	1,841	1,785	1,781	1,816	1,805	1,893	1,933	1,932	1,938	1,972	1,853	1,868
Employed Persons	1,333	1,798	1,658	1,641	1,680	1,694	1,772	1,766	1,776	1,786	1,826	1,700	1,729
Unemployed Persons	107	43	127	140	136	111	121	167	156	152	146	153	139
Unemployment Rate	7.4	2.3	7.1	7.9	7.5	6.1	6.4	8.6	8.1	7.8	7.4	8.3	7.4
Yellowstone County													
Civilian Labor Force	35,170	55,542	61,648	62,518	65,170	65,732	68,013	66,830	67,239	68,540	70,133	72,121	72,921
Employed Persons	32,966	52,861	58,563	59,101	61,517	62,508	65,300	63,611	64,247	65,433	67,049	69,224	70,158
Unemployed Persons	2,204	2,681	3,085	3,417	3,653	3,224	2,713	3,219	2,992	3,107	3,084	2,897	2,763
Unemployment Rate	6.3	4.8	5.0	5.5	5.6	4.9	4.0	4.8	4.4	4.5	4.4	4.0	3.8

U.S. Bureau of Economic Analysis, Regional Economic Information System (REIS), 2001

Table 3-23 Per Capita Personal Income, Montana, Musselshell and Yellowstone Counties, 1990 and 1999

Area	1990		1999	
	Per Capita Income	Percent of Montana	Per Capita Income	Percent of Montana
Montana	\$15,524	100.0	\$21,997	100.0
Musselshell County	12,377	79.7	14,654	66.6
Yellowstone County	17,536	113.0	25,253	114.8

Source: U.S. Bureau of Economic Analysis, Regional Economic Information System (REIS), 2001.

Table 3-24 County and Local Government Revenue and Expenses 1997

	Musselshell County	Yellowstone County	Montana
(thousands of dollars)			
General Revenue	9,397	246,842	1,821,669
<i>per capita (dollars)</i>	<i>2,010</i>	<i>1,960</i>	<i>2,070</i>
Federal Intergovernmental Revenue	364	3,809	91,641
State Intergovernmental Revenue	5,166	78,043	632,393
Total Taxes	2,543	83,491	622,237
Property Taxes	2,472	77,090	590,177
General Current Charges	876	54,265	311,490
Interest Revenue	160	9,249	84,283
Other Revenue	288	17,985	79,625
Total Expenditures	8,810	250,237	1,869,516
<i>per capita (dollars)</i>	<i>1,884</i>	<i>1,960</i>	<i>2,126</i>

Source: (U.S. Bureau of the Census, 1997 Census of Governments, www.census.gov)

Note: Includes county government, municipal governments, and school districts.

Table 3-25 Taxable Valuation, Tax Mill and Property Taxes Billed Yellowstone and Musselshell Counties and Selected Cities 1999-2000

City/County	Total Mills	Taxable Valuation	Property Taxes Billed*
Musselshell County	115.75	\$7,251,247	\$3,162,915
Roundup City	95.36	1,602,953	
Melstone town	134.02	99,496	
Yellowstone County	80.74	\$223,126,552	\$117,082,228
Billings City	94	122,789,770	
Laurel City	95.51	6,694,717	

* includes county, city, and school district levies

Source: Bull Mountain Development Company, LLC., 2002a.

Education Services

The Roundup School District and the Melstone School District operate the only public schools within Musselshell County. Both districts maintain elementary, 7-8 grade, and a high school. The Musselshell School District was dissolved in the late 1990s, and the students were dispersed to the Roundup and Melstone school districts.

Yellowstone County contains the Billings School District, plus 15 other elementary school districts, which are shown in Table 3-26. The 16 elementary districts feed students into eight high schools.

As presented in Table 3-26, school enrollment in Musselshell County decreased from 832 students in the 1990-91 school year to 758 students in the 2000-01 school year, a decline of 8.9 percent. The Roundup School District experienced a decline of 9.1 percent during the 1990s, while the corresponding figure for the Melstone School District was a decrease of 6.9 percent.

Table 3-26 Enrollment by District and School Musselshell and Yellowstone Counties 1990-91 and 2000-01

District and School	1990-91	2000-01	Percent Change
Musselshell County	832	758	-8.9
Roundup	731	664	-9.2
Musselshell School	18		-100.0
Central School	394	316	-19.8
Roundup 7-8	117	109	-6.8
Roundup HS	202	239	18.3
Melstone	101	94	-6.9

District and School	1990-91	2000-01	Percent Change
Melstone School	39	43	10.3
Melstone 7-8	18	15	-16.7
Melstone HS	44	36	-18.2
Yellowstone County	20,968	21,434	2.2
TOTAL K-8	15,371	14,706	-4.3
Billings K-8	10,815	10,160	-6.1
Lockwood K-8	1,157	801	-30.8
Blue Creek K-8	95	173	82.1
Canyon Creek K-8	195	265	35.9
Laurel K-8	1,342	1,185	-11.7
Elder Grove K-8	192	316	64.6
Custer K-8	72	73	1.4
Morin K-8	27	31	14.8
Broadview K-8	75	116	54.7
Elysian K-8	89	120	34.8
Huntley Project K-8	494	522	5.7
Shepard K-8	501	584	16.6
Pioneer K-8	67	61	-9.0
Independent K-8	165	238	44.2
Yellowstone Academy	85	61	-28.2
TOTAL H.S.	5,597	6,728	20.2
Billings Sr. H.S.	1,688	1,956	15.9
Billings West H.S.	1,633	1,997	22.3
Skyview H.S.	1,254	1,571	25.3
Laurel H.S.	564	586	3.9
Custer H.S.	30	31	3.3
Broadview H.S.	40	52	30.0
Huntley Project H.S.	180	259	43.9
Shepherd H.S.	208	276	32.7

Source: Montana Office of Public Instruction, 2002.

School enrollment in Yellowstone County rose from 20,968 students in the 1990-91 school year to 21,434 students in the 2000-01 school year, a rise of 2.2 percent. A quick glance at the figures

in Table 3-26 reveals a mixed picture in terms of the trends in the various schools and districts. For the most part, they reflect net in-migration of population and the changing central, suburban, and rural area residence patterns in Yellowstone County. The traditional urban areas in Billings and Laurel experienced elementary enrollment decline and slow high school growth. On the other hand, the rural-suburban areas such as Custer and Broadview experienced rapid elementary growth (Custer) and/or elementary and high school (Broadview) growth.

The declining school enrollment in Musselshell County occurred despite the small net in-migration between 1990 and 2000. Most of the in-migration apparently occurred in the Klein CCD with little or no impact on the Roundup or Melstone school districts. The declining school enrollment was mostly due to the demographic structure of the population in Musselshell County. As shown in Table 3-27, the number of students in each of the lower grades is less than in the upper grades. This was caused by the declining number of births and decreasing birth rates, in the 1980s and 1990s. There are almost one-third fewer students in the 1st grade as compared to the number of students in the 12th grade (47 vs. 71). This means that even if there were no net out-migration in future years, total school enrollment would decline as the ever-decreasing classes progress through the grades.

Table 3-27 School Enrollment by Grade, Musselshell County 2000-01

Grade	Enrollment
K and Pre-K	47
1	47
2	52
3	62
4	49
5	52
6	50
7	66
8	58
9	70
10	64
11	66
12	71
Total	754

Source: Montana Office of Public Instruction, 2002.

Transportation

Maintenance and construction on U.S. Highway 12, U.S. Highway 87, and Montana Route 3 are the responsibility of the Montana Department of Transportation. The primary source of revenue

for maintaining state highways is the Montana fuel and gross vehicle weight (GVW) tax. Construction of state highways also is funded by Montana fuel taxes; however, matching federal funds account for about two-thirds of all highway construction in Montana. The Montana Department of Transportation does not attempt to justify whether or not traffic, and related fuel and GVW tax on any roadway, support the cost of maintenance or reconstruction. Furthermore, local governments do not track maintenance costs of roadways by location; therefore, operation and maintenance costs are not available for locally maintained roads. Old Divide Road is maintained by Musselshell County and is relevant as this is the route to the work site should the Project be built.

Traffic levels near the Project are low, averaging around 2,300 vehicles per day in the stretch along U.S. Route (SR 87) between the Musselshell/Yellowstone county line and the town of Klein, just south of Roundup. According to traffic counts made by the Montana Department of Transportation in Musselshell County in 1999, average daily traffic (ADT) levels were as follows:

- SR87 between the Musselshell/Yellowstone County boundary and the town of Klein 2,322 ADT
- SR87 north of Roundup 1,627 ADT
- SR12 east of Roundup 509 ADT
- SR12 west of Roundup 2,930 ADT

Data on traffic levels on Old Divide Road are not available, but as a minor rural road serving homes and ranches in the area, traffic levels on the roads would be light, probably at most in the high tens or low hundreds of vehicles per day (Jonutis, 2002).

Utilities

Municipal water for Roundup residents is obtained from two sources and then stored in two concrete reservoirs with a combined capacity of three million gallons. The primary water source originates in an abandoned coalmine on the south side of the Musselshell River. The primary source is supplemented as necessary by water directly from the Musselshell River. The present water supply is adequate for the current population. With the region entering its fifth year of drought conditions, dependence upon the Musselshell River as a supplemental water source may be in question, as rationing may be required to maintain an adequate water supply down river. In average/normal precipitation patterns, there would be more than adequate water supplies for anticipated needs.

The Roundup wastewater system has been updated to a three-cell aerated lagoon, which is underutilized. The Musselshell County Refuse District provides solid waste removal. Refuse is picked up and hauled to the Roundup transfer station where it is then hauled by a private contractor to the Billings landfill for disposal. The transfer station is operating under capacity (Gary Thomas; Waste Water Manager, City of Roundup, personal communication, January 22, 2002). Rural locations, such as the Project site, can purchase water to be delivered for cistern storage if well water is not available. Rural wastewater typically is handled by individual septic

systems. Refuse collection for rural locations is available within 50 miles of Billings. A local provider, BFI Waste Systems, can provide commercial service to the “mine site” (John Whitman, Facility Manager BFI, personal communication March 13, 2002).

Health and Safety

The Montana Highway Patrol, Musselshell and Yellowstone County Sheriff’s departments, and Billings Police Department provide Law enforcement in the affected area. The Highway Patrol concentrates on traffic patrol and traffic-related incidents, whereas the sheriff’s departments focus on criminal activity in Musselshell and Yellowstone counties.

The Musselshell County Sheriff’s Department, a consolidated city (Roundup)/County agency, provides law enforcement services for the city and county. Law enforcement personnel currently include one resident Montana Highway Patrol Officer, one Sheriff, six full time deputies, and 10 reserve deputies, five of whom are qualified to work as full deputies. Staffing generally is considered adequate at best and any increase in population would require increased staffing and infrastructure. County-wide enhanced 911 service is anticipated within the next two years. The jail is capable of holding 14 inmates, is not handicap accessible, and is considered “antiquated” (Construction on this structure was started in 1909 and completed in 1913). There have been upgrades to plumbing, electrical, and surveillance equipment. There have been discussions of merging inmate facilities with Yellowstone County (Rosalie Mercardo, dispatcher; Mark Shoup, Montana Highway Patrol; and Chuck Poulos, commissary manager; personal communication, January 22, 2002).

Fire services in Musselshell County are provided by volunteer organizations, which have adequate personal and equipment for existing needs in Roundup. However, the Bull Mountain Volunteers, a loosely organized group of local landowners who respond to the presence of smoke and phone calls, are adequately staffed but have limited firefighting equipment (nothing designed for commercial application) (Gary Thomas, City Hall, personal communication, January 22, 2002).

The Musselshell County Ambulance Service in Roundup provides on-the-ground ambulance service in the county. The service currently has two employees (one full time and one part time) and several volunteers. Three individuals are qualified at EMT- I levels, the rest are EMT Basic. They are currently responding to an average of 46 calls per month. There are three ambulances in service, one currently needs to be replaced (high mileage), and a second is scheduled for replacement in next two to three years (high mileage). Based on the current resources and the geographic challenges, the ambulance services are at the limits of acceptable response parameters. Any change in demographics would require additional staffing and response vehicles. Ideally, it would not require an ambulance and staff to be dispatched from Roundup to service the edges of the county (Ron Solberg, Director of Ambulance Services, personal communication, January 22, 2002).

Roundup Memorial Hospital is an 11-bed acute care, 37-bed long-term care facility with an average acute inpatient census of 1.3 patients per day. There are three physicians in Roundup, one optometrist, and one dentist. Courtesy privileges are extended to physicians from Billings conducting outpatient clinics (Dave McIver, Hospital Administrator, personal communication, January 18, 2002).

State, Federal, and County funding support social welfare services in Musselshell County. The County-administered welfare program provides Aid to Families with Dependent Children, Food Stamps, County Assistance (general and medical), and Medicaid. The current number of staff is not adequate to dispense the required services in a timely manner (Pam Gable, Social Worker, personal communication, January 23, 2002).

Musselshell County Mental Health Center and Musselshell Chemical Dependency Center share an office in Roundup. The Mental Health Center provides counseling to individuals with chronic mental illness. The Musselshell Chemical Dependency Center provides outpatient counseling, referrals for in-patient care and mandatory classes to driving-under-the-influence offenders. There is limited access to these services, with each available only two to three days a week (Deloris DesJarlais, Secretary, personal communication, January 28, 2002).

Social Well-Being

The social and economic character of Roundup and the area surrounding the Generation Plant site has evolved in conjunction with ranching, coal mining, and oil production. These have been the dominant sources of employment and income for Roundup area residents. Historically the economy of the Roundup area has followed a boom-and-bust pattern, starting with the cattle industry in the 1880s and extending through the coal mining and oil development periods. Many area residents' social values, perceptions, and lifestyles have been influenced by the cyclical nature of good economic times followed by recession. Though residents of the area have experience with boom-and-bust cycles, they have not been inured to the disruptive effects these cycles have.

The ways in which people identify and respond to one another in Roundup are typical of small western towns—informal and personal. Residents know almost everyone in town and are aware of individuals' character, occupation, and socioeconomic status. They can also be very suspicious of outsiders. Residents value the small town atmosphere, the quiet and predictable pace of life, and mutually supportive networks of family and friends.

Communities such as Roundup develop unique rhythms and tempos, because of their predictable and supportive lifestyles. People know when to do things—stores open during certain hours; there are slack times and busy times; they know where and how to find people they might need or wish to see; they know how things are expected to be done; they know who is who and how and when to speak to whom. An influx of people who do not “know the ropes,” the local ways and lore, is disruptive to these patterns. Rhythms and tempos change and long-time residents are forced to re-adjust to when and how to do things. New norms and values challenge the old ways of doing things. Economic development can increase the income and wealth of residents, both new and old, and disrupt the social status structure of pre-development times.

Rapid social change that is characteristic of development “boom” periods brings with it qualitative change to the composition of local populations, as migrants arrive from a wide array of origins, with a wide array of socio-cultural backgrounds. The quantitative and qualitative population changes result in a variety of changes that can disrupt established social patterns. Ensuing problems have been found to include increases in divorce and broken homes (Mudock et al., 1980, Cortese and Jones, 1977, Hardt, 1994).

Reflective of social status disruptions, in recent years the Bull Mountains area has experienced an influx of people seeking the seclusion, scenery, and relatively pristine natural surroundings of the area. Many Roundup residents have termed these newcomers “mini-farmers” because they have purchased small acreages and have small numbers of livestock. It is perceived by Roundup residents that Bull Mountain area residents are becoming somewhat of a social, political, and economic influence because they are organizing to reflect their specific interests, such as the Bull Mountains Landowners Association and Bull Mountain Volunteers.

The effects of proposed development on the social life of Roundup and Bull Mountains residents are apparent within the area. Some people have become polarized based on their support for or opposition to the mining development and the strains may extend to the Generation Plant. Roundup residents tend to favor new coal development, whereas the ranchers and Bull Mountain “mini-farmers” are perceived by Roundup residents to oppose it. Social interaction between the “pro” and “anti” factions has become strained because of the relatively high degree of emotion associated with coal development (Northwest Economic Consultants, 1989). Factional strains are likely to persist, at least in the near term, regardless of whether the proposed development goes forward. If it does go forward the “anti” faction would likely blame the “pro” faction for any problems that emerge, whether these were pre-existing or not or whether the problems are associated with the development. If the development does not go forward, the “pro” faction would likely blame the “anti” faction for being responsible for the lost opportunity and the social and economic benefits that might have come with the new coal development. In this respect, the social impact of the mining development has already occurred and likely would persist for some time, regardless of the outcome of the issue.

CHAPTER 4

ENVIRONMENTAL CONSEQUENCES

4.1 Introduction

The purpose of this chapter is to describe adverse and beneficial impacts of the Proposed Action and Alternatives on the affected environment as described in Chapter 3. The Proposed Action would grant an Air Quality Permit for the proposed Roundup Power Project (Project). The Project includes a coal-fired Generation Plant, a conveyance system for acquiring coal from the nearby Bull Mountains Mine (Mine), a 28-mile 161kV Transmission System, and associated access roads that would have to be built or upgraded to construct and maintain the Project facilities.

Alternatives to the Project are described in detail in Chapter 2 and include 1) Alternative Landfill and 2) a 230kV Transmission System. The Alternative Landfill calls for storing the Generation Plant waste ash in permanent landfill sites on and adjacent to the plant site for the life of the plant. Methods associated with the Proposed Action call for storing waste ash in a landfill on the plant site for 10 years and the Mine for the remaining 30 years identified as the life of the Project.

The 230kV Transmission System Alternative would utilize 230kV circuits instead of the proposed 161kV circuits for the transmission of power from the Generation Plant to the Broadview Substation.

4.1.1 Impact Assessment Methods

This chapter evaluates the direct and indirect impacts that may result from the Project and the alternatives. The nature and area of these potential impacts are described in detail later in this chapter.

Where potential impacts to a resource were identified, an evaluation was conducted to determine if one or more actions would be effective in avoiding or reducing (e.g. intensity and/or duration) the potential impact. The Project was designed to include mitigation measures to avoid or minimize impacts of the Project. Refer to Chapter 2 for a list of these measures. Mitigation measures were categorized as 1) mitigation that may be required in a permit or license without the Project proponent's consent and 2) recommended mitigation that can be made a permit or license condition only with the Project proponent's consent. Mitigation measures that are not associated with a permit or license cannot be enforced as part of this MEPA process unless the Project proponent agrees to have them made permit conditions and are recommended by the DEQ for further reduction in impacts associated with this Project. Mitigation measures are discussed for each resource.

Impact assessments were conducted for the Proposed Project and Alternatives. Criteria for determining the level of impacts are stated for each resource. Irreversible and irretrievable

commitments of resources that would be involved in the Project are presented in Section 4-13. Cumulative effects are to be described in Section 4-14.

Cumulative impacts are identified only where there is a reasonable likelihood that the Project would have a cumulative effect with consideration of other past or present actions or future actions which are under concurrent consideration by DEQ (or another state agency) through pre-impact statement studies, separate impact statement, or permit –processing procedures.

4.2 Air Resources

The emission of air pollutants is regulated under both federal and Montana State laws and regulations. The federal Clean Air Act (CAA) and the subsequent Clean Air Act Amendments of 1990 (CAAA) require the Environmental Protection Agency (EPA) to establish National Ambient Air Quality Standards (NAAQS) to protect public health and welfare.

The CAA and CAAA established NAAQS for pollutants known as “criteria” pollutants. Primary NAAQS and Montana Ambient Air Quality Standards (MAAQS) are established at a level designed to protect public health with an adequate margin of safety. Secondary NAAQS have also been defined, “based on criteria requisite to protect the public welfare from any known or anticipated adverse effects associated with the presence of [the] pollutant in the ambient air.”

In addition to the MAAQS and NAAQS, an additional level of air quality protection for the Project would be provided by the requirements of the Prevention of Significant Deterioration (PSD) program. The PSD regulations set “PSD Increments,” which are maximum allowable increases above a baseline ambient concentration. The PSD Increments range from 20% to 40% of the NAAQS for each pollutant and averaging period.

Increases in ambient pollutant concentrations are not considered to cause significant adverse impacts, if they do not exceed any applicable MAAQS, NAAQS, or PSD Increment.

As part of the CAAA, Congress also adopted a program for control of air toxics (also known as hazardous air pollutants [HAPs]). Congress designated 188 individual HAPs for control through development of National Emissions Standards for Hazardous Air Pollutants (NESHAP). These NESHAP standards have taken the form of Maximum Achievable Control Technology (MACT) requirements for emission source categories. As the MACT requirements are promulgated by EPA, Montana has incorporated them by reference into ARM 17.8.302. The MACT establishes HAP emissions limits and/or monitoring and emissions control technology requirements for an emissions source category (i.e., generation plants).

4.2.1 Methods

Impacts from the Project facility on air quality were assessed using emission rate data, emission point parameters (e.g., stack temperature, stack exhaust flow rate, etc.) and local meteorological (met) data together with computer models to predict the pollutant-specific and site-specific impacts for each pollutant. Specifically, the Industrial Source Complex (ISC3) and CALPUFF (this is a puff model originally developed for the California Air Resources Board and it is not an acronym) dispersion models were used to predict impacts.

Impacts from greenhouse gas emissions were assessed using source-specific emission rates for greenhouse gases. Equations developed by the Intergovernmental Panel on Climate Change (IPCC) were used to assess the global warming potential (GWP) of the Project facility emissions.

Information obtained from the Supplemental EIS Support Document (Bull Mountain Development Co., LLC, 2002a) was used as background in creating the air resources analysis.

Impact Criteria

Ambient and Increment Analysis Criteria

The PSD modeling significance levels, PSD monitoring *de minimis* levels, PSD increments, NAAQS, and MAAQS can be found in the Code of Federal Regulations (CFR) and the Administrative Rules of Montana (ARM) Title 17, Chapter 8. The PSD increments are further broken down into either Class I or Class II increments depending on the classification of the impact area of concern. A Class I area is held to more stringent standards than a Class II area. Table 4-1 summarizes the PSD modeling significance levels, PSD monitoring *de minimis* levels, PSD Class I and II increments, and NAAQS/MAAQS that are applicable to the Project facility.

Impacts that exceed the NAAQS/MAAQS and/or PSD increments are classified in this document as high and could lead to a decision to reject a permit application by either DEQ or EPA.

Impacts above the PSD modeling significance levels are classified in this document as moderate and require a cumulative ambient and increment modeling analysis. The PSD modeling significance levels in Table 4-1 apply to PSD Class II areas. For Class I areas, EPA has suggested significant impact levels (SILs) should be set equal to 4% of the respective Class I PSD increment. This approach for Class I areas is widely used in modeling analyses, but has not been formally adopted by EPA.

Impacts that are below NAAQS/MAAQS and Class II PSD increments are classified in this document as low and negligible by DEQ and EPA regulations.

Table 4-1 National and Montana Ambient Air Quality Standards, PSD Increments and PSD Significance Levels

Pollutant	Average Period	NAAQS ($\mu\text{g}/\text{m}^3$)	MAAQS ($\mu\text{g}/\text{m}^3$)	PSD Class I Increment ($\mu\text{g}/\text{m}^3$)	PSD Class II Increment ($\mu\text{g}/\text{m}^3$)	PSD Modeling Significance Level ($\mu\text{g}/\text{m}^3$) ^a	PSD Monitoring De Minimis Levels ($\mu\text{g}/\text{m}^3$) ^a
NO ₂	Annual	100	94	2.5	25	1	14
	1-hour ^b	--	564	--	--	--	--
SO ₂	Annual	80	52	2	20	1	--
	24-hour ^b	365	262	5	91	5	13
	3-hour ^b	1,300	--	25	512	25	--
	1-hour ^c	--	1,300	--	--	--	--
CO	8-hour ^b	10,000	10,350	--	--	500	575

Pollutant	Average Period	NAAQS ($\mu\text{g}/\text{m}^3$)	MAAQS ($\mu\text{g}/\text{m}^3$)	PSD Class I Increment ($\mu\text{g}/\text{m}^3$)	PSD Class II Increment ($\mu\text{g}/\text{m}^3$)	PSD Modeling Significance Level ($\mu\text{g}/\text{m}^3$) ^a	PSD Monitoring De Minimis Levels ($\mu\text{g}/\text{m}^3$) ^a
PM ₁₀	1-hour ^b	40,000	26,450	--	--	2,000	--
	Annual	50	50	4	17	1	--
	24-hour ^b	150	150	8	30	5	10
Ozone ^d	1-hour	235	196	--	--	--	100 tpy ^c
Lead	Calendar Quarter	1.5	1.5	--	--	--	0.1 ^f

Source: Administrative Rules of Montana, Title 17, Chapter 8, Sub-chapter 2, Ambient Air Quality, 1996; Title 40 Code of Federal Regulations Part 50, National Primary and Secondary Ambient Air Quality Standards, Revised July 2002; EPA, Office of Air Quality Planning and Standards, New Source Review Workshop Manual (Draft) October, 1990.

^aBased on High 1st High Impact

^bBased on High 2nd High Impact

^cBased on High 19th High Impact

^dEmission of VOCs

^eIf facility's VOC emissions are 100 tpy or greater then ozone monitoring is required

^fBased on a 24-hr average

AQRV Analysis Criteria

Significance criteria are also established for impacts to air quality-related values (AQRV) in Class I areas. The impacts on Class I AQRV that were assessed for the Project facility included visibility impacts; acid deposition impacts; and impacts to soils, plants, and animals.

Table 4-2 summarizes the significance levels that Federal Land Managers (FLM) use for visibility and acid deposition (acid rain) impacts. These values are obtained from the Federal Land Managers Air Quality Related Values Workgroup (FLAG) – Phase I Report (US Forest Service et al., 2000) and the report titled, Guidance on Nitrogen and Sulfur Deposition Analysis Thresholds (US Forest Service et al., 2002a), respectively. These documents are not state or federal regulations but guidance prepared by the FLMs, which they use in a determination of potential adverse effects.

Table 4-2 Class I Visibility and Acid Deposition Significance Levels

Analysis	Parameter	Levels of Concern
Visibility	Change in Light Extinction	0.4% (de minimis level)
		5% (triggers cumulative analysis)
		10% (may indicate an adverse impact)
Acid Deposition	Nitrogen Flux	0.005 kg/ha/yr
	Sulfur Flux	0.005 kg/ha/yr

Sources: U.S. Forest Service, National Park Service and U.S. Fish and Wildlife Service, "Federal Land Managers Air Quality Related Values Workgroup (FLAG) Phase I Report", December, 2000, "Guidance on Nitrogen and Sulfur Deposition Analysis Thresholds", 2002.

Visibility impacts are measured by the change in atmospheric light extinction relative to natural background conditions. A change in extinction is calculated as a 24-hour average per calendar day. An “Adverse Impact on Visibility” is defined in the FLAG guidance document (FLAG, 2000) on page 152 and in Chapter 8, Glossary of this report.

For modeled visibility impacts, a predicted change in extinction less than 0.4% due to emissions from the proposed facility would be considered below *de minimis* and would not require further analysis. Therefore, predicted impacts from a facility that are below 0.4% are classified in this document as low and negligible. A predicted change in extinction less than 5% due to emissions from a proposed facility would likely not trigger an FLM objection to the air quality permit. Therefore, predicted impacts from a proposed facility below 5% would be classified in this document as low. Model-predicted impacts for the facility between 5 and 10% are classified in this document as moderate, and a cumulative analysis would be expected to be performed for the Class I area of concern. If a change in extinction due to emissions from the facility is predicted to be greater than 10%, the FLM would likely raise objections to the pollutant loading without mitigation of the source. These impacts are classified in this document as high and may result in a finding of adverse impact by the FLM.

Cumulative model-predicted impacts above 10% are also classified in this document as high but not necessarily unacceptable by the FLM. In this case, the FLM makes an acceptability determination based on whether the facility’s contributions are *de minimis* (<0.4%) on the days when cumulative impacts are above 10%. Adverse visibility impacts are typically determined by the FLM on a case-by-case basis for the Class I area of concern. Depending upon the FLM finding on visibility impacts and their review of the application, DEQ makes a finding whether the facility would “cause or contribute to adverse impact on visibility within any federal Class I area” (ARM 17.8.1106). This finding determines whether DEQ will issue the air quality permit.

Deposition-induced changes to AQRVs are of serious concern to FLMs. Deposition analysis thresholds (DAT) have been established and are intended to distinguish where deposition increases may result in potentially adverse ecosystem stresses, as well as where deposition increases are likely to have a negligible impact on AQRVs. The DAT is a screening threshold, not necessarily an adverse impact threshold. The DAT defines the additional amount of deposition that triggers a management concern, not necessarily the amount that constitutes an adverse impact to the environment. Adverse impact determinations are typically determined on a case-by-case basis for modeled deposition values that are higher than the DAT. The DAT for Western U.S. Class I areas for both south and north is set at 0.005 kilograms per hectare per year (kg/ha/yr) (NPS and USFWS, 2002). Model-predicted impacts of acid deposition below the DAT are classified in this document as low. Model-predicted impacts between a 0.005 kg/ha/yr and 0.125 kg/ha/yr are classified in this document as moderate, and a cumulative analysis would be required by the FLM. Model-predicted impacts above 0.125 kg/ha/yr would be classified in this document as high and potentially unacceptable by the FLM.

Other impacts to AQRV include impacts to plants, soils, and animals. The screening document, (EPA Office of Air Quality Standards, 1980), provides screening values for effects of gaseous criteria pollutants on vegetation and for effects of trace metals on soils, plants, and animals. The screening levels provided are not necessarily safe levels or levels above which concentrations would necessarily cause harm in a particular situation. They are minimum levels at which adverse effects have been reported. If impacts are above the screening levels, then the source

might have adverse impacts on plants, soils, and animals and appropriate action would have to be taken by the FLM (EPA, 1980). Model-predicted impacts below these screening levels are classified in this document as low. Model-predicted impacts above these screening levels are classified in this document as high. The numerous screening values are provided in the screening document. The nature of screening is to identify impacts. There are no definable moderate boundaries, it is either below the screen level and considered low, or it is above the screen level and considered high.

No specific significance criteria are available for assessing the greenhouse gas emission impacts on global warming. There is still much debate about how much impact emissions from stationary sources have on global warming. Therefore, for this EIS, no impact levels are established.

4.2.2 Proposed Action

Generation Plant

A detailed evaluation of the air impacts from the Project was included in the PSD air quality permit application submitted to the Montana Department of Environmental Quality (DEQ) in January 2002 for this Project and in supplemental data submitted through July 2002 as part of the permitting process. The methods used and results obtained from the air quality impact analyses are summarized in the following sections.

Air Contaminant Emission Rates

Air contaminant emissions from combustion sources at the Project would include the following criteria air pollutants: NO₂, SO₂, CO, PM₁₀, and VOC. The facility would also emit HAPs, including mercury, HCl, and lead. Lead is regulated as both a criteria air pollutant and a HAP (lead compounds).

Fugitive PM and PM₁₀ (“dust”) emission sources associated with the proposed facility include vehicle travel on unpaved roads, construction activities, material handling (coal, ash [bottom and fly], and lime), and wind erosion of storage piles and disturbed areas. During construction of the generation plant, fugitive dust would result from heavy construction equipment operations, travel on unpaved roads, disturbance of soils, and general construction activities. Dust emissions would be mitigated through the application of water and restriction of vehicle speeds. Once the plant is operational, fugitive dust emissions at the facility would be primarily material handling activities, vehicle traffic on unpaved roads, and wind erosion.

Table 4-3 summarizes the maximum potential plant-wide emission rates for criteria pollutants and HAPs. A detailed breakdown of the emission totals, by source category, is presented in the air quality permit.

Table 4-3 Plant-Wide Source Emission Summary

Source	PM ₁₀		SO ₂		Pb		NO ₂		VOC		CO		HAPs	
	lb/hr	tpy	lb/hr	tpy	lb/hr	tpy	lb/hr	tpy	lb/hr	tpy	lb/hr	tpy	lb/hr	tpy
Main	120	491	964	3928	0.04	0.2	562	2291	24	99	1204	4910	21	90.2

Source	PM ₁₀		SO ₂		Pb		NO ₂		VOC		CO		HAPs	
	lb/hr	tpy	lb/hr	tpy	lb/hr	tpy	lb/hr	tpy	lb/hr	tpy	lb/hr	tpy	lb/hr	tpy
boilers														
Other combustion	3.8	2.8	21	11	0.004	0.002	128	38	1.4	0.5	9	7	0.4	0.3
Material handling	--	15	--	--	--	--	--	--	--	--	--	--	--	--
Fugitive	--	3.6	--	--	--	--	--	--	--	0.02	--	--	--	--
Totals	124	512	985	3939	0.04	0.2	690	2329	25.4	99.5	1213	4917	21.4	90.5

Source: Bull Mountain Development Company, LLC, 2002a.

The HAP emissions reported in Table 4-3 can be further broken down into specific HAPs. Table 4-4 presents individual HAP emissions estimates for the two coal-fired boilers (Bull Mountain Development Company, LLC., 2002b). Because individual HAP emissions for HCl exceed the 10-tons/year threshold, and because total HAP emissions for each boiler exceed the 25 tons/year threshold, the Project would be considered a major source of HAPs. Total mercury emissions are projected at 0.110 tons/year for both boilers.

Table 4-4 Boiler HAP Emission Inventory

HAP	Emission Rate Per Main Boiler		Emission Rate for Both Boilers	
	lbs/hr	tpy	lbs/hr	tpy
Antimony	0.001	0.004	0.002	0.008
Arsenic	0.004	0.017	0.008	0.034
Asbestos	0.000	0.000	0.0	0.0
Beryllium	0.000	0.001	0.0	0.002
Cadmium	0.003	0.011	0.006	0.022
Chromium	0.011	0.049	0.022	0.098
Cobalt	0.003	0.015	0.006	0.030
Hydrogen Fluoride	1.272	5.572	2.544	11.144
Hydrogen Chloride	6.903	30.236	13.806	60.472
Manganese	0.031	0.137	0.062	0.274
Mercury	0.013	0.055	0.026	0.110
Nickel	0.011	0.048	0.022	0.096
Selenium	0.134	0.588	0.268	1.176

HAP	Emission Rate Per Main Boiler		Emission Rate for Both Boilers	
	lbs/hr	tpy	lbs/hr	tpy
Lead	0.013	0.059	0.026	0.118
PCDD/PCDF ^a	1.48e-04	6.47e-04	2.96e-04	1.29e-03
PAH ^b	4.20e-03	1.84e-02	8.40e03	3.68e-02
Other organic compounds ^c	1.856	8.128	3.712	16.256
Total	10.3	44.9	20.5	89.8

Source: Bull Mountain Development Company, LLC., 2002b

^a Polychlorinated Dibenzo-P-Dioxins and Polychlorinated Dibenzofurans

^b Polynuclear Aromatic Hydrocarbons listed in Table 1.1-13, (AP-42, 1998)

^c Organic compounds listed in Table 1.1-14, (AP-42, 1998)

Air Pollutant Control Technologies

BACT Analysis

Federal and state regulations require that the Best Available Control Technology (BACT) be employed on each emitting unit at the facility. BACT is a case-by-case determination that is developed based on a balance between technical and economic feasibility and potential environmental impacts of the control alternatives. A BACT analysis utilizes a top-down approach. First, all of the control technologies for the pollutant of concern are listed by control efficiency with the highest control listed first. Second, the control technologies are eliminated based on economic and/or technical infeasibilities. Third, the remaining control technologies are then evaluated based on potential adverse environmental impacts. Those associated with unacceptable impacts are eliminated. Finally, the remaining technology with the highest control efficiency is chosen as BACT.

Under PSD regulations, the proposed facility is required to prepare a BACT analysis for each pollutant that would be emitted at a rate greater than or equal to the significant annual emission rate specified in the regulations. This section provides an overview of the BACT analysis for the two main coal-fired boilers. A detailed discussion of each of the BACT technologies is provided in the air quality permit application.

The BACT analysis for the main boilers addressed the criteria pollutants and sulfuric acid mist (H₂SO₄). Table 4-5 lists the BACT technologies considered for the main boilers.

Table 4-5 Review of BACT Analysis

Pollutant	BACT Considered	Comments
NO _x	Low NO _x Burners and Overfire Air (LNB/OFA)	Controls the stoichiometry and temperature of the combustion flame
	Flue Gas Recirculation (FGR)	Generally used in natural gas-fired units

	Selective Non-Catalytic Reduction (SNCR)	Direct injection of ammonia or urea into the flue gas
	Selective Catalytic Reduction (SCR)	Injection of ammonia into the flue gas in the presence of a catalyst
Particulate Matter	Electrostatic Precipitators (ESPs)	Removes particulate from the flue gas by charging particles and attracting them to charged collection plates
	Fabric Filters (FF)	Fabric bags act as filters to collect particulate matter
Sulfur Dioxide	Fuel Switching	Controlling the amount of sulfur in the combusted coal
	Wet Scrubbing (wet FGD)	Lime or limestone slurry used to remove SO ₂ from the flue gas
	Dry Flue Gas Desulfurization (dry FGD)	A lime reagent applied to the combustion gases
Carbon Monoxide	Catalytic Oxidation	No history of use on a coal-fired generation plant
	Thermal Oxidation	No history of use on a coal-fired generation plant
	Proper Boiler Design and Operation	Minimizes the formation of CO
VOCs	Proper Boiler Design and Operation	Minimizes VOC emissions
Sulfuric Acid Mist	Wet Scrubbing (wet FGD)	Approx. 25% control of H ₂ SO ₄
	Wet FGD with wet ESP	ESP provides an additional 90% control of H ₂ SO ₄
	Dry Flue Gas Desulfurization (dry FGD)	Approx. 90% control of H ₂ SO ₄

Source: Bull Mountain Development Company, LLC., 2002b

Table 4-6 lists the BACT technologies proposed for the Project and, for the main boilers only, the proposed emission limits for each pollutant in pounds per hour (lbs/hr). Emission limits for all other sources can be found in the Project's draft air quality permit (see Appendix A).

Table 4-6 Proposed BACT Emission Limits and Control Technologies

Pollutant	Emission Limit Based on Following Criteria (lbs/MMBtu)	Proposed Emission Limit (lbs/hr)	Proposed BACT
NO _x (Main Boilers)	0.07 lb/MMBtu	262 (30-day rolling average)	LNB/OFA and SCR
PM ₁₀ (Main Boilers)	0.015 lb/MMBtu	56.1	Fabric Filter

Pollutant	Emission Limit Based on Following Criteria (lbs/MMBtu)	Proposed Emission Limit (lbs/hr)	Proposed BACT
SO ₂ (Main Boilers)	0.12 lb/MMBtu	448.4 (30-day rolling average)	Dry Flue Gas Desulfurization
CO (Main Boilers)	0.15 lb/MMBtu	560.6	Proper Boiler Design and Operation
VOC (Main Boilers)	0.0030 lb/MMBtu	11.2	Proper Boiler Design and Operation
Sulfuric Acid Mist (Main Boilers)	--	--	Dry Flue Gas Desulfurization
PM ₁₀ (Material Handling)	—	—	Transfer Points: Spray Dust Suppression/Enclosed Transfer Points and Baghouses Storage Piles: Windbreak Fence and Spray Dust Suppression
Auxiliary Boilers	—	—	Low NOx Burners, low sulfur No. 2 fuel oil, and maximum of 3,300 hours/year operation
Emergency Diesel Generator	—	—	Low sulfur No. 2 fuel oil and maximum of 200 hours/year operation

Source: DEQ Preliminary Determination on Permit Application, Permit #3182-00, 2002b

MACT Analysis

Federal and state regulations require that Maximum Achievable Control Technology (MACT) be applied to emitting units (source categories) that are major sources of hazardous air pollutants (HAPs). MACT is a defined set of emissions limits, monitoring and/or control technologies to be applied to each source category. EPA has established MACT requirements for many source categories. However, for generation plants, the CAAA required that EPA study the public health effects of air toxic emissions from utilities that burn fossil fuels (coal, oil and natural gas) and determine whether it is necessary to regulate those emissions (EPA, 2000). EPA has completed their study, reported to Congress, and recommended “regulation of HAP emissions from coal- and oil-fired electric utility steam generating units under Section 112 of the Clean Air Act is appropriate and necessary” (65 FR 79826). EPA further indicated in a December 14, 2000, Fact Sheet that it would propose regulations for emissions of air toxics from coal- and oil-fired generation plants by December 15, 2003, and issue final regulations by December 15, 2004 (EPA, 2000).

In the situation where a MACT is required, but not yet promulgated, the CAAA requires a case-by-case MACT analysis for a new or reconstructed major source. The Project falls into this

category by virtue of being a major source of HAPs and being subject to EPA’s finding that regulation of HAP emissions from coal- and oil-fired electric utility steam generating units is appropriate and necessary.

As a major source of HAPs, MACT must be implemented for the two coal-fired boilers. A case-by-case MACT analysis for the main boilers was submitted to DEQ as part of the air quality permit application. As shown in Table 4-7, the design and operation of the boiler combustion systems, along with the planned criteria pollutant control systems (selective catalytic reduction, dry FGD, and fabric filters), are effective in controlling HAPs. The Proponent has proposed that these technologies are the appropriate MACT determination for the Generation Plant and they have proposed that the BACT emissions limits would serve to monitor compliance with MACT requirements.

Table 4-7 Proposed MACT Technology

HAP Category	MACT Technology	Compliance Determination
Acid Gases	Spray Dryer Absorber (SDA)	Compliance with SO ₂ BACT limit
Trace Metals	Fabric Filter	Compliance with PM ₁₀ BACT limit
Radionuclides	Fabric Filter	Compliance with PM ₁₀ BACT limit
Organic Compounds	Combustion Controls	Compliance with CO and VOC BACT limits

Source: Bull Mountain Development Company, LLC., 2002b

The addition of powdered activated carbon (PAC) for mercury control was also considered in the case-by-case MACT analysis for the Project. A technical paper evaluating mercury controls for generation plants was presented in the Journal of the Air and Waste Management Association titled “Preliminary Estimates of Performance and Cost of Mercury Control Technology Applications on Electric Utility Boilers” (Srivastava, et al., 2001). This paper indicates that control technologies using injection of PAC into the flue gas appear to hold promise for reducing mercury emissions from utility boilers. However, the paper states, “because data are not available on mercury control technology applications involving ... boilers firing bituminous coals and using fabric filters (FF), PAC injection rate algorithms could not be developed for these applications.” Moreover, the paper concludes that “the performance and cost estimates of the PAC injection-based mercury control technologies presented in this paper are based on relatively few data points from pilot scale tests, and are therefore considered preliminary.” Ongoing research efforts are anticipated to address the remaining questions regarding application of mercury controls.

While this research is being conducted, EPA provides a perspective on use of criteria pollutant devices for HAPs control. In a *Federal Register* notice on HAP emissions from generation plants, EPA states, “bituminous coals contain higher concentrations of chlorine and other constituents that promote the oxidation and capture of mercury in conventional pollution control devices” (65 FR 79828). They further state, “dry scrubbers which employ a spray dryer absorber (SDA) in conjunction with an ESP or FF are typically very effective in reducing HAP emissions.

Some coal-fired utilities that use bituminous coal in pulverized coal-fired units have shown mercury capture in excess of 90 percent in SDA/FF systems” (65 FR 79829). EPA would be considering this information as well as the results of ongoing research in preparing a MACT standard for generation plants. The Project would likely be subject to the generation plant MACT standards when they are promulgated.

Air Dispersion Modeling Impacts from the Facility

Air dispersion modeling has been performed to determine the radius of impact of plant emissions from the Project. First, the emissions of NO_x, SO₂, CO, and PM₁₀ have been modeled and impacts compared to the PSD modeling significance levels. Based on these results, the radius of impact is established. PSD modeling significance levels have not been established for PM, VOC, or any of the HAPs (i.e., lead, sulfuric acid mist, fluorides, reduced sulfur compounds, and total reduced sulfur) (EPA, 2002, A.R.M.17.8.8, 1996).

Radius of Impact

The radius of impact is the geographic area where the modeled impacts from the plant exceed PSD modeling significance levels contained in the PSD regulations. Modeling significance levels are regulatory impact levels that trigger cumulative analyses, but do not necessarily indicate adverse environmental effects. The size of the Project’s radius of impact is pollutant- and averaging-time specific. The modeling receptor network used for cumulative analyses must extend outward as far as necessary to include all receptors whose values equal or exceed the PSD modeling significance levels. Once the most distant "significant" modeling receptor was identified, ambient and PSD analyses were completed for all receptors within the circle drawn around this receptor. Once the radius of impact was established, all minor sources within the radius of impact and all major sources within the radius of impact and 50 km past the radius of impact were included in a cumulative NAAQS/MAAQs and PSD increment dispersion modeling analysis (EPA, 1990). The cumulative NAAQS/MAAQs analysis is presented in Section 4.14.

The modeling results from this radius of impact analysis were also compared to the MAAQS/NAAQS and PSD Class II increments to make sure that the Project, by itself, did not cause a violation of the MAAQS/NAAQS or PSD Class II increment. No Class I area is within the radius of impact; therefore, impacts from this analysis were not compared to the PSD Class I increment.

Modeled Receptors

Model coordinates for the sources and the receptors are expressed as Universal Transverse Mercator (UTM) coordinates, with the elevations obtained from digitized (USGS) maps otherwise known as digitized terrain data (DTD). Beeline-Software created a DTD map that encompasses the entire impact area and beyond to 100 km in all directions. The DTD map is created with high resolution 7.5 minute USGS quadrangle maps out to 50 km in all directions and USGS 3 arc-second data out from 50 to 100 km in all directions.

The ambient air property boundary for the Project is the site fenceline. Modeling receptors were placed at 50-meter intervals along the fenceline, and Cartesian grid receptors were used for the remainder of the modeling as listed below:

- 100-meter spacing from fenceline to 2,000 meters,
- 500-meter spacing from 2,000 meters to 10,000 meters,
- 1000-meter spacing from 10,000 meters to 50,000 meters, and
- Individual receptors at identified house sites in the area.

Refined receptor grids were used around points of peak model-predicted impact (hotspots) with a spacing of 10 meters. Several hotspot receptor grids were developed for each pollutant and averaging time (Bull Mountain Development Company, LLC., 2002b).

Meteorological Data

Five years of meteorological (met) data from 1987-1991 were used for the modeling demonstration. The data are from the National Weather Service (NWS) station at the Billings airport, located approximately 35 miles south of the site. The Billings data are considered representative for the Project site due to nearby location and similar wind patterns. The NWS met data were processed using the latest version of EPA’s PCRAMMET preprocessor program. A windrose of five years of Billings met data (Figure 3-1) can be found in Chapter 3.

Project Source Parameters

All of the proposed sources at the Project are included in the modeling. Gaseous pollutants are emitted from fuel combustion in the two main boilers, the two auxiliary boilers, and the emergency generator. Gaseous tailpipe emissions from vehicles were not modeled. Particulate emission sources include the combustion sources, material handling system vents and baghouses, fugitive emissions from the coal pile loading and coal handling, windborne emissions from the active and inactive coal piles, and vehicle road dust.

Annual impacts were predicted based on the proposed annual operating limits for individual sources. Short-term impacts for all pollutants were predicted based on maximum hourly emissions from each source. Emissions from all of the equipment, including the auxiliary boilers and the emergency generator, were modeled on coincident peak to determine the worst-case short-term impacts. Table 4-8 summarizes the modeled parameters for each point source at the Project. Fugitive emissions sources were not included in Table 4-8 because they are too numerous to list and relatively small in nature compared to the point sources (Bull Mountain Development Company, LLC., 2002b).

Table 4-8 Modeling Parameters and Emission Rates for Roundup Power Project Point Sources

Point Sources	Stack Height (ft)	Stack Velocity (fps)	Stack Diameter (ft)	Stack Temp. (F)	Emission Rate Averaging Period	NOx Emission Rate (lbs/hr)	PM ₁₀ Emission Rate (lbs/hr)	SO ₂ Emission Rate (lbs/hr)	CO Emission Rate (lbs/hr)
Main Boiler #1	574	100	17.1	180	Hourly	281.0 ^a	60.0 ^a	482.0 ^a	602 ^a
					Annual	261.2 ^{b, c}	56.1 ^{b, c}	448.4 ^{b, c}	
Main	574	100	17.1	180	Hourly	281.0 ^a	60.0 ^a	482.0 ^a	602 ^a

Point Sources	Stack Height (ft)	Stack Velocity (fps)	Stack Diameter (ft)	Stack Temp. (F)	Emission Rate Averaging Period	NOx Emission Rate (lbs/hr)	PM ₁₀ Emission Rate (lbs/hr)	SO ₂ Emission Rate (lbs/hr)	CO Emission Rate (lbs/hr)
Boiler #2					Annual	261.2 ^{b, c}	56.1 ^{b, c}	448.4 ^{b, c}	
Auxiliary Boiler #1	260	85	3.5	500	Hourly Annual	19.77 ^{a, c} 3.79 ^b	1.65 ^{a, c} 0.32 ^b	6.47 ^{a, c} 1.24 ^b	4.12 ^a
Auxiliary Boiler #2	260	85	3.5	500	Hourly Annual	19.77 ^{a, c} 3.79 ^b	1.65 ^{a, c} 0.32 ^b	6.47 ^{a, c} 1.24 ^b	4.12 ^a
Backup Generator	44	132	3.9	224	Hourly Annual	44.22 ^a 1.01 ^b	0.52 ^a 0.02 ^b	0.80 ^a 0.02 ^b	0.95 ^a

Source: Bull Mountain Development Company, LLC., 2002b

NOTE:

^a Worst-case hourly emission rate used for short-term impacts obtained from modeling files submitted with air quality permit application

^b Annual emission rate used for annual impacts obtained from modeling files submitted with air quality permit application

^c Emission rate limit obtained from Preliminary Draft Air Quality Permit

Modeling Results

The modeling results presented in this section were used to establish the radius of impact, to determine premonitoring requirements for each pollutant, and to demonstrate that the proposed Project, by itself, would not cause a violation of any NAAQS, MAAQS, or PSD Class II Increment.

Identification of Radius of Impact

Table 4-9 lists the radius of impact modeling results for the Project. The table lists the distance, in miles, to the farthest point (i.e., receptor) at which the radius of impact level is reached. The largest identified radius of impact is 8.1 miles for the SO₂ 24-hour averaging period (Bull Mountain Development Company LLC., 2002b). The radius of impact does not extend to the Billings/Laurel area. Therefore, the radius of impact would not extend into any non-attainment area. The results presented in the table also show that Project, by itself, does not cause a violation of the NAAQS/MAAQS. (See Table 4-1 for NAAQS/MAAQS and Class II increment.)

Table 4-9 Radius of Impact Analysis Results

Pollutant	Parameter	1-Hour	3-Hour	8-Hour	24-Hour	Annual
SO ₂	Modeling Impact (µg/m ³)	107.6	53.8	--	19.2	2.4
	PSD Modeling Significance Levels (µg/m ³)	--	25	--	5	1
	Radius of Impact (miles)	7.4 ^b	6.8	---	8.1	6.2
NO ₂ ^c	Modeling Impact (µg/m ³)	--	--	--	--	1.4

Pollutant	Parameter	1-Hour	3-Hour	8-Hour	24-Hour	Annual
	PSD Modeling Significance Levels ($\mu\text{g}/\text{m}^3$)	--	--	--	--	1
	Radius of Impact (miles)	---	---	---	---	4.5
PM ₁₀	Modeling Impact ($\mu\text{g}/\text{m}^3$)	--	--	--	19.6	1.7
	PSD Modeling Significance Levels ($\mu\text{g}/\text{m}^3$)	--	--	--	5	1
	Radius of Impact (miles)	---	---	---	1.5	0.4
CO	Modeling Impact ($\mu\text{g}/\text{m}^3$)	132.8	--	35.6	--	--
	PSD Modeling Significance Levels ($\mu\text{g}/\text{m}^3$)	2,000	--	500	--	--
	Radius of Impact (miles)	None	---	None	---	---

Source: Bull Mountain Development Company, LLC., 2002b

^aFrom modeling files submitted with air quality permit application

^bBased on Montana 1-hour standard

^cBased on NO_x modeling results

Since the impacts are above the PSD modeling significance levels but below the NAAQS/MAAQs and Class II increment, the predicted modeling impacts for SO₂, NO₂, and PM₁₀ from the proposed Project, by itself, are considered moderate. Furthermore, the facility requires a cumulative impact analysis. Predicted impacts from CO are below the PSD modeling significance levels; therefore, these impacts are considered low.

Identification of Class I Impacts

The CALPUFF model was used for the visibility, Class I increment, and acid deposition analyses. Input variables for CALPUFF, CALMET (met preprocessor), and CALPOST (post-process) are detailed in the modeling protocol that was submitted with the air quality permit application (Bull Mountain Development Company LLC., 2002b).

A Class I AQRV analysis includes potential impacts from the Project on visibility, soils, plants, animals, and potential acid deposition on nearby Class I areas. ISC3 modeling results were used in the screening analysis for impacts to soils, plants, and animals. The screening analysis indicates that the maximum ambient impacts near the facility should be used as screening values for the Class I areas.

Class I Visibility Impacts

The CAA includes provisions for the protection of visibility in certain Class I areas. Visibility protection requirements are included in EPA's PSD program and Montana's air quality permitting program. The rules require that the Proponent demonstrate that the air contaminant emissions from the major source or modification would not cause or contribute to adverse impact on visibility within any federal mandatory Class I area. Class I areas can also be classified as non-federal Class I areas. Non-federal Class I areas are not subject to the same regulations as the

federal mandatory Class I areas. These types of areas typically include Indian Reservations. It is important to note, the Montana air quality regulations do not require a cumulative visibility analysis only a visibility analysis from the Project (A.R.M. 17.8.11, 1996). However, the rules adopted pursuant to the Montana Environmental Policy Act (MEPA) state that cumulative impacts must be addressed in an Environmental Impact Statement (EIS)(A.R.M. 17.4.617).

The nearest mandatory Class I areas to the Project are the UL Bend Wilderness Area, located 130 km (81 miles) northeast of the site; Yellowstone National Park (YNP), located 180 km southwest of the site; and North Absaroka Wilderness (NAW), located 180 km (112 miles) southwest of the site in Wyoming near the northeast boundary of YNP. The closest non-federal Class I area is the Northern Cheyenne Reservation (NCR), located 130 (81 miles) km southwest of the site.

The FLAG document suggests that if the daily change in extinction is less than 5% daily then the FLMs are likely not to claim adverse impacts on the Class I area from the facility. If the daily change in extinction is between 5% and 10%, then the FLM is likely to request a cumulative analysis for visibility impairment. Finally, if the daily change in extinction is above 10% from the facility, then the FLM is likely to claim adverse effects on the Class I area and is likely to object to issuance of a final air quality permit unless the facility takes mitigation measures and, as a result, shows no adverse visibility impairment on the Class I area. (USFS, NPS, and USFWS, 2000).

CALPUFF modeling was used for the visibility analysis to assess the reduction in visual range relative to the natural background for these nearby Class I areas. The CALPUFF model used corrected 1990 MM4 met data (as provided by the National Park Service). The CALPUFF modeling results, based on the assumption of maximum emissions (5% overpressure condition) from the Project boilers, are summarized in Table 4-10.

Table 4-10 Visibility Analysis Results for the Roundup Power Project

Class I Area	Days Above 10%	Days Above 5%	Maximum Change (%)
Mandatory Federal Class I Areas			
Yellowstone National Park	1	9	13.0
UL Bend Wilderness	0	4	7.9
North Absaroka Wilderness	1	6	11.1
Non-federal Class I Areas			
Northern Cheyenne Reservation	15	38	41.01

Source: Letter to Dan Walsh, DEQ from Bull Mountain Development Co., L.L.C, 2001; Bull Mountain Development Company LLC., 2002a and Letter to Dan Walsh, DEQ from Diane Lorenzen, Nov. 7, 2002.

Since impacts are above 5% in all federal mandatory Class I areas, a cumulative visibility analysis was completed (see Section 4.14 and Appendix B). Model-predicted impacts are above 10% in YNP and the NAW; therefore, the predicted impacts would be considered high at these

two Class 1 areas. The model-predicted impacts are above 5% for the UL Bend; therefore, the predicted impacts would be considered moderate at UL Bend.

Visibility modeling results for the non-federal Class I area (e.g., NCR) are also included. Representative background light extinction data are not available for the NCR; therefore, it is not possible to calculate realistic estimates of the potential change from existing conditions. Since the impacts on the NCR are above 10%, the predicted impacts would be considered high at the NCR.

Class I Increment Impacts

The impacts from the Project to the Class I increment were analyzed to see if the facility was significant to the aforementioned Class I areas. The recognized significance level for Class I increment is 4% of the Class I increment per averaging period and pollutant. If the consumed Class I increment is above 4%, then a cumulative analysis is recommended by the FLM. Table 4-11 summarizes the Class I increment.

Table 4-11 Class I Increment Impacts

Pollutant	Average Period	YNP Impacts (µg/m³)	UL Bend Impacts (µg/m³)	NAW Impacts (µg/m³)	NCR Impacts (µg/m³)	PSD Class I Increment (µg/m³)	PSD Class I Sig. Level (µg/m³)
NO ₂	Annual	0.0004	0.0002	0.0004	0.017	2.5	0.1
	Annual	0.006	0.011	0.007	0.057	2	0.8
SO ₂	24-hour ^a	0.30	0.29	0.17	0.66	5	0.2
	3-hour ^a	0.86	0.95	0.87	1.65	25	1.0
PM ₁₀	Annual	0.001	0.002	0.002	0.009	4	0.16
	24-hour ^a	0.05	0.05	0.03 ^a	0.09	8	0.32

Source: Memo to Dan Walsh, DEQ from Diane Lorenzen, P.E., 2002

^aBased on High Second High Impact.

Since predicted impacts from the proposed Project, by itself, for NO₂ and PM₁₀ are below the PSD Class I significance levels, the impacts are considered low. The predicted impacts for SO₂ are considered moderate because the impacts are above the PSD Class I significance levels and below the PSD Class I increments.

Class I Acid Deposition Impacts

The CALPUFF modeling produced estimates of Class I acid deposition impacts. Deposition values are reported for total nitrogen (N) and total sulfur (S) in units of kilogram per hectare per year (kg/ha/yr). The total N deposition values are the sum of the dry NO_x, dry NO₃, dry HNO₃, wet NO₃, and wet HNO₃ deposition. The total S deposition is the sum of dry SO₂, wet SO₂, dry SO₄, and wet SO₄ deposition. Peak modeled deposition rates for the Class I area receptors are presented in Table 4-12. The recommended DAT for acid deposition for either S or N deposition is 0.005 kg/ha/yr (NPS and USFWS, 2002).

Table 4-12 CALPUFF Modeling Deposition Results

Class I Receptor Location	Peak Impact Total N Deposition (kg/ha/yr)	Peak Impact Total S Deposition (kg/ha/yr)
Yellowstone National Park	4.17E-04	3.31E-03
UL Bend Wilderness Area	1.46E-03	1.02E-02
North Absaroka Wilderness Area	4.49E-04	3.64E-03

Source: Letter to Dan Walsh, DEQ from Steven T. Wade, 2002

Only the S deposition at the UL Bend Wilderness area is above the DAT of 0.005 kg/ha/yr. Therefore, these predicted impacts would be considered moderate since they do not exceed 0.125 kg/ha/yr. At this level, the FLM may request a cumulative analysis for the Class I area. However, the DAT is only a screening value, which is 4% of the level of concern for adverse impacts to the Class I area (NPS and USFWS, 2002). Since no other major SO₂ emitting sources are within 200 km of the UL Bend Wilderness and the S deposition is only 8.2% of the level of concern, a cumulative S depositional analysis is considered not necessary. The remaining predicted acid deposition impacts are below 0.005 kg/ha/yr; therefore, the predicted impacts would be considered low.

Class II Acid Deposition Impacts

Deposition of sulfur and nitrogen in Class II areas is also of concern due to the potential effects of acid deposition on surface waters. Deposition values were obtained from the CALPUFF modeling for several receptors in the Class II areas surrounding Yellowstone National Park. Table 4-13 lists the deposition values for individual Class II area receptors.

Table 4-13 Nitrogen and Sulfur Deposition at Critical Class II Receptors Near Yellowstone National Park

Receptor Description	Total N Deposition (kg/ha/yr)	Total S Deposition (kg/ha/yr)
Sunset Peak	4.04E-04	3.33E-03
Meridian Peak	3.90E-04	3.25E-03
Wolverine Peak	4.08E-04	3.35E-03
Mount Abundance	4.26E-04	3.44E-03
Cooke City Ranger Station	3.75E-04	3.16E-03
Granite Peak	6.10E-04	3.56E-03
Mystic Lake	7.70E-04	3.42E-03
Monument Peak	5.32E-04	3.85E-03
Twin Outlet Lake	5.61E-04	4.34E-03
Stepping Stone Lake	5.15E-04	4.04E-03

Source: Bull Mountain Development Company, 2002a.

None of the predicted total S or N deposition values at any of the Class II areas are above 0.005 kg/ha/yr; therefore, the predicted impacts would be considered low. Also, the Gallatin National Forest Service in a letter to DEQ dated June 6, 2002, stated that an analysis was conducted based on the deposition results in Table 4-13. The Forest Service concluded that the Project's impacts from deposition would be considered low on these Class II areas (Story, 2002)

Class I Screening Impacts on Plants, Soils, and Animals

An EPA screening document was used to determine the impact of increases in SO₂, CO, NO_x, and VOC from the Project (EPA, 1980). The screening document provides information on the levels of air pollution that result in damage to plants, soils, or animals or an increase in sensitivity to the air pollutants. For the purpose of this analysis, all of the VOC emissions are assumed to be converted to ozone. The results in Table 4-14 show that the predicted impacts from the proposed Project are below the sensitive species concentrations; therefore, the predicted impacts would be considered low.

Table 4-14 Existing Ambient Air Quality Concentrations Values

Pollutant	Averaging Time	Sensitive Species^a (µg/m³)	Predicted Impact (µg/m³)
Nitrogen Dioxide	4 hour	3,760	153
	8 hour	3,760	86.3
	1 month	564	74.6 ^b
	1 year	94	1.02
	1 hour	392	19.8
Ozone (as VOC)	4 hour	239	8.91
	8 hour	67.9	5.03
	1 hour	1,725	106
Sulfur Dioxide	3 hour	1,125	52.8
	1 year	18	2.36
Lead	3 months	1.5	0.0025
Carbon Monoxide	1 week	1,800,000	23.7 ^b

Source: Bull Mountain Development Company, LLC., 2002b

^aSensitive species are listed in Table 3.1 of the screening document

^bBased on 24-hour modeling impact

Screening Impacts From Heavy Metals

The EPA screening document was also used to examine heavy metal contamination in the soil that may affect soils, plants, and animals (EPA, 1980). Ambient impacts obtained from the ISC3 model were calculated based on annual modeling results. Modeled concentrations of metals were converted to a deposited concentration then compared to screening values by the following equation (Bull Mountain Development Company LLC., 2002b).

$$DC = \text{Deposition Concentration (ppm)} = 21.5 * (N/d)X$$

Where:

N = Lifetime of facility in years = 40 years

d = depth of soil for deposited material = 3 cm

X = maximum annual average concentration

The results of the calculations are compared with screening levels from the screening document and presented in Table 4-15.

Table 4-15 Screening Analysis for Heavy Metal Deposition in Soils

Metal	Maximum Annual Average Concentration ($\mu\text{g}/\text{m}^3$)	Deposited Concentration (ppm)	Screening Values (ppm)		
			Soil	Plant	Animal
Arsenic	3.30×10^{-5}	9.46×10^{-3}	3	1.8	21
Cadmium	1.45×10^{-5}	4.16×10^{-3}	2.5	0.28	1.4
Chromium	6.12×10^{-5}	1.75×10^{-2}	8.4	50	---
Cobalt	2.70×10^{-5}	7.74×10^{-3}	1,000	280	180
Fluoride	6.62×10^{-3}	1.90	400	10,300	3,300
Manganese	2.33×10^{-4}	6.68×10^{-2}	2.5	6,100	7,600
Mercury	6.55×10^{-5}	1.88×10^{-2}	455	--	--
Nickel	7.55×10^{-5}	2.16×10^{-2}	500	1,300	22,000
Lead	1.14×10^{-4}	3.27×10^{-2}	1,000	280	180
Selenium	6.98×10^{-4}	0.20	500	1,300	22,000

Source: Bull Mountain Development Company LLC., 2002b

Since the deposited concentrations are below the screening values, it is presumed that heavy metal deposition during the proposed life of the Project would have low impacts to soils, plants, and animals.

Greenhouse Gas Estimates

This section provides information on emissions that could increase the concentration of greenhouse gases that contribute to the “greenhouse effect” in the atmosphere. The greenhouse effect is described in the “Introduction to Estimating Greenhouse Gas Emissions”(EPA, 1999) as:

The Earth naturally absorbs and reflects incoming solar radiation and emits longer wavelength terrestrial (thermal) radiation back into space. On average, the absorbed solar radiation is balanced by the outgoing terrestrial radiation emitted to space. A portion of this terrestrial radiation, though, is itself absorbed by gases in the atmosphere. The energy from this absorbed terrestrial radiation warms the Earth’s surface and atmosphere, creating what is known as the “natural greenhouse effect.” Without the natural heat-

trapping properties of these atmospheric gases, the average surface temperature of the Earth would be about 34 degrees Celsius (93 degrees Fahrenheit) lower.

The greenhouse effect is primarily a function of the concentration of water vapor, carbon dioxide, and other trace gases in the atmosphere that absorb the terrestrial radiation leaving the surface of the Earth. Changes in the atmospheric concentrations of these greenhouse gases can alter the balance of energy transfers between the atmosphere, space, land, and the oceans. A gauge of these changes is called radiative forcing, which is a simple measure of changes in the energy available to the Earth-atmosphere system. Holding everything else constant, increases in greenhouse gas concentrations in the atmosphere would produce positive radiative forcing.

The United Nations Environment Programme has established the Intergovernmental Panel on Climate Change (IPCC) to “assess the scientific, technical and socio-economic information relevant for the understanding of the risk of human-induced climate change” (IPCC 2002). The IPCC has developed a global warming potential (GWP) factor for most of the direct greenhouse gases. The GWP is defined as the cumulative radiative forcing—both direct and indirect—over a 100-year period.

Direct effects occur when the gas itself is a greenhouse gas. Indirect radiative forcing occurs when chemical transformations involving the original gas produce a gas or gases that are greenhouse gases, or when a gas influences the atmospheric lifetimes of other gases. The forcing is measured relative to a reference gas, carbon dioxide (CO₂), and is expressed in terms of metric tons of carbon equivalent. GWP factors have not been established for the indirect greenhouse gases because there is no agreed-upon method to estimate the contributions of the gases to radiative forcing.

A quantitative emissions inventory of the greenhouse gas emissions from the Project is provided in this section, based on EPA guidance and calculation methodologies. Direct greenhouse gases, including CO₂, methane (CH₄), and nitrous oxide (N₂O), are formed during the combustion of fossil fuels. The indirect greenhouse gases that are emitted from the combustion of fossil fuels include NO_x, CO, and non-methane volatile organic compounds (NMVOCs). Other direct greenhouse gases, which are not products of coal combustion, include chlorofluorocarbons (CFCs), hydrochlorofluorocarbons (HCFCs), hydrofluorocarbons (HFCs), perfluorocarbons (PFCs), and sulfur hexafluoride (SF₆).

The primary greenhouse gas emitted from coal burning is CO₂. Most of the carbon contained in fossil fuels is emitted as CO₂ during the fuel combustion process. The remainder is emitted as CO, CH₄, or NMVOCs, all of which oxidize to CO₂ in the atmosphere within a time range of a few days to about 11 years. Table 4-16 lists the estimated greenhouse gas emissions from the Project in several different units of measure.

Table 4-16 Estimated Roundup Power Project Greenhouse Gas Emissions

Gas	Emissions (ton/yr)	Emissions (lb/MWh)	Emissions (metric tons/yr)	Emissions (kg/MWh)
CO ₂	8,199,803	2,496	7,454,366	2,269
CH ₄	65.96	0.020	60	0.018

Gas	Emissions (ton/yr)	Emissions (lb/MWh)	Emissions (metric tons/yr)	Emissions (kg/MWh)
N ₂ O	49.56	0.015	45	0.014
CO	4,917	1.50	4,470	1.36
NO _x	2,329	0.709	2,117	0.645
NM VOC	99.45	0.030	90	0.028

Source: Bull Mountain Development Company, LLC., 2002a.

Table 4-17 summarizes the Project greenhouse gas emissions relative to the US (year 2000) trends for greenhouse gasses. The table also lists the total greenhouse gasses from electric generation and transportation in US. The greenhouse gas emissions from the Project are calculated to be approximately 0.12 % of the total greenhouse gas emissions in the US.

Table 4-17 Estimated Greenhouse Gases in US and from the Project

	Emissions (million tpy)	% of Total US Greenhouse Gases
US Trends for all Greenhouse Gases	7001	--
Electric Generation for all Greenhouse Gases	2376	33.94%
Transportation for all Greenhouse gases	1877	26.81%
Roundup Power Project	8.2	0.12%

Source: EPA Specific Emission Inventory, 2002.

The data in Table 4-16 and Table 4-17 provide information needed to compare the greenhouse gas emissions from the Project to nationwide greenhouse gas emissions. No basis exists for determining the severity of greenhouse gases impacts on global warming; therefore, an impact level cannot be assigned.

161kV Transmission System

No impacts to existing air quality are expected from the 161kV Transmission System except during construction activities. Fugitive dust emissions would be expected during construction but would cease after construction has ended. As such, adverse effects to air quality are expected to be low from the 161kV Transmission System.

4.2.3 Action Alternatives

Landfill Alternative

No significant increase of fugitive emission impacts is expected from an expansion of the landfill for waste disposal. Fugitive emissions may slightly increase and/or change location for this alternative. New fugitive emissions would also occur during the construction of the landfill and

cease after construction has ended. Therefore, adverse effects to the airshed from this alternative are expected to be similar to those described for the Proposed Action.

230kV Transmission System

No impacts to existing air quality are expected from the alternative 230kV Transmission System except during the construction. Fugitive dust emissions would be expected during construction but would cease after construction has ended. Therefore, low adverse effects to the airshed are expected from a 230kV Transmission System.

Summary of Impacts

Table 4-18 summarizes the potential impacts to air resources from the proposed actions and the alternative actions. The proposed activity, potential impact, and impact severity are outlined in the table.

Table 4-18 Summary of Potential Impacts to Air Resources

Proposed Activity	Potential Impact to Air Resources	Impact Severity
Proposed Actions		
Generation Plant	NAAQS/MAAQS	Moderate for PM ₁₀ , NO ₂ , SO ₂ . Low for CO.
	PSD Class II Increment	Moderate for PM ₁₀ , NO ₂ , SO ₂ . Low for CO.
	PSD Class I Increment	Moderate for SO ₂ at Yellowstone National Park, North Absaroka Wilderness, UL Bend Wilderness, and Northern Cheyenne Reservation. Low for NO ₂ and PM ₁₀ at Yellowstone National Park, North Absaroka Wilderness, UL Bend Wilderness, and Northern Cheyenne Reservation.
	Class I Visibility	High at Yellowstone National Park, North Absaroka Wilderness, and Northern Cheyenne Reservation. Moderate at UL Bend Wilderness.
	PSD Class I Acid Deposition	Moderate at UL Bend Wilderness. Low at Yellowstone National Park and North Absaroka Wilderness.
	PSD Class II Acid Deposition	Low at specific Class II areas surrounding Yellowstone National Park.
	PSD Class I Impacts from Gaseous Pollutants to Plants, Soils, and Animals	Low compared to screening levels.

Proposed Activity	Potential Impact to Air Resources	Impact Severity
	PSD Class I Impacts from Heavy Metals to Plants, Soils, and Animals	Low compared to screening levels.
	Greenhouse Gas Emissions	No basis exists to measure severity on global warming.
160 kV Transmission System	Fugitive Emissions – Emissions of PM ₁₀ from Construction	No impacts to existing air quality are expected from the 160kV Transmission System except during construction.
Alternative Actions		
Landfill Alternative	Fugitive Emissions – Emissions of PM ₁₀ from Construction	No significant increase of fugitive emission impacts is expected from an expansion of the landfill for waste disposal.
230kV Transmission System	Fugitive Emissions – Emissions of PM ₁₀ from Construction	No impacts to existing air quality are expected from the 230kV Transmission System except during construction.

4.2.4 Mitigation Measures

Mitigation measures, actions that could be taken to reduce impacts but that cannot be required through DEQ's statutory authority, can be enforced if the Project proponent requests that they be incorporated into a permit. Suggested mitigation measures for the Project and alternatives are provided in Chapter 2, Section 2.2.5 in the Air Quality subsection. Measures include dust control, coal cleaning and handling techniques, and emission control technologies.

Coal cleaning and/or coal preparation (e.g., drying) technologies are a potential means of reducing virtually all criteria pollutant emissions and many HAP emissions by improving heat rate and boiler efficiency. Those technologies can have both a direct and indirect effect on emissions, with the magnitude of the effect dependent upon the coal characteristics and the use of other pollutant controls.

Coal cleaning can directly affect emissions by removing impurities in the coal, which ultimately leave the process as air pollutants. For example, coal cleaning can remove pyretic sulfur from the fuel and, as a result, reduce sulfur dioxide emissions from the boiler, expressed as pounds per million Btu of heat input. Coal cleaning may also reduce the amount of mercury in the coal and, therefore, the amount of mercury emitted from the boiler.

Coal cleaning can indirectly affect the emission rates for virtually all criteria pollutants by removing impurities (coal cleaning) and by increasing the heating value of the coal (coal cleaning and drying). For example, removing precursors to ash can improve heat transfer efficiency in the furnace section of the boiler by reducing ash and improving ash chemistry relative to slagging. Removing moisture from the coal may serve to avoid the need to provide heat for vaporization and may reduce the amount of gas (by reducing water vapor) that must be moved by the fan. In both cases, it may mean less heat input would be needed to obtain a given amount of energy out. Traditional coal cleaning processes require available water and

handling/disposal of water used in the cleaning process. Because of these water issues, coal cleaning was rejected as a potential emissions control technology during the Project BACT analysis.

A dry coal cleaning process under development in North Dakota may hold promise for reducing emissions from coal-fired generation plants. Current development of the technology is being done on lignite-fired generation plants in North Dakota, where it holds promise for reducing both criteria pollutants and HAPs. A feasibility and cost effectiveness study would need to be conducted to determine if this developing technology has application to the Project.

The proponent has recommended 80% NO_x control efficiency for the proposed SCR unit. Literature reports that SCR units can achieve up to 90% NO_x control. The NO_x BACT discussed and eliminated a higher control efficiency of 90% for an SCR unit. Nevertheless, a higher NO_x control efficiency from the SCR unit (between 80% and 90%) could be achievable and could mitigate some impacts from NO_x emissions. A cost optimization study to balance the reductions in NO_x emissions with the costs of mandating a higher NO_x control efficiency would better define the appropriate level of NO_x control.

Greenhouse gas reduction programs have been part of agreements between power plant developers and environmental protection organizations to settle appeals of air quality permits for new power projects in Montana. Carbon sequestration has been a proposed mitigation measure for reducing impacts from greenhouse gases emitted from the power projects. One agreement settling an appeal of a natural gas fired power generating facility specified carbon sequestration through the planting of 100,000 trees. Other proposed mitigation strategies in these proposals have included funding and implementing energy conservation programs (e.g., purchase of energy efficient light bulbs, preparation of energy education programs and conservation incentives, etc.). In a natural gas-fired plant permit appeal, the developer agreed to purchase 50, 000 efficient light bulbs for distribution to electricity consumers.

4.2.5 No-Action Alternative

Under the No-Action alternative, the Project would not be built; therefore, no impacts to air quality would occur as a result of the Project.

4.3 Water Resources

This section describes the types of impacts that would potentially occur to surface and groundwater resources from construction and operation of the proposed Project and its alternatives as described in Chapter 2. Mitigation measures and Project design used to reduce or eliminate potential impacts to surface water and groundwater resources are also discussed.

4.3.1 Methods

In order to assess the impacts associated with construction and operation of the Project (Generation Plant and Transmission System), the proposed construction, operation and maintenance activities were reviewed. Information was obtained from the Supplemental EIS Support Document (Bull Mountain Development Co., LLC, 2002a) for background information on the water resources analysis. The Bull Mountains Mine FEIS (Montana Dept. of State Lands,

1992) and the Railroad Spur Checklist EA (DNRC, Trust Land Management Division, FF) were also used as references for this assessment. A professional determination, based on the topography and locations of sensitive features, was then made of how these activities may impact water resources.

Impact Levels

Impacts on water resources would be classified in this document as high if the action being considered would result in one or more of the following:

- A substantial degradation of surface or groundwater quality to the extent that beneficial uses are affected or impacts would result in either the short or long-term violation of state or federal agency water quality standards or objectives
- Substantial erosion, scour, or siltation that would affect public water supplies or aquatic life
- An alteration of existing drainages in a manner that could substantially negatively affect listed and/or sensitive species or associated habitats
- The possibility of oil spills from the oil storage tank or plant equipment reaching surface or groundwater where no spill containment or protective measures are used
- Construction would substantially alter recharge to an aquifer resulting in a decrease in local well production rates
- Plant supply well withdrawals would impact other users on the Madison Aquifer

Impacts on water resources would be classified in this document as moderate if the action being considered would result in one or more of the following:

- New roads would be constructed across a stream or where existing stream crossings are inadequate and would require re-building
- Impacts would be primarily short-term, with an increase in normal erosion rates for a few years following soil disturbance until erosion and drainage controls become effective
- There would be little possibility of oil spills or other pollutants affecting surface or groundwater, and facilities have some minor spill protective measures
- Surface or groundwater quality degrades in violation of state or federal standards, but can be partially mitigated to lessen impacts
- Construction alters recharge to an aquifer resulting in a short term change in groundwater levels

Impacts on water resources would be classified in this document as low if the action being considered would result in one or more of the following:

- Impacts to water quality could be easily mitigated to state or federal standards with common mitigation measures and Project design
- There would be little possibility of oil or other pollutants affecting surface or groundwater, and facilities have good spill containment protective measures

- Structures would be away from water bodies and little or no sediments would reach the water
- Extraction rates in production wells caused only localized drawdown in the screened aquifer

No impact would occur where water quality or groundwater levels would remain unchanged.

4.3.2 Proposed Action

There are several general adverse impacts to water resources that could potentially be caused by the Project:

- Runoff can increase sedimentation and water turbidity
- Capture of runoff can decrease downstream water availability
- Contamination of surface water or groundwater can occur due to spills, runoff, or leachate from plant operation or landfills
- Road improvements and vehicular traffic at stream crossings can increase turbidity and alter stream channels
- Clearing streamside vegetation can increase a stream's exposure to sunlight, possibly raising water temperature
- The impervious area occupied by the plant and waste landfills can eliminate recharge from natural sources
- Water produced from wells drilled for the plant could alter or lower water levels in local aquifers if the new plant production wells were not cased through the shallow aquifer

Generation Plant

Direct impacts from the Project's Generation Plant include disturbance of approximately 208 acres of watershed that would be removed from the Rehder Creek and Halfbreed Creek drainage basins. This acreage amounts to a very small percentage (less than ½ of 1%) of the total drainage areas for Rehder and Halfbreed Creeks. All precipitation that falls within the boundaries of the plant facilities, and would normally run off into nearby drainages, would be contained in a "zero discharge" sediment control system. This system would contain all waters used in the Generation Plant operations, along with storm water diverted into sediment control ponds. Water from this system would be recycled within the Generation Plant.

The storm water flow across undisturbed areas of the site would be maintained with storm water discharging to natural drainage courses. The storm water drainage system for the Generation Plant Study Area would be designed to discharge the peak 10-year, 24-hour runoff without backup of water in the sewer and ditch systems, and the 50-year, 24-hour runoff without flooding roads or equipment areas.

Storm water runoff from the Generation Plant Study Area would be collected in three storm water detention ponds. These ponds would detain the runoff to settle suspended solids and

reduce downstream flooding. Each pond would be designed to contain storm water runoff from a 25-year, 24-hour storm event

There is a leachate collection pond designed to store storm water from waste disposal cells 1 and 2. The collection pond would be designed for an appropriate storm event and is expected to be less than 10 acre-feet when designed.

Since there are no surface water bodies or streams in the Generation Plant Study Area, no direct or indirect impacts are anticipated.

No impact would occur to groundwater if the “zero discharge” system is properly implemented and does not experience any unplanned releases. The Generation Plant Study Area is located on rocks of the Fort Union Formation, which is composed of sandstone, siltstone, claystone, and coal beds. No coal mining would occur in this area. The downward movement of fluids originating from releases or storm water overflow into these sediments would be retarded by the low hydraulic conductivity and permeability of the shale and silt interbeds. If a regulated material or petroleum hydrocarbon release occurs and impacts the subsurface, standard release and investigation site characterization and remediation measures would minimize impacts to groundwater. The potential for releases would be decreased by the routine observation of containment berms, sumps and floor areas as required by MPDES permits, landfill management operation and maintenance guidelines, and the proponent’s Best Management Practices to be defined as part of the water permitting process.

Two aquifers may be impacted from construction of the Generation Plant. Local domestic wells produce water from shallow perched aquifers in the Fort Union Formation. Production wells for the plant would be completed in the deeper Madison Aquifer. The wells associated with this Project would extract water from the Madison Aquifer, and are not likely to influence local shallow aquifers.

The supply wells produce a minimum of 1,050 gallons per minute (gpm) required for the Generation Plant. These wells would be drilled approximately 8,500 feet below ground surface (bgs) into the Madison Aquifer. The wells would penetrate approximately 600 feet into the Madison Aquifer.

Twenty-six separate geologic formations occur between the surface aquifers and the deeper Madison Aquifer. These formations contain thousands of feet of impermeable geologic strata in the form of clays and shales, which can restrict vertical movement of water between aquifers. The potential for impact on the shallow aquifer from withdrawals originating in the Madison Aquifer is low.

The Madison Aquifer has hydrostatic pressure that would cause water to rise upward in wells installed by the Project. The elevated hydrostatic pressures in the Madison Aquifer would likely result in water levels rising in the well casings to within 300 feet of the surface. These deep wells would require proper installation in accordance with A.R.M. 36.21.660 of the Montana Department of Natural Resources and Conservation (DNRC), Water Resource Division to minimize the potential of commingling of water from different aquifers.

Recharge in the Madison Aquifer comes from mountain ranges tens to hundreds of miles distant. There are no local users of the Madison Aquifer near the Generation Plant Study Area. The

proposed production rate is considered slight in comparison to the total water resource available in the Madison Aquifer.

Wells currently being used by local homeowners and ranchers produce water from shallow aquifers in the Fort Union Formation. The shallow aquifers gain water mainly through recharge from precipitation and leakage from underlying near surface aquifers. Elimination of the recharge area beneath the Generation Plant footprint may influence local shallow aquifers. If the recharge area of a particular aquifer is to a great degree altered by the Generation Plant, the aquifer may experience a slight decrease in productivity.

On-site waste disposal by landfill is proposed for the initial ten-year Generation Plant operation. Subsequent to the ten-year period, solid waste would be transported and stored in the Mine for disposal. The impacts of storing solid wastes in the Mine are unknown at this time and would require additional investigation prior to beginning that phase of the Project. Unknown factors associated with Mine storage of the solid waste include:

- Conveyance type and route to the Mine site
- Estimated size of the proposed underground landfill
- Relationship of the landfill area to groundwater levels
- Hydrogeologic characteristics of the area of the Mine to receive the waste
- Relationship of the waste storage site to groundwater recharge and discharge pathways
- Leaching characteristics of the waste

Potential impacts for underground storage of solid waste cannot be quantified at this time, but could include elevated concentrations of TDS and metals, and impacts to spring and well production due to replacement of the aquifer material (coal) with the low permeability ash waste. Additional environmental review may be necessary when plans are prepared and reviewed before Mine storage construction begins.

161kV Transmission System

Direct impacts would be caused by access road construction or improvements, maintenance activities, right-of-way clearing, and site preparation for structures and work areas. Several ephemeral drainages may be crossed. Existing roads and fords would be used wherever feasible, however, new culverts or fords may be required in some locations. No perennial streams would be crossed.

A portion of the proposed Transmission System crosses the Hay Basin lakebed east of State Highway 3 approximately 12 miles east of Broadview. This area is underlain by lakebed deposits consisting of silt and clay. Because these soils are poorly drained, runoff from higher lying land may cause the area to pond for several days or weeks following heavy rains or snow melt. Groundwater is likely to be less than three feet below ground surface (bgs) during portions of the year. Construction impacts would be minimized by avoiding this area during the wet period, or construction of an all-weather access road. Construction and maintenance impacts to this area could be eliminated by avoiding this area and rerouting the alignment.

At this time, exact crossing locations are not known. Until final designs are completed, the amount of ground disturbance and number of crossings is not known. Following construction, implementation of mitigation measures listed below including erosion control and revegetation would reduce impacts to a minimum and would not cause degradation of water quality below state or federal standards.

4.3.3 Action Alternatives

Landfill Alternative

Potential impacts from an alternative that includes expanding the on-site landfill would be similar to those described for the Proposed Action. All plant operations involving products that could contaminate surface or groundwater would have containment systems as described above. As such, impacts to surface water bodies or groundwater would be low.

230kV Transmission System

Impacts associated with an alternative that includes construction and operation of a 230kV system would be substantially the same as the impacts described for the Proposed Action utilizing a 161kV system. Road construction or improvement, and ground disturbance resulting from site preparation and right-of-way clearing would be identical. Following construction, implementation of mitigation measures listed below including erosion control and revegetation would reduce impacts to a minimum and would not cause degradation of water quality below state or federal standards.

4.3.4 Mitigation Measures

Since no perennial streams would be impacted at the Generation Plant Study Area or the Transmission System Study Area, the Montana Natural Streambed and Land Preservation Act (310) permit would not be required. Prior to construction, a jurisdictional determination would be requested from the U.S. Army Corps of Engineers to confirm that no jurisdictional waters occur in the Generation Plant Study Area or the Transmission System Study Area. If this were the case, no 404 permit would be required. Storm water permits associated with construction activities and industrial operations would be required (Refer to Table 1-1 in Chapter 1).

The following measures, associated with the Proposed Action and alternatives, would be enforceable as part of the DEQ water permitting processes (identified in Table 1-1, Chapter 1):

- Process wastewater from construction and operations would not be released into surface water or soil for migration to shallow groundwater
- Herbicides used for weed control would be applied according to the label instructions and by qualified personnel.
- Transmission system structures would be engineered and located to span streams and drainages.
- To minimize erosion and sedimentation transport in identified sensitive areas, temporary control measures (e.g. silt fences, straw bale fences, terracing, water bars, matting,

settling ponds, or other erosion control techniques) may be installed prior to and during construction.

- Water supply wells would be completed in accordance to DNRC regulations in a manner to prevent commingling of shallow and deep aquifer waters.

The regulatory agency does not have the authority to create mitigation measures that they can enforce, without the direct consent of the Project proponent. Mitigation measures proposed for water resources is listed in Chapter 2, Section 2.2.5 in the Water Resources subsection.

- Alternate water supplies may be necessary for a small number of wells that are proven to be directly influenced by reduction of recharge due to the plant construction.
- Installation of groundwater monitoring wells near the landfill area would serve to identify groundwater impacts from leachate releases. Groundwater monitoring wells should be installed prior to startup of landfill operation in order to establish baseline conditions. A minimum of three groundwater-monitoring wells would be required to characterize groundwater quality and flow direction beneath the landfill area.

Measures recommended for other resources would also further reduce or eliminate impacts to surface waters and groundwater.

4.3.5 No-Action Alternative

With the No-Action Alternative, there would not be any impacts to the surface water or groundwater resources of the area, beyond those that may be caused by the Mine and other existing actions.

4.4 Earth Resources

This section describes the types of impacts that would potentially occur to earth resources from construction, operation and maintenance of the Project, and alternatives as described in Chapter 2. Mitigation measures and Project design used to reduce or eliminate potential impacts to earth resources are also discussed.

4.4.1 Methods

In order to assess impacts to earth resources resulting from the Project or alternatives to the Project, the proposed construction, operation and maintenance activities were reviewed. Information was obtained from the Supplemental EIS Support Document (Bull Mountain Development Co., LLC, 2002a) for background information on earth resources. The Bull Mountains Mine FEIS (Montana Dept. of State Lands, 1992) and the Railroad Spur Checklist EA (DNRC, Trust Land Management Division, 2002) were also used as references for this assessment. of earth resources. A professional determination, based on the topography and locations of sensitive features, was made of how the Project and alternatives would potentially impact earth resources.

Impact Levels

Impacts on earth resources would be classified in this document as high if the action being considered would result in the following:

- Construction or clearing would be required on slopes that are prone to mass movement or have very high susceptibility to erosion
- Soil properties would be so unfavorable or difficult that standard mitigation measures such as revegetation, would be ineffective
- Long-term impacts associated with accelerated erosion, sedimentation, or disruption of unstable slopes would occur
- Destruction of unique geologic features or resources would be required
- A large volume release of fuel oil from an uncontained area that would flow overland and pool in drainages and swales

Impacts on earth resources would be classified in this document as moderate if the action being considered would result in the following:

- Impacts would be primarily short-term, with an increase in normal erosion rates for a few years following soil disturbance until erosion and drainage controls become effective
- Soil properties and site features are such that mitigation measures would be effective in controlling erosion and sedimentation to acceptable levels
- There would be little possibility of oil spills or other pollutants affecting surface soil, and facilities have some minor spill protective measures

Impacts on earth resources would be classified in this document as low if the action being considered would result in the following:

- There would be little possibility of oil or other pollutants impacting soil, and the facilities have adequate product spill prevention and containment measures
- Facility construction and clearing would be performed on soils with low to moderate erosion hazard, and the potential for mitigation would be good using standard erosion and runoff control practices

No impact would occur where earth materials would remain unchanged.

4.4.2 Proposed Action

There are several general impacts of concern relating to earth resources that potentially could result from the Project:

- Surface disturbance can increase the potential for wind and water erosion of exposed soils
- Soil contamination can occur due to spills, runoff, or leachate from plant operation

Generation Plant

Construction of the Generation Plant and associated facilities could slightly alter the surface topography of an existing plateau. In addition to the general site grading, there would be some additional topographic alteration to facilitate ponds, ditches, and the solid waste disposal and coal storage and handling areas. The estimated total surface disturbance is expected to be approximately 208 acres. This acreage would be irreversibly altered due to the development activities. The anticipated level of impacts to geologic features are low for construction of the Generation Plant and appurtenances.

Table 4-19 summarizes the soils impacts. An average of three inches of soil would be salvaged over the 208-acre Generation Plant site, for a total of about 83,570 cubic yards. This soil would be stored in four stockpiles located around the property. The soil would be available for future reclamation activities.

Table 4–19 Summary of Impacts on Geology and Soils from Construction and Operation of the Proposed Roundup Power Project

Impact	Impact Level	Rationale
Geologic features would be disturbed	Low	No unique or irreplaceable features present in the construction footprint
Increased soils erosion and offsite sedimentation	Low to moderate	Soil would be affected on about 208 acres. Soil would be salvaged to an average depth of three inches over this area. Wind and water erosion during construction would be minimized using standard practices stipulated in water and air quality permits. Some salvaged soil would be spread on sediment dam faces or other exposed subsoil areas following construction. Stockpiled soils and all soiled surfaces would be revegetated. Sediment ponds would be maintained to prevent downstream releases of sediment.
Soil contamination from leachate leakage or product spills	Low	Ponds, landfills, and fuel tank areas would be designed with protective barriers to prevent migration of liquid from source areas.
Long-term loss of soil productivity	Low	Soils productivity would be reduced over the short-term, but would be recovered over the long-term.

Construction activities, including soil salvage, would increase the potential for wind and water erosion and offsite sedimentation. Water and wind erosion on the site would be controlled using practices established for other environmental permits, particularly water quality and air quality permits. Sediment control dams would be constructed and maintained through the life of the Project to prevent offsite sedimentation. These impacts would be further mitigated by timely soil replacement and revegetation after construction of exposed surfaces such as the outfaces of sediment control dams, dikes, slopes, and other “idle” areas within the Generation Plant site.

The remaining salvaged soil would be stockpiled until needed to cover the solid waste disposal cells. These cells would be covered with a minimum of six inches of salvaged soil. Since the surface area of the cells would be approximately 25.6 acres, it would require a minimum of about 20,660 cubic yards of soil to cover these cells. It may be 10 years or longer before this soil is

needed. While the chemical and physical characteristics of the soils to be stripped are generally conducive for reclamation, it is reasonable to assume that some soil productivity would be lost during long-term storage due to potential changes in soils structure and texture, and reduced biological activity and nutrient content. Soils spread over the waste disposal cells would be revegetated. If necessary, mulching, fertilization and noxious weed control would be used to enhance revegetation success. Following replacement and revegetation, microorganisms should naturally recolonize these soils within a few years.

Sanitary water effluent would be discharged to the shallow subsurface in an engineered drainfield. Construction of the drainfield would cause permanent, localized saturation in the soil column beneath the drainfield, and add increased nitrogen, phosphate, TDS, and coliform loads to the current condition. Septic system design in accordance with DEQ regulations would result in low impact to the local soil conditions.

Impacts to shallow soil may occur from introduction of contaminants arising from wastewater pond or landfill leachate, releases from the 400,000-gallon fuel oil tank and rail car unloading area, sumps, other chemical usage areas, and uncontrolled surface spills. The landfill is exempt from Montana Solid Waste Management Act regulation, but would be constructed as described in Section 2.2.2 to minimize the potential for leachate release to the subsurface. Fuel oil tank area controls are required by DEQ MPDES and by US EPA– NPDES and Spill Prevention, Control and Countermeasure (SPCC) requirements. Implementation of these controls would minimize the potential for releases. Hazardous materials or petroleum hydrocarbon use, storage, and disposal in other areas should be conducted in accordance with manufacturers recommendations and US EPA Resource Conservation and Recovery Act (RCRA), Toxic Substance Control Act (TSCA) and other applicable state and federal regulations.

In summary, impacts to soil productivity in areas where soil was replaced after construction and operation of the Generation Plant would be low with implementation of standard mitigation measures. Productivity losses on unreclaimed portions of the Generation Plant site would be irretrievable. Impacts to soil from pond, landfill, or septic system leachate, petroleum hydrocarbon or hazardous materials releases would also be low with implementation of standard design controls and mitigation measures.

161kV Transmission System

Construction of the Transmission System would have a low impact to the geologic resources along the alignment. Minor displacement of earth materials can be expected with road construction and borings for pole placement. Small quantities of earth materials would be irretrievably lost due to construction and operation activities. These resources are not considered unique or irreplaceable in that there are abundant quantities of like material in the vicinity.

Direct impacts to soils would be caused by access road construction or improvements, maintenance activities, right-of-way clearing, and site preparation for structures and work areas. At this time, the actual line route and number of pole locations has not been identified. Until final design is completed, the total amount of ground disturbance is unknown. Following construction, implementation of mitigation measures listed below including erosion control and revegetation would reduce impacts to a minimum.

A portion of the proposed Transmission System alignment crosses the Hay Basin lakebed east of State Highway 3 approximately 12 miles east of Broadview. This area is underlain by lakebed deposits consisting of silt and clay. Soil developing on this material is highly erodible and subject to annual inundation during spring runoff and during above average precipitation years. Groundwater is likely to be less than three feet bgs during portions of the year. Construction impacts would be minimized by avoiding this area during wet period, or construction of an all-weather access road. Construction and maintenance impacts to this area could be eliminated by avoiding this area and rerouting the alignment.

4.4.3 Action Alternatives

Landfill Alternative

Potential impacts from an alternative to include expanding the on-site landfill would be similar to those described for the Proposed Action. Additional impacts would result from surface disturbance and soil needs for the landfill cap protective cover and vegetative layer. The landfill footprint would expand by a minimum of 70 acres, and require an additional 62,000 cubic yards of topsoil and 306,000 cubic yards of protective soil cover above the clay cap. The protective soil cover material could be used from the material excavated to construct the new landfill cells. Topsoil could be reclaimed from the soil stockpiles from initial plant construction, and stripping of the new landfill area. The increased soil disturbance and volumetric requirements for this alternative is considered to have a low impact to the environment.

Increasing the landfill area would also increase the risk of a leachate release through a failure in the liner. The potential for this would be minimized by adherence to the design specification and construction quality control. The potential impact of leachate contact to shallow soil from selection of this alternative is low.

Displacement of earth materials can be expected with the landfill alternative construction. Some earth materials would be irretrievably lost due to construction and operation activities. These resources are not considered unique or irreplaceable in that there are abundant quantities of like material in the vicinity.

230kV Transmission System

Impacts associated with an alternative to include the construction and operation of a 230kV Transmission System would be similar to those described for the Proposed Action (161kV Transmission System). However acres of impacts may be less due to the fewer number of poles likely required for the two, single-circuit 230kV lines as compared to the Proposed Action. Road construction or improvement, and ground disturbance resulting from site preparation and right-of-way clearing would be similar. Following construction, implementation of mitigation measures listed below including erosion control and revegetation would minimize impacts.

4.4.4 Mitigation Measures

The DEQ is responsible for enforcement of runoff control measures in the MPDES permit. The Mine landfill may be subject to regulation though the Montana Solid Waste Management Act if

provisions of the coal ash exemption are not met. A ruling in this regard has not been established as yet.

The following conditions would be placed in the MPDES permit and would be enforceable as part of the MPDES permit:

- Water from construction and operations would be routed around exposed soil surfaces
- Soil stockpiles would be stabilized by application of temporary cover or revegetation
- Transmission System structures would be engineered and located so as to span steep slopes and areas of highly erodible soils
- To minimize erosion and sedimentation transport in identified sensitive areas, temporary control measures (e.g. silt fences, straw bale fences, terracing, water bars, matting, settling ponds, or other erosion control techniques) would be installed prior to and during construction
- Spill containment and waste management controls would be implemented to minimize potential release of hazardous materials and petroleum hydrocarbon compounds.

The regulatory agency does not have the authority to create mitigation measures that they can enforce, without the direct consent of the Project proponent. Effective landfill management may substantially mitigate the potential adverse impact(s) from this Project. A Landfill Management Plan was identified as a recommended mitigation measure in Chapter 2, Section 2.2.5 in the Waste and Cleanup subsection. This Plan could avoid potential environmental impacts such as nuisance dust, erosion, storm water runoff, and inadvertent leachate release into soil and groundwater. The Plan would also establish guidelines for minimum construction and maintenance standards. A typical Landfill Management Plan would include the following subject areas:

- Specialized equipment and maintenance schedules
- Daily solid waste loads, design loads, and maximum loads
- Manpower training
- Standard operating procedures
- Dust control
- Leachate control
- Planning
- New cell construction
- Cell closure
- Storm water management
- Liner construction
- Groundwater monitoring (if applicable)
- Quality assurance
- Closure monitoring and maintenance
- Security
- Severe weather operations
- Safety and health requirements
- Record keeping

In addition, mitigation proposed for other resources listed in Section 2.2.5 would further reduce or eliminate impacts to soils and geologic features.

4.4.5 No-Action Alternative

With the No-Action Alternative, there would no impacts to the earth resources of the area, beyond those that may be caused by the Mine and other existing actions.

4.5 Botanical and Wetland Resources

This section describes the types of impacts that would potentially occur to botanical resources and wetlands from construction and operation of the Project, and alternatives as described in Chapter 2. Mitigation measures and Project design used to reduce or eliminate potential impacts to botanical resources and wetlands are also discussed.

4.5.1 Methods

In order to assess the impacts to botanical resources and wetlands from the Project, proposed construction, operation and maintenance activities were reviewed. Information was obtained from the Supplemental EIS Support Document (Bull Mountain Development Co., LLC, 2002a) for background information. The Bull Mountains Mine FEIS (Montana Dept. of State Lands, 1992) and the Railroad Spur Checklist EA (DNRC, Trust Land Management Division., 2002) were also used as references for the botanical and wetland assessment. A professional determination, based on the locations of vegetation habitat types, was made for how these activities may impact botanical resources and wetlands.

Impact Levels

Impacts to botanical resources and wetlands would be classified in this document as high if the action being considered would result in one or more of the following:

- There would be an irretrievable or irreversible loss of unique vegetation communities (vegetation communities defined by the Montana Natural Heritage Program as imperiled in the state).
- Federally listed, candidate, or state listed sensitive plant species were adversely affected.
- New noxious weed populations became established or existing populations of noxious weeds expanded.
- Surrounding vegetation was substantially affected (loss of ecosystem function or value) by emissions from the Generation Plant.
- A wetland area would be destroyed by permanently filling all or most of it, or by altering wetland hydrology.
- A wetland area would be destroyed that serves as habitat for a rare plant or animal species.

Impacts would be classified in this document as moderate if the action being considered would result in one or more of the following:

- Native plant communities would be permanently removed through removal of plant parts and/or altering the substrate upon which they exist.
- Native tree species in riparian areas would be removed or topped.
- A portion of a wetland area would be filled such that the majority of the wetland would still be able to function as a wetland (e.g., for a road crossing through a wetland adjacent to a creek).

Impacts would be classified in this document as low if the action being considered would result in one or more of the following:

- Native plant communities would be temporarily disturbed or altered such that recovery to pre-disturbance conditions would be likely.
- Vegetation would be permanently removed from a plant community dominated by non-native species.
- A wetland would be temporarily filled or wetland hydrology, soils, or vegetation would be altered. This would be followed by restoring the area to its former condition or enhancing the area.

No impact would occur where:

- Direct or indirect disturbance to native plant communities would be avoided.
- The habitats of rare plant species would be completely avoided.
- There would be no increase in the cover or distribution of noxious weeds.
- Direct impacts to wetlands would be avoided.
- Wetland hydrology, vegetation, or soils would not be affected by nearby activities.

4.5.2 Proposed Action

Generation Plant

Because there are no wetlands present in the Generation Plant Study Area, the Project would have no impact on wetland resources.

Potential impacts to vegetation are summarized in Table 4-20. Construction and operation and maintenance of the Generation Plant would result in the long-term loss of native and non-native vegetation on approximately 199 acres and the short-term loss of native vegetation on approximately 8 acres. Table 4-21 lists acreage affected in the Generation Plant Study Area by vegetation type. Burned ponderosa pine, grassland, go-back hay meadow, and ponderosa pine types would be the dominant vegetation types removed for the life of the Project. Temporary construction workspace would primarily affect burned ponderosa pine, grassland, and ponderosa pine vegetation types. Following the completion of construction, temporary workspace, downstream embankment faces, road and railroad cut and fill slopes, and areas within the plant

site not covered by facilities would be revegetated with grasses and forbs to reduce wind and water erosion, to provide competition with noxious weeds, and to enhance aesthetics.

Long-term loss of native vegetation would be a moderate impact, although these vegetation types are common in the area and acreage affected is small relative to the extent of the types in the Bull Mountains. Short-term loss of native vegetation would result in a low impact assuming revegetation efforts are successful. Revegetation of temporary workspace and other areas would reduce impacts, although diversity (number of species and presence of woody plants) would be reduced in revegetated areas.

According to the Project's application for an air quality permit (Bull Mountain Development Co., LLC, 2002b), increases over background levels of SO₂, NO_x, CO, VOC, and metals would result from the Project. Emissions from coal-fired generation plants are known to affect vegetation surrounding the emissions source, although changes in plant community structure, reduction in species diversity, and modifications to species composition have been documented only after severe and sustained exposure to pollutants (Grodzinski and Yorks, 1981). Ponderosa pine is sensitive to sulfur and trace elements, and studies around the Colstrip generation plants, southeast of the Generation Plant Study Area, have documented increases of sulfur and trace elements in ponderosa pine foliage, primarily within five miles downwind of the emissions source (Gordon et al. 1978, 1979; USGS 1979; Munshower et al. 1975; Munshower and Dupuit 1976). The studies showed, however, that pollutant output at Colstrip for the term of the studies was not sufficient to trigger changes in morphology of ponderosa pine needles.

No changes in plant community structure, species diversity, density, or primary productivity were proved after six years of monitoring in the Colstrip area (Taylor and Leininger 1980). Continued vegetation exposure over a longer term would be expected to result in increased pollutant levels, although studies covering 12 to 20 years at other coal-fired facilities have not documented significant changes in adjacent vegetation (Grodzinski and Yorks 1981).

Potential impacts to vegetation from coal-fired generation plant emissions in Montana have not been intensively evaluated since the Colstrip studies of the late 1970s. This is likely related to the lack of coal-fired generation plant development in the state, termination of funding for the Colstrip studies, and lack of significant vegetation impacts identified during the term of the Colstrip studies. Except for localized impacts related to seepage from the fly-ash ponds, impacts to vegetation peripheral to the Colstrip facilities are not visually apparent (T. Ring, DEQ, October 2002).

An environmental effects assessment for a proposed expansion of a coal-fired generation plant complex in Alberta has recently been completed (EPCOR, 2001). The Project would include adding a 450MW coal-fired station to an existing two-unit complex generating 762 MW. The assessment of potential impacts concludes that cumulative emissions of SO₂, NO₂, potential acid input, and heavy metals would cause an insignificant impact to vegetation. Air emissions from the Genesee complex and the Colstrip units exceed predicted emissions from the Project; hence, it can reasonably be concluded that impacts to vegetation from Project emissions would be low.

Fugitive dust from handling and storage of coal, fly ash, and lime could adversely affect offsite vegetation by changing surface soil temperatures or by depositing deleterious materials on plants or in the soil. Control measures implemented during operations would limit the quantity of coal, fly ash, or lime blown offsite. These control measures include silo storage for lime, enclosed

transfer houses and crusher, enclosed coal conveyor, and lowering the coal stacker to reduce coal drop distance. Blowing fly ash from the disposal cells would be controlled by watering and/or by armoring the surface with coarser bottom ash.

Threatened and Endangered Species

No threatened, endangered, or sensitive plant species or unique vegetation communities are known to occur within 10 miles of the Generation Plant Study Area (Montana Natural Heritage Program, 2002b). State-listed plant species of concern were not identified within the Bull Mountains Mine study area to the east of the Generation Plant Study Area (Western Technology and Engineering, Inc. 1991) and, given the similarity of vegetation types between the Mine area and the Generation Plant Study Area, suitable habitat for plant species of concern is not expected within areas that could be affected by the construction and operation of the Generation Plant. As such, no unique vegetation communities would be affected by the Generation Plant.

Noxious Weeds

Noxious weeds are often early-successional, pioneer species that are very successful at colonizing disturbed areas. They typically produce large quantities of easily dispersed seeds that establish quickly and grow to out-compete native plant species for water, nutrients, and other resources. They may also spread vegetatively following disturbance. Once introduced into an area, these species can invade intact vegetative cover and displace native plants. The four species of noxious weeds present in the Generation Plant Study Area—spotted knapweed, Canada thistle, houndstongue, and field bindweed—could expand onto areas disturbed by the Generation Plant construction and operation. Species of noxious weeds not currently present could be introduced during construction and operation by contaminated equipment or vehicles. The expansion of noxious weed populations or the introduction of new species of noxious weeds would be a high impact as noxious weeds pose the single greatest threat to native vegetation habitats in the West (Duncan, 2001). Disturbed areas can serve as conduits for the spread or establishment of noxious weeds. The Montana County Noxious Weed Control Act requires that landowners or managers control noxious weeds. Developing and implementing a noxious weed management plan, in consultation with Musselshell and Yellowstone counties, would help reduce the impacts of noxious weeds.

Table 4-20 Summary of Impacts on Vegetation from Construction and Operation of the Generation Plant

Impact	Impact Level	Rationale
Long-term loss of vegetation cover, production and diversity on 199 acres at the facility site.	Moderate	The size of the impact area and long-term loss of vegetation is a moderate impact, however, vegetation types affected are extensive in the Bull Mountains.
Short-term loss of vegetation cover, production, and diversity on 8 acres of construction workspace.	Low	The relatively small size of the construction workspace and short duration of impacts before revegetation would limit impacts.

Impact	Impact Level	Rationale
Reduced cover, production, and diversity on surrounding vegetation from facility emissions.	Low	Emission control technology would reduce emissions resulting in low impacts to vegetation.
Reduced cover, production, and diversity on surrounding vegetation from blowing fly ash, lime, or coal dust.	No impact	Fly-ash and coal dust emissions would be controlled by special handling procedures including sprinkling and, in the case of fly-ash, armoring with coarser-textured bottom ash. Ineffective control technology could result in offsite impacts.
Special status plant population loss.	No impact	No special-status plants are known to occupy the Project area.
Loss of unique vegetation communities.	No impact	No unique plant communities are known to occur within or adjacent to the Project area.
New or expanded weed infestations.	No impact	The applicant would be required to control noxious weeds pursuant to the Montana County Noxious Weed Control Act. Lack of weed control could result in a high impact.

Table 4-21 Affected Acres by Vegetation Type for the Generation Plant Study Area

Map Unit	Vegetation Type	Affected Acres	
		Short-Term	Long-Term
	Grassland	2	61
12	Green needlegrass/ Western wheatgrass <i>Stipa viridula/ Agropyron smithii</i>	--	7
13	Needle-and-thread/ Western wheatgrass <i>Stipa comata/ Agropyron smithii</i>	2	54
	Shrub/Grassland	--	7
21	Silver sagebrush/Green needlegrass <i>Artemisia cana/Stipa viridula</i>	--	1
22	Western snowberry/Silver sagebrush <i>Symphoricarpos occidentalis/Artemisia cana</i>	--	<1
23	Western snowberry/ Kentucky bluegrass <i>Symphoricarpos occidentalis/Poa pratensis</i>	--	6
26	Skunkbush sumac/ Needle-and-thread <i>Rhus aromatica/Stipa comata</i>	--	<1
	Ponderosa Pine Savannah and Forest	2	33

Map Unit	Vegetation Type	Affected Acres		
		Short-Term	Long-Term	
31	Ponderosa pine/Bluebunch wheatgrass	<i>Pinus ponderosa/Agropyron spicatum</i>	2	31
32	Ponderosa pine/Green needlegrass	<i>Pinus ponderosa/Stipa viridula</i>	--	2
34	Ponderosa pine/Western snowberry	<i>Pinus ponderosa/Symphoricarpos occidentalis</i>	--	<1
Burned Ponderosa Pine			4	65
41	Burned Ponderosa pine/ Bluebunch wheatgrass	Burned <i>Pinus ponderosa/ Agropyron spicatum</i>	3	31
44	Burned Ponderosa pine/Western snowberry	Burned <i>Pinus ponderosa/Symphoricarpos occidentalis</i>	1	2
45	Burned Ponderosa pine/Common chokecherry	Burned <i>Pinus ponderosa/ Prunus virginiana</i>	--	<1
Agricultural Land			--	33
50	Go-back Hay Meadow	<i>Gutierrezia sarothrae/ Artemisia frigida</i>	--	33
Total Disturbance			16	370

Source: Bull Mountain Development Company, LLC., 2002a.

161kV Transmission System

The Transmission System Study Area is primarily located in uplands; however, several small drainages may be crossed. Generally, the corridor is located in high areas where intersecting ephemeral channels drain small catchment areas. Small wetland/riparian areas may be associated with some of these ephemeral drainages. Other wetlands may be located along the corridor generally associated with springs, seeps, stock watering ponds, and intermittent streams. Mitigation measures including utilizing existing access roads and engineering and locating Transmission System structures to span drainages would reduce impacts to a minimum. Other mitigation measures listed below as well as those listed in Section 2.2.5 would further reduce or eliminate potential impacts to wetlands and riparian areas.

Long-term loss of native vegetation due to access road construction would be a moderate impact, although these vegetation types are common in the area and acreage affected is small relative to the extent of the types in the Bull Mountains. Short-term loss of native vegetation would result in

a low impact assuming revegetation efforts are successful. Revegetation of temporary workspace and other areas would reduce impacts, although diversity (number of species and presence of woody plants) would be reduced in revegetated areas.

No threatened, endangered, or sensitive plant species or unique vegetation communities are known to occur within the Transmission System Study Area (Montana National Heritage Program, 2002b). State-listed plant species of concern were not identified within the Bull Mountains Mine study area to the east of the Generation Plant Study Area (Western Technology and Engineering, Inc. 1991) and, given the similarity of vegetation types between the Mine area and Transmission System Study Area, suitable habitat for plant species of concern is not expected within areas that could be affected by the construction and operation of the Transmission System. No unique vegetation communities would be affected by the Transmission System.

Although detailed weed surveys have not been conducted in the Transmission System Study Area, the four species of noxious weeds present in the Generation Plant Study Area—spotted knapweed, Canada thistle, houndstongue, and field bindweed—could be present and could expand onto areas disturbed by the Project. Species of noxious weeds not currently present could be introduced during construction and operation by contaminated equipment or vehicles. The expansion of noxious weed populations or the introduction of new species of noxious weeds would be a high impact as noxious weeds pose the single greatest threat to native vegetation habitats in the West (Duncan 2001). Utility corridors, including roads, railroads, and power lines, can serve as conduits for the spread or establishment of noxious weeds. The Montana County Noxious Weed Control Act requires that landowners or managers control noxious weeds. The Project would actively control noxious weeds on the property by developing a Noxious Weed Management Plan in consultation with Musselshell and Yellowstone counties or by contracting with the counties for weed control.

4.5.3 Action Alternatives

Landfill Alternative

Potential impacts from the alternative to expand the on-site landfill would be similar to those described for the Proposed Action. There would be a long-term loss of vegetation in the area to be expanded. Long-term loss of native vegetation would be a moderate impact, although these vegetation types are common in the area and acreage affected is small relative to the extent of the types in the Bull Mountains. No threatened, endangered, or sensitive plant species or unique vegetation communities are known to occur within 10 miles of the Generation Plant Study Area for the alternative (Montana Natural Heritage Program. 2002b).

230kV Transmission System

Impacts to vegetation and wetlands associated with the alternative to construct and operate a 230kV Transmission System would be similar to the impacts described for the Proposed Action (161kV system). Road construction or improvement, and ground disturbance resulting from site preparation and right-of-way clearing would be less with the 230kV Transmission System because of the need for fewer structures per mile of transmission line. Following construction,

implementation of mitigation measures listed below including weed control, erosion control, and revegetation would reduce impacts to a low level.

4.5.4 Mitigation Measures

Because there are no federally listed plant species in the Generation Plant or Transmission System Study Areas, there is no mitigation enforceable by a federal agency relating to sensitive plant species.

The Montana County Noxious Weed Control Act is the state law that provides legal directions to counties with regard to weeds. It is unlawful for any person to permit any noxious weed to propagate or go to seed on his or her land. In addition, most counties in Montana have a county weed board that would enforce state regulations providing for the control of weeds. Coordination with both Yellowstone and Musselshell counties would take place in developing the weed control plan to mitigate impacts from noxious weeds.

Prior to construction, the Project would request a jurisdictional determination from the U.S. Army Corps of Engineers to confirm that no jurisdictional wetlands occur in the Transmission System Study Area, and thus no 404 permit would be required.

The regulatory agency does not have the authority to create mitigation measures that they can enforce, without the direct consent of the Project proponent. Potential mitigation measures to further reduce or eliminate impacts to botanical resources and wetlands are included in Chapter 2, Section 2.2.5 in the Botanical Resources and Wetlands subsection. Measures include limitations on vegetation clearing during construction, revegetation of those areas temporarily disturbed during construction and avoidance of streams, drainages, and wetland areas. These measures would minimize loss of vegetation as a result of the Project. Mitigation proposed for other resources also listed in section 2.2.5 would further reduce or eliminate impacts to botanical resources and wetlands.

4.5.5 No-Action Alternative

Under the No-Action alternative, the Project would not be built; therefore, no impacts to botanical resources and wetlands would occur as a result of the Project.

4.6 Wildlife Resources

This section describes the types of impacts that would potentially occur to wildlife resources from construction, operation and maintenance of the Project, and alternatives as described in Chapter 2. Mitigation measures and Project design used to reduce or eliminate potential impacts to wildlife resources are also discussed.

4.6.1 Methods

In order to assess impacts to wildlife resources resulting from the Project or alternatives to the Project, the proposed construction, operation and maintenance activities were reviewed. Information was obtained from the Supplemental EIS Support Document (Bull Mountain Development Co., LLC, 2002a) for background information. The Bull Mountains Mine FEIS

(Montana Dept. of State Lands, 1992) and the Railroad Spur Checklist EA (DNRC, Trust Land Management Division, 2002) were also used as references for the assessment of wildlife. A professional determination was made of how the Project and alternatives would potentially impact wildlife resources based on the occurrence of known populations and potential for sensitive species to occur in the area.

Impact Levels

Impacts from construction and operation of the Project on wildlife resources could be temporary (less than one year), short-term (one year to four years, or completion of construction), or long-term (longer than four years).

Impacts would be classified in this document as high if they result from actions that:

- Cause the ‘take’ of federally listed, endangered, threatened, candidate or proposed species.
- Cause long-term loss of habitat that would result in increased mortality or lowered reproductive success for entire species or populations of a species.
- Cause the long-term inability of fish and wildlife to use biologically important habitats, such as spawning areas, breeding areas or winter range.
- Harm or kill a significant number of individuals of a common wildlife species

Impacts would be classified in this document as moderate if they result from actions that:

- Create an effect on federally listed or proposed threatened or endangered wildlife species that could be partially mitigated.
- Cause a reduction in the population, habitat, or viability of a federal or state listed wildlife species of concern or sensitive wildlife species, without resulting in trends towards endangerment or the need for federal listing.
- Harm or kill a small number of individuals of a common wildlife species.

Impacts would be classified in this document as low if they result from actions that:

- Create an effect on federally listed or proposed threatened or endangered wildlife species that could be largely or completely mitigated (i.e., seasonal restrictions on construction activities) or are temporary and benign (i.e., temporary disturbance by construction noise).
- Cause a minor short-term (less than two years) reduction in the quantity or quality of the habitat of a federal or state listed wildlife species of concern or sensitive wildlife species, without resulting in trends towards endangerment and/or the need for federal listing.
- Cause a short-term (less than one year) reduction in the quantity or quality of habitat critical to the survival of local populations of common wildlife species.

No impacts would occur when an action has no effect or fewer impacts than the low impact level on wildlife habitat, populations, or individuals.

4.6.2 Proposed Action

Temporary impacts from the Proposed Action would potentially result from the presence of additional human and vehicle disturbance. There may be temporary displacement of avian species as a result of commotion caused by vehicle traffic and materials loading. Mobile species would simply move away from these activities, although some individuals (e.g., nesting birds, small mammals, reptiles, amphibians, and invertebrates) could be vulnerable to direct mortality. Temporary and short-term impacts could occur due to the loss of habitat in landfill space and other temporary-use areas that would be re-vegetated after construction or use was complete.

Long-term impacts would result from permanent disturbance such as tower locations, plant site, access roads, and long-term landfill footprints. Temporary impacts could become long-term if re-vegetation of these areas was unsuccessful or resulted in the introduction or spread of noxious weeds.

Generation Plant

Long-term impacts would occur on those portions of the Generation Plant site that would not be re-vegetated. The habitats that would be affected by construction and operation of the generation plant are listed in Chapter 3. These habitats are common and widespread in the Bull Mountains and over much of the Generation Plant Study Area.

Flashing lights associated with the generation plant could contribute to the overall avoidance of the site by wildlife. However, flashing lights or other activities may reduce the potential for collision impacts to flying birds. Minor beneficial impacts may occur, particularly to wildlife species that are habituated to human activity, as a result of creation of sediment ponds (e.g., use by breeding amphibians, waterfowl, or other wildlife) or micro site habitats associated with the plant facilities. Temporary impacts along transportation routes would potentially result from vehicular traffic as materials are transported from the landfill to the Mine or other locations.

Indirect impacts to wildlife resources could occur during construction and operation of the Generation Plant as the result of vehicle/wildlife collisions, illegal or unintentional killing or harassment of wildlife, or increased human occupation of the Bull Mountains. While construction and operation of the Generation Plant would not benefit wildlife, impacts to wildlife or habitat resulting from construction and operation of the Generation Plant would be low.

Because of their absence from the Generation Plant site, there would be no impacts to federally listed threatened and endangered species or to state or federal species of concern.

161kV Transmission System

Long-term impacts could occur on those portions of the Transmission System Study Area that would not be re-vegetated such as tower locations or access roads.

Indirect impacts to wildlife resources could occur during construction and operations of the 161kV Transmission System as the result of vehicle/wildlife collisions, illegal or unintentional harvest or harassment of wildlife, or increased human occupation of the area; however, presence of people and vehicles would not be expected to substantially change as a result of construction of the 161kV Transmission System.

Because much of the Transmission System would be constructed in open areas that may be lacking in perching opportunities for raptors, indirect impacts could include increased predation by raptors on sage and sharp-tailed grouse, as well as other birds, small mammals and reptiles, due to an increase in perching opportunities created by the transmission poles. Additionally indirect impacts could include bird collisions with conductors and/or guy wires.

While construction and operation of the 161kV Transmission System would not substantially benefit wildlife, impacts to wildlife or habitat resulting from construction and operation of the 161kV Transmission System would be low.

Because of their absence from the 161kV Transmission System, there would be no impacts to federally listed threatened or endangered species or to state or federal species of concern.

4.6.3 Action Alternatives

Landfill Alternative

Direct and indirect, as well as short- and long-term impacts to wildlife and habitat for the landfill expansion, are similar to those presented for the Proposed Action. Loss of some additional habitat would result from this alternative with the additional acreage of landfill required. However, the area identified for additional landfill does not provide habitat for sensitive species and is common to that found elsewhere on land surrounding the Generation Plant Study Area. Impacts to wildlife or habitat resulting from construction and operation of this alternative would therefore be low.

230kV Transmission System

Because the structure footprints and access road disturbance in the 230kV alternative would be similar to the Proposed Action (161kV Transmission System), impacts for the 230kV alternative are comparable to those discussed above for the Proposed Action. The 230kV structures would be 7 to 27 feet taller than the 161kV structures; however, fewer 230kV structures would be required. As a result, less habitat would be permanently removed from the construction of the 230kV alternative.

Indirect impacts during construction and to prey species resulting from increased perching opportunities for raptors would be the same as that described for the 161kV Transmission System. While construction and operation of the 230kV Transmission System would not substantially benefit wildlife, impacts to wildlife or habitat resulting from construction and operation of the 230kV Transmission System would be low.

Because of their absence from the 230kV Transmission System, there would be no impacts to federally listed threatened or endangered species or to state or federal species of concern.

4.6.4 Mitigation Measures

Because there are no federally listed species in the Project, there is no mitigation enforceable by a federal agency.

The regulatory agency does not have the authority to create mitigation measures that they can enforce, without the direct consent of the Project proponent. Potential wildlife mitigation

measures are proposed in Chapter 2, Section 2.2.5 in the Wildlife Resources subsection. These measures include avoiding wildlife harassment during construction by equipment and workers. In addition, employees would be encouraged to follow established vehicle operation procedures, including speed limits.

Mitigation steps to control raptor predation and prevention devices or towers designed to prevent raptor perching, may be recommended by MFWP to reduce predation on sharp-tailed grouse in key habitat areas. Sharp-tailed grouse have been recorded in the Transmission System Study Area and are particularly susceptible to predation by raptors during spring breeding/strutting when they become inattentive to potential predators. One or more leks are considered likely. However, there are no known leks in the Transmission System Study Area.

Measures proposed for other disciplines, particularly water quality, air quality, and vegetation, would also minimize impacts to wildlife habitats.

4.6.5 No-Action Alternative

Under the No-Action alternative, the Project would not be built. There would be no direct, indirect, or cumulative effects to wildlife resources. Any environmental effects currently affecting wildlife at or near the Project would not be expected to change.

4.7 Fisheries and Aquatic Resources

4.7.1 Methods

In order to assess the impacts to fisheries and aquatic resources from the Project, the proposed construction, operation and maintenance activities as described in Chapter 2 were reviewed. Information was obtained from the Supplemental EIS Support Document (Bull Mountain Development Co., LLC, 2002a), the Bull Mountains Mine FEIS (Montana Dept. of State Lands, 1992) and the Railroad Spur Checklist EA (DNRC, Trust Land Management Division, 2002) for this assessment. A professional determination, based on the locations and type of surface water, was made for how these activities may impact fish and aquatic resources.

Impact Levels

Impacts would be classified in this document as high if they result from actions that:

- Cause the ‘take’ of federally listed, endangered, threatened, candidate or proposed species.
- Cause a significant long-term (more than two years) adverse effect on the populations, habitat, and/or viability of a federal or state listed fish species of concern or sensitive species, which would result in trends towards endangerment and/or the need for federal listing.
- Harm or kill a significant number of individuals of a common fish species at the local (stream reach or small watershed) level.

Impacts would be classified in this document as moderate if they result from actions that:

- Would, without causing a ‘take’, cause a temporary (less than two months) reduction in the quantity or quality of localized (stream reach or small watershed) aquatic resources or habitats at a time when federally listed threatened, endangered, or proposed fish species are not likely to be present (i.e., during non-spawning or rearing times).
- Cause a short-term (up to two years) localized (stream reach or small watershed) reduction in population, habitat, or viability of a federal or state listed fish species of concern or sensitive species, without resulting in trends towards endangerment or the need for federal listing.
- Harm or kill a small number of individuals of a common fish species at the local (stream reach or small watershed) level.

Impacts would be classified in this document as low if they result from actions that:

- Cause a temporary (less than two months) localized (stream reach or small watershed) reduction in the quantity or quality of aquatic resources or habitats of state listed fish species of concern or sensitive species, without causing a trend towards endangerment and the need for federal listing.
- Cause a short-term (up to two years) disturbance or displacement of common fish species at the local (stream reach or small watershed) level.

No impacts to fish or aquatics would occur when an action has no effect or fewer impacts than the low impact level on habitat, populations, or individuals.

4.7.2 Proposed Action

Generation Plant

Because there are no standing or flowing waters in the Generation Plant Study Area, no occupied or potential fisheries habitat would be removed by construction and operation of the plant. Sediment ponds would be constructed and maintained to capture runoff during construction and operation of the Project, so that sediment from the site would not be expected to enter Rehder or Halfbreed creeks. Neither of these streams apparently supports a substantial fishery; the nearest such fishery is in the Musselshell River, over 16 drainage miles down Halfbreed Creek from the Generation Plant Study Area. Consequently, construction and operation of the Generation Plant would not be expected to have any impacts to fishery resources.

161kV Transmission System

Because there are no standing or flowing waters in the Transmission System Study Area, no occupied or potential fisheries habitat would be removed by construction and operation of the 161kV Transmission System. Consequently, construction and operation of the 161kV Transmission System would not be expected to have any impacts to fishery or aquatic resources.

4.7.3 Action Alternatives

Landfill Alternative

Impacts to fishery resources from construction and operation of the landfill expansion alternative are identical to those presented for the Proposed Action. Because of the absence of fisheries and/or aquatic habitat in the Project area there would be no impacts to fisheries or aquatic resources resulting from construction and operation of the landfill expansion alternative.

230kV Transmission System

Because the tower footprint and access road disturbance in the 230kV Transmission System would be similar to the 161kV Transmission System for the Proposed Action, impacts for the 230kV alternative are similar to those addressed in the Proposed Action. The 230kV Transmission System would require slightly taller structures but would have wider spans with fewer structures required. Construction and operation of the 161kV Transmission System alternative would not be expected to have any impacts to fishery and aquatic resources.

4.7.4 Mitigation Measures

Because there are no fishery or aquatic resources impacted by the Project, there are no mitigation measures that are enforceable by an agency or recommended.

4.7.5 No-Action Alternative

Under the No-Action alternative, the Project would not be built. There would be no direct, indirect, or cumulative effects to fisheries resources. Any environmental effects currently occurring to streams such as Halfbreed Creek would not be expected to change.

4.8 Cultural Resources

4.8.1 Methods

Cultural resource impacts as a result of the Project were determined by reviewing the proposed construction, operation and maintenance activities as described in Chapter 2. Information was obtained from the Supplemental EIS Support Document (Bull Mountain Development Co., LLC, 2002a) for background information. The Bull Mountains Mine FEIS (Montana Dept. of State Lands, 1992) and the Railroad Spur Checklist EA (DNRC, Trust Land Management Division, 2002) were also used as references for cultural resource assessments. A professional determination of Project impacts was made based on the locations of cultural resources as described in Chapter 3.

Impact Levels

In terms of changes to visual setting, impacts could occur only if:

- The cultural resource is eligible to the National Register, potentially eligible, or unevaluated, and

- If visual setting contributes to the resource's National Register eligibility

For cultural resources that meet these two criteria, visual impacts would be considered high if the cultural resource is within a 1.0-mile radius of the proposed chimneys. Impacts would be considered moderate if the cultural resource is from 1.0 to 2.0 miles of the proposed chimneys. Impacts would be considered low if the cultural resource is from 2.0 to 3.0 miles of the proposed chimneys.

No impact would occur if:

- The cultural resource is not eligible to the National Register,
- The cultural resource is not visually sensitive (e.g. most archaeological sites), or
- The cultural resource is greater than 3.0 miles from the proposed chimneys.

In terms of physical disturbance to cultural resources, impacts could occur only if a cultural resource is eligible to the National Register, potentially eligible, or unevaluated.

For cultural resources that meet this criterion, impacts would be considered high if:

- The cultural resource would be disturbed by construction, operation, and maintenance
- The resource can not be avoided, and
- Mitigation measures, such as data recovery, are not feasible.

Impacts would be considered moderate if:

- The cultural resource would be disturbed by construction, operation, and maintenance
- The resource can not be avoided, and
- Mitigation measures, such as data recovery, are feasible.

Impacts would be considered low if:

- The cultural resource would be only slightly disturbed by construction, operation, and maintenance
- The resource can not be avoided, and
- Mitigation measures, such as data recovery, are feasible.

No impact would occur if:

- The cultural resource is not eligible to the National Register,
- The cultural resource would not be disturbed by construction, operation, or maintenance, or
- The cultural resource can be avoided through Project redesign.

4.8.2 Proposed Action

Generation Plant

Ground Disturbance

Under the Proposed Action, facilities that would disturb the ground would include:

- All buildings, structures, and facilities within the plant site itself. It is estimated that the total area disturbed during construction at the plant would be about 208 acres. Approximately 167 acres would be located within the plant fence, including a construction parking lot and an area for construction trailers, tools, vehicles, equipment, and material construction storage. An additional 40 acres of land would be outside the fenced area for additional Project facilities
- A 4,000-foot-long conveyor belt that would deliver coal to the plant from the Bull Mountains Mine transition point
- A 0.2-mile paved access road extending from Old Divide Road to the plant site
- A 50-foot wide solid waste disposal haul road from the Generation Plant to Bull Mountains Mine
- Four to six groundwater wells and buried water pipelines for the plant water supply

Detailed descriptions of these various aspects of the Proposed Action can be found in Chapter 2.

Within the fenced area at the plant site, only one cultural resource has been identified that would be affected by ground disturbance. This archaeological site, a prehistoric lithic scatter, requires more data before it is possible to evaluate its National Register eligibility (Bull Mountain Development Company, 2002a; Pouley, 2002).

The proposed access road would not affect any cultural resources other than isolated artifacts that are not National Register-eligible (Bull Mountain Development Company, 2002a; Pouley 2002).

The exact locations of the proposed solid waste disposal haul road and the proposed conveyor belt are not finalized. It appears that these facilities could potentially affect a prehistoric lithic scatter that may be National Register eligible. Because some of the land in the vicinity has not been surveyed for cultural resources, other important cultural resources might exist in the area.

Locations of groundwater wells and associated pipelines have not been surveyed for cultural resources. Important cultural resources could exist in these areas.

Visual Setting

The potential for changes in visual setting was evaluated by considering cultural resources within 3.0 miles of the proposed chimneys at the plant site. Under the Proposed Action, each unit of the Generation Plant would have a 574-foot tall chimney constructed of a reinforced concrete outer shell. FAA lighting and marking requirements would be met, as well.

Within 3.0 miles of the proposed 574-foot chimney, 51 cultural resources have been identified. Of these, 48 have been recommended by previous investigators as eligible to the National Register, have not been fully evaluated, or have an unknown eligibility recommendation. Of

these 48, eight resources are considered potentially visually sensitive as a result of the Generation Plant. These include standing log structures, Native American petroglyphs, rock cairns, and rockshelters. The remaining cultural resources are collapsed or destroyed structures and archaeological deposits, none of which are visually sensitive.

A visual impact analysis (see Section 4.3) was performed to determine which of these eight resources were within the viewshed of the proposed chimneys. Table 4-22 lists the resources within the viewshed. Of the 8, the chimneys would be visible from 7.

Table 4-22 Resources Within the Viewshed

Resource Type	Distance from Chimneys
Petroglyphs	< 0.5 mile
Rockshelter	0.7 mile
Rock cairn	1.1 miles
Homestead	1.3 miles
Petroglyphs	1.6 miles
Homestead	1.6 miles
Cabin	2.1 miles

Source: Bull Mountain Development Company, LLC., 2002a.

Most of these resources have not been sufficiently documented to determine whether they are, in fact, eligible to the National Register or whether visual setting is an important aspect of their National Register eligibility. For this analysis, it is assumed that the resources are National Register eligible and that they are visually sensitive.

The petroglyphs and rock cairn may also be Traditional Cultural Property (TCP). The significance of these resources and the nature of adverse effects cannot be fully assessed until the importance of these resources to Native Americans has been determined.

Improved Access

Under the Proposed Action, there would be a 0.2-mile access road to the Generation Plant site. Access to the plant site would be restricted and most of the plant site would be fenced. Therefore, it is unlikely that the presence of the Generation Plant and associated facilities would increase vandalism at major cultural resources.

161kV Transmission System

Under the Proposed Action, transmission facilities include a 161kV Transmission System from the Generation Plant to the Broadview Substation. The system is proposed to parallel the existing Bull Mountain rail corridor from the Generation Plant site and would be 28 miles long and 300 feet wide. Detailed descriptions of the 161kV Transmission System can be found in Chapter 2.

The precise location of ground disturbance from H-poles has not been determined. However, within or near the railroad right-of-way, three cultural resources were identified that were either considered eligible to the National Register or required more data for evaluation (see Metcalf 2002b). These include a lithic scatter, a rock cairn, and a farmstead with no standing buildings. The rock cairn may also qualify as a TCP although this has not been confirmed through Tribal consultation.

During construction and maintenance of the Transmission System, existing access roads would be used wherever feasible. Any new access roads would be restored to their natural condition following construction of the Transmission System. Therefore, construction of the Transmission System would be unlikely to lead to increased vandalism of cultural resources.

4.8.3 Action Alternatives

Landfill Alternative

Ground Disturbance

This alternative differs from the Proposed Action by the presence of a landfill north of the Generation Plant site. This would increase the amount of ground disturbance around the plant site.

The landfill would not affect known cultural resources, but it is possible that undiscovered cultural resources exist in the landfill alternative site since the area may not have been surveyed for cultural resources. Therefore, there is a potential that ground disturbance under this alternative could have greater, but undetermined, impacts on cultural resources than the Proposed Action.

Visual Setting

Although the landfill under this alternative would be close to one cultural resource site that may be visually sensitive, it is not anticipated that the landfill would significantly affect the visual setting.

Improved Access

Access under this alternative would not differ from access under the Proposed Action. As such, impacts to cultural resources as a result of increased vandalism would be low.

230kV Transmission System Alternative

Ground Disturbance

Under this alternative, the only difference from the Proposed Action would be the use of a 230kV Transmission System rather than 161kV. The amount of right-of-way required would be the same. The spans between circuits would be slightly longer, so there would be somewhat less potential for disturbing undiscovered cultural resources. However, it is anticipated that the amount of actual ground disturbance from installing H-poles would be similar to the Proposed Action.

Visual Setting

Visual effects on cultural resources under this alternative would be similar to the Proposed Action with potential for a slight increase in impacts as a result of increased structure height; however the fewer number of structures required for the 230kV system would likely negate this slight increase.

Improved Access

Access under this alternative would not differ from access under the Proposed Action. As such, impacts to cultural resources as a result of increased vandalism would be low.

4.8.4 Mitigation Measures

The regulatory agency does not have the authority to create mitigation measures that they can enforce, without the direct consent of the Project proponent. Recommended mitigation measures to further reduce or eliminate impacts to cultural resources are included in Chapter 2, Section 2.2.5, in the Cultural Resources subsection. Measures include further consultation with the SHPO, as well as additional documentation and evaluation of cultural resource sites associated with the Project.

4.8.5 No-Action Alternative

Under the No-Action Alternative, there would be no ground disturbance that would affect any cultural resources and no visual impacts on cultural resources.

4.9 Visual Resources

Visual resource impacts would result from the construction, operation and maintenance of the Project, specifically, the generation facility and Transmission System. Visual resource impacts were identified as they relate to sensitive viewpoints. Visual impacts can occur when changes in the landscape are noticeable to viewers looking at the landscape from residential viewpoints and travel routes. For issues associated with visibility of atmospheric haze in Class I PSD areas, see section 4.2, Air Resources.

4.9.1 Methods

The visual impacts that would result from the construction and operation of the Project are usually direct, adverse, and long-term. This analysis considers the potential visual impacts of changes in the landscape on:

- Views from residences
- Views from travel routes

Visual Contrast

Visual contrast is the measure of physical change in the existing landscape that would result from introduction of the Project. The addition of new poles, conductors, insulators, and access

roads, would cause visible change in the landscape along the transmission corridor. The addition of Project chimneys, boiler buildings, air-cooled condensers, coal handling equipment, and an electrical switchyard would cause visible change in the landscape within the Generation Plant Study Area. Potential visual impacts were determined by analyzing how visual contrasts are perceived from sensitive viewpoints.

Structure contrast was emphasized over landform and vegetation contrast due to the nature of the Project, the presence of numerous existing access roads, and diminished or declining vegetation found within portions of the transmission corridor.

Structure contrast examines the compatibility of transmission and generation facilities with the existing landscape setting. Structure contrast is strongest where there are no other structures (e.g., industrial buildings/structures or existing transmission structures) in the landscape. For the most part, structure contrast is determined by the presence or absence of existing parallel transmission lines and other large heavy industrial facilities.

Photo Simulations

One area having potential visual impacts was identified and photographed. A photo simulation technique was used to evaluate the accuracy of the predicted visual impacts, to determine the effectiveness of recommended mitigation, and to illustrate the expected impacts to the concerned agencies and the public. The viewpoint from the simulation that was prepared includes one view depicting the proposed Generation Plant. Views from the Generation Plant simulation are looking north.

The photo simulation was created using a combination of computer digital imaging and Computer Aided Drafting and Design (CADD) software. Three-dimensional drawings were combined with a three-dimensional model of the terrain to create an accurate representation of the scale and the perspective of the transmission line and the physical changes in the landscape. The photo simulation is shown in Figure 2-2.

Viewshed Mapping

Seen area mapping, also known as view shed mapping, is a computer-derived analysis showing areas visible from inventoried viewpoints. A GIS uses point, line, or polygon information to analyze and perform this function. The results of the analysis are verified through site visits and other overlay mapping to account for such features as vegetation and localized conditions. The result is a detailed map showing areas visible from inventoried viewpoints.

Visual influence mapping of the Project's chimneys was conducted within five miles of the Project. To determine the visual influence of the Project chimneys, two analysis points were placed at separate points along the Project's chimneys. One point was placed at 515' while another point was placed at 308'. This method revealed both the visibility of sections near the top of the chimneys as well as sections near the middle. This method also determines if viewpoints nearby can see either just the top of the chimneys or from the middle all the way to the top of the chimneys.

Visibility mapping was conducted within two miles of all other Project facilities. The mapping was done to determine what sensitive viewpoints could see all of the Project facilities from the

ground to the top of the boiler building and other appurtenant structures. As stated earlier, views of the chimney were assessed differently.

Impact Assessment Process

The potential effects of the visual contrasts associated with the Project are described in terms of visual impacts to viewers. The initial visual impact assessment was determined by analyzing the visibility of contrasts that would be caused by the Project from sensitive viewpoints. See Tables 4-23 through 4-24 for a summary of the impact assessment process.

Table 4-23 Distance Zones

Distance Zone	Distance	Visibility Threshold
Foreground (FG)	0-½ mile	High
Middle Ground (MG)	½ - 1 mile	Moderate
Background (BG)	1-5 miles	Low

Table 4-24 Viewer Impacts

Visual Sensitivity	Visual Contrast Level								
	S			M			W		
	Distance Zone			Distance Zone			Distance Zone		
	FG	MG	BG	FG	MG	BG	FG	MG	BG
H	H	H	M	M	M	L	M	M	L
M	M	M	L	M	M	L	L	L	L

Distance Zones: FG=Foreground MG=Middle Ground BG=Background

Visual Contrast Level: S=Strong M=Moderate W=Weak

Viewer Impacts: H = High M = Moderate L = Low

Impact Levels

To assess the *initial* visual impacts of the Project, the following set of criteria was used.

Impacts would be classified in this document as high where:

- The Project would become a view’s dominant feature or focal point.
- Several high sensitivity viewers would see the Project predominately in the foreground and middle ground distance zone.

Impacts would be classified in this document as moderate where:

- The Project would be clearly visible but not the dominant feature of the view.
- Several high and/or moderate sensitivity viewers would see the Project mostly within the middle ground distance zone.

Impacts would be classified in this document low where:

- The Project would be visible but not evident in the view.
- Views of the Project from either high and/or moderate sensitivity viewpoints would be screened or predominately seen in the middle ground and background distance zone.

4.9.2 Proposed Action

The visual impacts stated in this section are considered residual and have been assessed after mitigation measures have been applied.

Generation Plant

Visual Contrast

When completed, the Generation Plant would be a noticeable addition to the local landscape, which is otherwise predominantly rural. The most noticeable components would be the two main chimneys, each 574 feet high, and the one large boiler building, approximately 250 feet high. Other noticeable components would include the air-cooled condensers, air pollution control equipment, coal handling equipment, and electrical switchyard. As much as possible, the plant buildings and equipment would be designed to blend into the landscape. Buildings colors would be predominantly neutral tans and grays. As indicated by the visual simulation presented in Figure 2-2, the plant would be an obvious, dominant feature in the landscape. The visual contrast created by the Project would be strong.

Project Visibility from Sensitive Viewpoints

Views of the Project's chimneys vary from expansive to limited, depending on local topography and the presence or absence of surrounding vegetation, see Table 4-25, Visual Influence of Project Chimneys.

Table 4-25 Visual Influence of Project Chimneys

High Sensitivity Viewpoints		Project Visibility			
Number of Visually Sensitive Cultural Sites	Number of Houses	Distance Zone	Top of Chimney Visibility	Combination of Middle and Top Visibility	No Visibility of Project Chimneys
N/A	1	0 to ½ mile		✘	
2	7	½ to 1 mile		✘	
3	141	1 to 5 miles		✘	
2	26	1 to 5 miles	✘		
1	105	1 to 5 miles			✘

Short Term Impacts

Impacts would occur during the 4-year construction period due to the presence of equipment, materials, and work crews, along with the dust raised by construction activities. Earthmoving activities, followed by erection of chimneys and buildings, and the presence of large construction cranes, would be the most noticeable elements. The daily presence of up to 800 construction workers would also contribute to noticeable change at the site. These impacts would be noticeable to local residents and travelers on local roads, and they would be somewhat noticeable to travelers on U.S. Route 87. However, the impacts would be short term and intermittent. Overall, visual impacts due to construction are considered low due to the short duration.

Long Term Impacts

The visual impacts from the operation of the Project would be direct and long-term. The Generation Plant facility would be very noticeable to local residents and travelers on local roads. It would also be noticeable to travelers on U.S. Route 87 intermittently, when not screened by hills or trees, see Figure 3-6. Specifically, one residence would have clear views of the generation facility within the foreground distance zone. This view of the Project would be dominant and would be considered a focal point resulting in a high visual impact. This is a limited quantity (1) of affected viewpoints that would have Project views within the foreground distance zone. Seven residences would have views of the generation facility within middle ground distance zone. These views of the Project would be clearly visible but not the dominant feature of the view resulting in a moderate impact due to the limited quantity (7) of affected viewpoints that would have Project views within this distance zone. Ten residences would have views of the generation facility within the background distance zone. These views of the Project

would be visible but not evident in the view resulting in a low impact due to the limited quantity (10) of affected viewpoints that would have Project views within this distance zone. Motorists traveling U.S. Route 87 would have views of the generation facility within the middle ground distance zone. These views of the Project would be clearly visible but not the dominant feature of the view resulting in a moderate impact due to the moderate sensitivity of road viewers that would have Project views within this distance zone.

The top half of the Project chimneys would be visible to travelers on U.S. Route 87 nearest the Project site within the middle ground distance zone. The top half of the Project chimneys would also be visible from one residence within the foreground distance zone as well as seven residences within the middle ground distance zone and 141 residences within the background distance zone. With the exception of one viewer located in the foreground distance zone, views of the Project chimneys would not be the focal point of the views discussed. The Project chimney views, however, would range from clearly visible to not evident in view dependant upon a viewers distance from the Project chimneys. Visual impacts are considered moderate, because they would be restricted to a limited local area with low population density. This localized area would have views of the Project chimneys that would be dominant within the foreground and clearly visible within the middle ground distance zones.

Long-term impacts also could result from strobe lights or other aviation safety lighting on the main chimneys. The intensity and flashing of strobe lights during operation at night would result in additional moderate impacts to surrounding viewers. The Project developer plans to work with the Federal Aviation Administration (FAA) to identify chimney lighting that would have the least impact on local residences and other viewers, consistent with aviation safety considerations. If the marking recommendation from the FAA is the installation of strobes and the lights are installed with baffles, visual impacts from the strobe lighting would decrease. Baffled strobe lights would direct the lighting upward rather than outward (Riley, 2001).

In-Mine Waste Disposal

In-Mine Waste Disposal would result in low to non-identifiable visual impacts from the presence of additional haul roads, truck traffic and potential dust visible in the foreground and middle ground distances zones from viewpoints described under the Generation Plant, long-term impacts.

161kV Transmission System

Visual contrast that would result from the construction and operation of the 161kV Transmission System would be strong where the Transmission System would not parallel other transmission lines from MP 0 to 23.6, see Figure 2-11. Where the Transmission System would parallel the northern circuit of the Colstrip to Broadview 500kV transmission line from milepost 23.6 to 28, visual contrasts would be moderate to weak.

Visual impacts would be moderate from MP 0 to 23.6 where 24 residences would have foreground to middle ground views of the 161kV Transmission System. Visual impacts would be low from MP 23.6 to 28 where one residence would have foreground to middle ground views of the 161kV Transmission System.

4.9.3 Action Alternatives

Landfill Alternative

The landfill alternative for waste disposal would result in low visual impacts from the presence of additional haul roads, truck traffic and potential dust visible in the foreground and middle ground distances zones from viewpoints described under Generation Plant, long term impacts. When compared to the proposed action, the expansion of the landfill would be more noticeable in views of the Project within the foreground and middle ground distance zones.

230kV Transmission System

Visual contrast that would result from the construction and operation of the 230kV Transmission System would be strong where the Transmission System would not parallel other transmission lines from MP 0 to 23.6, see Figure 2-11. Where the Transmission System would parallel the northern circuit of the Colstrip to Broadview 500kV transmission line from milepost 23.6 to 28, visual contrasts would be weak.

The impacts that would result from the 230kV Transmission System would differ slightly from the proposed action of the 161kV Transmission System. The visual contrasts associated with the introduction of 80-foot tall H-frame structures along the route are nearly identical to the 161kV system because both structures are of the same size and similar design. One difference with the 230kV Transmission System is that it would have one less circuit visible resulting in slightly weaker visual contrasts, see Figure 2-11. Another difference is that the 230kV alternative would have longer spans than the 161kV system. These longer spans would result in slightly less visual contrast when compared to the visual contrast of the 161kV system.

Visual impacts would be moderate from MP 0 to 23.6 where 24 residences would have foreground to middle ground views of the 230kV Transmission System. Visual impacts would be low from MP 23.6 to 28 where one residence would have foreground to middle ground views of the 230kV Transmission System.

4.9.4 Mitigation Measures

No Project mitigation measures specific to visual resources are enforceable by an agency. The regulatory agency does not have the authority to create mitigation measures that they can enforce, without the direct consent of the Project proponent.

Potential mitigation measures to further reduce or eliminate impacts to visual resources are included in Chapter 2, Section 2.2.5 in the Visual Resources subsection. Measures include altering the appearance of some Project structures to allow for less visual intrusion and minimizing ground disturbance during construction that would create noticeable changes to the landscape.

The effectiveness of the mitigation measures for visual resources are primarily found in measures VR-2, VR-5 and VR-6. Measure VR-2 would reduce the visual contrast and reflected light from the transmission structures. Measure VR-2 would be utilized along the entire Transmission System from MP 0 to 28. Measure VR-2 would help to blend the transmission structures into the woodlands that occur from MP 0 to 9. The application of Measure VR-2 from

MP 9 to 28 also assists to give the structures a more natural appearance. Measure VR-5 would reduce any reflected light from the transmission conductors. Measure VR-6 would reduce visual contrasts associated with vegetation clearing that would be necessary for the Generation Plant construction or Transmission System construction and operation. Measure VR-6 would be utilized from MP 0 to 9 along the Transmission System where the corridor would pass through ponderosa pine woodlands. Since the generation facility would be painted in neutral grays and tans, a specific mitigation measure isn't necessary to reduce reflected light or glare from the facilities. The neutral tans and grays would assist the generation facility, with the exception of the Project chimneys, to blend into the colors and hues seen in the surrounding natural landscape, see Figure 2-2. If strobe lights were required by the FAA, Measure VR-7 would reduce visual contrasts seen by local residences.

4.9.5 No-Action Alternative

Under the No-Action alternative, visual impacts would be low to non-identifiable. No large industrial buildings or Project chimneys would be visible from local residential viewpoints or motorists traveling a portion of U.S. Route 87 within the Generation Plant Study Area. Transmission structures and conductors would not be visible from residential viewpoints along the proposed Transmission System route resulting in no visual impacts along this corridor.

Views of rail traffic traveling upon the proposed railroad spur would increase under the No-Action alternative. The Project would not consume coal under this alternative, although coal would still be shipped to outside markets via the railroad spur. Although the visual impacts would be temporal, coal train operation would be visible particularly in the western two-thirds of the railroad spur where the landscape is flat to rolling and views are expansive and open from MP 9-28 along the parallel Transmission System corridor. Views of the temporal passing of increased coal train traffic along the railroad spur would result in a low to non-identifiable visual impact.

4.10 Noise

4.10.1 Methods

Sensitive receptors near the Project were identified and were mapped in Chapter 3 (Figure 3-7). Impacts on these sensitive receptors from noise levels as a result of the Project equipment and associated facilities, were assessed using calculations developed in accordance with the International Organization for Standardization (ISO) Standard 9613, (ISO 1996). This standard specifies the calculations to determine the reduction in noise levels due to the distance between a noise source and a receptor, the effect of the ground on the propagation of sound, the influence of air absorption, and the effectiveness of natural barriers due to grade or of man-made barriers, such as walls and buildings.

Although the Project is in the preliminary design phase, a preliminary list of equipment, based on a similarly sized coal-fired generation plant and associated facilities, was provided (Sargent & Lundy, 2002b). This information included data on the expected operating conditions and equipment sizes and quantities. Noise control measures (such as duct insulation and separate fan enclosures along with inlet silencers and buildings with insulated wall as well as enclosures for

equipment) for a typical coal-fired generation plant design were assumed for the noise level calculations.

Typical noise data for the associated Mine, construction and railroad equipment used in the noise level predictions were estimated based on noise emission equations from a variety of publications (Beranek 1992, Crocker, 1997, EEI, 1984, ISO, 1996, DOT, 1995). Since the design and engineering of the Project facilities and the selection of the equipment have not been finalized at this time, the predicted noise levels should be considered approximate, but reasonably accurate.

This section also includes information extracted from the Supplemental EIS Support Document (Bull Mountain Development Co., LLC, 2002a) and the Bull Mountains Mine FEIS (Montana Dept. of State Lands, 1992).

According to the EPA, outdoor yearly noise levels are sufficient to protect public health and welfare if they do not exceed 55 dBA on the L_{dn} scale in sensitive areas (e.g., residences, schools, and hospitals). EPA found that outdoor L_{dn} values greater than 55 dBA can cause sleep disturbance, annoyance, and stress, maintaining an L_{dn} noise level of 55 dBA outdoors should ensure adequate protection for indoor living. Because these protective levels were derived without concern for technical or economic feasibility, and contain a margin of safety to ensure their protective value, EPA has indicated that they should not be viewed as standards, criteria, regulations, or goals. Rather, they should be viewed as levels below which there is no reason to suspect that the general population would be at risk from any of the identified effects of noise. The EPA outdoor recommended level of L_{dn} 55 dBA is commonly accepted as a target to prevent impacts at residences due to noise.

A noise level increase of approximately 6 dBA typically appears to be a “clearly noticeable” increase, an increase of 10 dBA appears to be approximately twice as loud as the original noise level to a person with normal hearing, and an increase of 20 dBA appears to be about four times as loud as the original noise (Egan 1988). Noise impacts would be considered high if the predicted Project noise levels exceed the suggested Federal target levels by 15 decibels (dBA) or greater. Noise impacts would be considered moderate if the day-night noise level (L_{dn}) at a receptor were between 5 and 15 dBA. Noise levels would be considered low if the day-night noise level (L_{dn}) at a receptor were between 0 and 5 dBA. These criteria are adapted from the state highway administrations, Criteria 1, definitions.

Five noise-sensitive receptors, representing single residences, the Shining Mountain Christian Ranch, the Bull Mountains Community Church, and groups of residences, within 1.5 miles of the Project facilities were assessed (see Section 3.10.3). The receptor locations are shown in Figure 3-7. Long-term noise impacts to sensitive receptors due to operation of the Project would be considered the most significant.

Impact Levels

Impacts would be classified in this document as high where an action would:

- Increase noise levels by > 15 dBA above the federal range, thereby being an annoyance and creating an adverse reaction.

Impacts would be classified in this document as moderate where an action would:

- Increase noise levels by 5 – 15 dBA above the federal range, thereby adversely affecting residential, commercial, or industrial properties and possibly creating some complaints.

Impacts would be classified in this document as low where an action would:

- Create short-term noise level disturbances or remain within 0 –5 dBA of federally suggested noise levels.

No impact would occur if there were no increase to the federal noise level.

4.10.2 Proposed Action

Generation Plant

Construction Noise

During construction of the Generation Plant and associated facilities, short-term noise sources would include heavy mobile equipment (e.g., bulldozers, backhoes, cranes, rock drills, heavy trucks, pumps, generators, compressors, loaders, and compactors). Construction equipment operation would vary considerably during the Project and during any given day. During the construction periods, the heavy mobile equipment is typically not run continuously and construction noise would generally occur only during the daytime hours (Sargent & Lundy 2002d).

The construction noise level predictions presented below are based on a conservative assumption that there would be five pieces of large mobile construction equipment operating simultaneously. Each individual piece of equipment typically generates noise levels up to 90 dBA at a distance of 50 feet from the equipment (DOT, 1995). Blasting is not expected, and most likely it would not be necessary to drive piles for any of the foundations (Sargent & Lundy, 2002d).

Construction activities typically occur during the daytime hours, but it is difficult to determine the length of time that the noise from a particular piece of equipment would persist during normal construction activities, since the noise is intermittent. Calculations indicate that the noise generated from five large pieces of construction equipment would be approximately 40 to 60 dBA at the noise sensitive receptor locations identified in Figure 3-7.

Near the end of the Project construction, it would be necessary to generate steam in the boiler and release it to the atmosphere to clean the steam piping. This operation is a one-time event and would be done during the day, one operation per day generally over a two-week period. A steam blow silencer could be used to reduce the steam discharge noise to about 85 dBA at 100 feet from the discharge, which would result in moderate noise levels at the receptors. Notices providing the schedule for these operations would be given to nearby residents and others in the community (Sargent & Lundy, 2002d).

Although the construction noise levels could be audible at the receptors and may be considered an annoyance during the various construction phases, the construction noise impacts are predicted to be low. Construction noise would normally only occur during the day and residents are typically less sensitive to noise during the day than they are at night.

Operation and Maintenance Noise

Once the twin Generation Plants are operational, dominant long-term noise sources could include exposed equipment, enclosed associated facility equipment, and the coal handling area. Table 4-26 lists the noise sources for the Generation Plant and associated facilities.

Table 4-26 Roundup Power Project Noise Sources

Exposed Generation Plant Equipment	Associated Facility/Coal Handling Equipment
Air-cooled condensing units	Coal pile bulldozers
Main transformers	Enclosed transfer tower
Induced-draft (ID) fans	Crushers in crusher house – enclosed
	Forced-draft (FD) fans
	Primary-air (PA) fans

Source: Bull Mountain Development Company, LLC., 2002a

Typical noise control measures for the Generation Plant, as previously mentioned, have been included in the noise level model. These measures are consistent with typical design practice for Generation Plants similar to the Proposed Action.

Lime would be delivered to the plant by bottom dump railroad cars. Generally, a main line locomotive would bring in the cars, and the empty cars would be removed in 10 to 15 car groups twice per month, or more cars would be removed less often. A small railroad car-moving tractor would be used to position several cars per day for unloading, five days per week (Sargent & Lundy, 2002d). The lime delivery operation would be audible at the receptors, but should not create any impact compared to operations associated with the plant.

Day Average (L_d) Generation Plant Noise Levels

The predicted noise levels at the receptors (Figure 3-7 in Chapter 3), due to the typical outdoor Generation Plant and associated facility (coal handling) equipment listed in Table 4-26, were calculated and estimated during the daytime and nighttime hours. For this analysis, it was assumed that all of the outdoor Generation Plant equipment would operate simultaneously and continuously 24-hours per day.

Table 4-27 lists an approximate analysis of day average (L_d) noise levels hand calculated and generated from the combination of only the Generation Plant and associated facility equipment at the nearby receptors. The L_d level is the 15-hour average noise level between 7:00 a.m. and 10:00 p.m., and should not be compared to the EPA L_{dn} recommendation, because the L_{dn} and L_d are two different metrics.

Table 4-27 Day Average Noise Levels Due to the Power Project

Receptor	Estimated Generation Plant L_d Noise Level Without Additional Noise Control Measures Installed (dBA)	Estimated Associated Facility L_d Noise Level (dBA)	Combined Noise Level With Additional Generation Plant Noise Control Measures Installed (dBA)¹
A	58	48	51
B	52	41	44
C	49	33	42
D	46	31	35
E	49	18	31

Source: Bull Mountain Development Company, LLC., 2002a.

¹ Combined L_d noise level were calculated assuming that the Generation Plant noise was continuous during the 15-hour period, with the associated facility mobile equipment operating for 3 hours.

Compared to the measured daytime ambient noise levels in the vicinity of the receptors, the combined day average noise level would exceed the measured ambient noise levels by approximately 18 dBA at Receptors A, with the additional noise control measures installed. The owners at this receptor received an offer to buy their property. They declined the offer but were made aware of the noise levels.

Night Average (L_n) Generation Plant Noise Levels

Table 4-28 lists the approximate night average (L_n) noise levels calculated and generated from only the Generation Plant equipment at the nearby receptors. The L_n level is the 9-hour average noise level between 10:00 p.m. and 7:00 a.m., and should not be compared to the EPA L_{dn} recommendation, because the L_{dn} and L_n are two different metrics.

Table 4-28 Night Average Noise Levels Due to the Power Project

Receptor	Estimated Generation Plant L_n Noise Level Without Additional Noise Control Measures Installed (dBA)	Estimated Generation Plant L_n Noise Level With Additional Noise Control Measures Installed (dBA)
A	58	48
B	52	39
C	49	42
D	46	33
E	49	31

Source: Bull Mountain Development Company, LLC., 2002a.

Compared to the measured nighttime ambient noise levels near the receptors the night average noise level due to the Project would exceed the existing ambient noise levels by approximately 12 dBA at the receptors, with the additional noise control measures installed.

Day-Night (L_{dn}) Generation Plant Noise Levels

The acoustical noise model was based on geometrical and acoustical data specifying the sources. The SoundPLAN prediction process scans the geometry from the receiver. The scanning or searching process is conducted with a search ray. For each source and receiver combination the SoundPLAN software determines the mitigation parameters based upon, spreading, meteorological effect, air absorption, ground effects, barrier effects (such as over vertical and around horizontal diffraction). The predicted L_{dn} noise levels were compared to the maximum L_{dn} value (55 dBA) recommended by the EPA for residences (EPA 1974) and the estimated existing L_{dn} values based on the measured levels (see Section 3.10.2). The calculated effects of the Mine and railroad operation were intermittent contributors to the overall noise directivity, and were eliminated from further consideration as concerns continual impacts. Table 4-29 summarizes the predicted L_{dn} noise levels

Table 4-29 Predicted Day-Night Noise Levels Due to the Power Project

Receptor	Estimated Ambient L_{dn} Before Construction of Mine and Railroad (dBA)	Estimated Ambient L_{dn} After Mine and Operations Begin (dBA) ¹	Predicted L_{dn} Due to Power Project Only Without Additional Noise Control Measures (dBA) ²	Predicted L_{dn} Due to Power Project Only With Additional Noise Control Measures (dBA) ²
A	35	44	74.1	55
B	35	45	70.5	51.5
C	35	40	67.7	47.2
D	35	41	64.7	46.5
E	35	37	68.7	46.9

Source: Based partially on information obtained in Supplemental Environmental Impact Statement Support Document,(Bull Mountain Development Company, LLC., 2002a)

¹ L_{dn} noise level = estimated L_{dn} before construction of the Mine and railroad (Section 3.10.3) plus the estimated L_{dn} due to the operation of the Mine and railroad (Table 3-15) (using logarithmic addition).

² L_{dn} calculated using the Concawe Model with Soundplan Software.

The predicted day-night noise levels (L_{dn}) at the receptors are primarily due to the Generation Plant equipment and operations, since they operate continuously. See Figure 4-1 for comparisons of noise levels depicted graphically as noise contours. With the additional noise control measures installed, L_{dn} values of 55 dBA as recommended by the EPA, or less, are predicted at all the receptors. Without additional noise control measures, the EPA guideline is predicted to be exceeded at all receptors. The modeling predicts that noise reductions must be implemented to

reduce noise from the stack at least 25.3 dBA, the Air Cooled Condensers at least 15 dBA, and from the transformers at least 10 dBA.

The EPA guideline of L_{dn} 55 dBA would not be exceeded at the receptors if the suggested noise control reduction measures were employed. As such, the noise impacts due to the Generation Plant would be low. However, if the described noise reduction measures were not installed, the noise impacts due to the Generation Plant are predicted to be high.

Steam Vent Equipment Noise

Steam from the boilers would need to be vented during the Generation Plant startup after construction, during restarting the plant after maintenance activities, and for emergency high-pressure safety releases. Although noise from the steam vents typically only lasts up to several minutes and occurs very infrequently (typically 1 to 2 times per year), the noise generated by the vents can be substantial. The noise levels generated during a single steam vent occurrence at the nearby receptors would be approximately 80 dBA. Since the potential disturbance is very infrequent and brief, the impact of the steam vent noise is predicted to be moderate. Steam vents were not included in the previously discussed calculations of L_{dn} values. To limit the noise produced by the high-pressure boiler steam vents, discharge mufflers would need to be installed at the vent openings, if action were to be continual. The steam vent relief valves were not considered in calculations for the noise contour modeling shown in Figure 4-1 because of the infrequent occurrence of this operation

In-Mine Waste Disposal

In-mine waste disposal for future expansion of the landfill operation would not be an immediate concern for plant operations. There were neither predictions nor impacts studied or associated with this ash landfill disposal method. This option is not expected to be in service for at least 10 years and would undergo further assessment at that time and further permitting and design decisions would be undertaken. It is expected that the ash would be trucked to the Mine on rubber tired vehicles over a Mine haul road. This road would be designed to minimize impacts from noise and would be farther from the sensitive receptors thus reducing any additional audible impacts. It is not foreseen to be a significant contributor of noise over the life of the Generation Plant.

The noise impacts at the receptors due to the Generation Plant are summarized in Table 4-30.

Table 4-30 Summary of Impacts on Noise Levels from Construction and Operation of the Project

Activity	Potential Impact	Impact Level
Construction Activities	Temporary and intermittent annoyance and stress due to increased noise levels at receptors during the construction period during daylight hours.	Low
Typical Generation Plant and Associated Facility Operations (with additional noise control measures as necessary)	Potential long-term annoyance, sleep disturbance, and stress at the receptors due to noise generated by the operations.	Low

Activity	Potential Impact	Impact Level
High-pressure steam vent	Temporary and infrequent annoyance, speech interference, stress, and possible sleep disturbance due to an intermittent and brief increase in noise levels at receptors.	Moderate

Source: : Bull Mountain Development Company, LLC., 2002a.

Since the predicted noise levels of the Generation Plant would not exceed the EPA recommendation of L_{dn} 55 dBA (even though the predicted noise levels exceed the existing nighttime ambient noise levels by more than 10 dBA), the noise impacts at the receptors have been categorized as “low.”

Because the range of reactions of a typical persons to a given noise environment fluctuates, there is a possibility that some people represented by these receptors may subjectively consider the noise levels generated by the Project to be an annoyance. Criteria 1 impacts from the State Highway Administration (SHA) are intended to indicate potential noise impacts and the EPA guideline is commonly accepted as a target to prevent impacts at residences due to noise.

Since the perception of noise by individuals can vary significantly, an estimated probable average was referred to for criteria that indicates potential for complaints. Previous surveys from the past forty years used a factor to assess community responses around generation plants. This factor is referred to as the normalized outdoor day-night sound level. Based on these case histories, community responses were quite negative when noise levels reached 80 dBA and were slightly negative when noise levels reached 62 dBA (Elliot et al., 1998). Since the predicted noise levels for the Project remain below the EPA guidelines of L_{dn} 55 dBA, we would not expect a community response; however, noise would be noticeable.

The predicted noise levels have been modeled according to a typical coal fired generation plant with and without additional noise control measures included. Since the Generation Plant and its associated facilities have not yet been designed in detail, these preliminary noise level estimates may change, as the design progresses and specific equipment selections are made.

Figure 4-1 Noise Contours

161kV Transmission System

The 161kV Transmission System includes double circuit 161kV transmission lines and a parallel single circuit 161kV line to be installed on a wooden H-frame structure located adjacent to the railroad right-of-way (Figure 2-7 and Figure 2-11). The three proposed transmission circuits would interconnect with the Broadview Substation and follow the permitted railroad right-of-way. The Transmission System could generate a small amount of audible noise, typically during an abnormally foul weather event, such as fog or heavy torrential rain, noticeable only if you were underneath in the corridor. The predicted maximum audible noise levels, based upon similar designed transmission systems utilizing single conductors, has been calculated according to BPA references at the 43 dBA level at the right-of-way, measured from the center line. The lines are not expected to be audible nor approach the limit of the measured background noise levels. They would not be audible at any of the closest noise sensitive receptors, which were estimated to be further than 300 feet from the right-of-way. They would not be included in any cumulative nor predicted noise calculations. As such, no noise impact is expected for the Transmission System.

4.10.3 Action Alternatives

Landfill Alternative

It is expected that the ash would be transported by truck to the landfill as part of this alternative to the Proposed Action. This would require vehicular transport and would be located on the north side of the facility, thereby minimizing noise impacts to sensitive receptors. This alternative would allow for waste storage to be further from the sensitive receptors (as compared to Mine storage for the Proposed Action) thus minimizing any additional audible impacts. It is not foreseen to be a significant contributor of noise over the life of the Generation Plant. This action alternative could be a more environmentally noise friendly option than the Proposed Action (disposal to the Mine).

230kV Transmission System

The alternative to include a 230kV Transmission System would be similar to the Proposed Action, utilizing an H-frame design with parallel single circuit 230kV transmission lines (refer to Figure 2-7 for details) located adjacent to the railroad right-of-way. The 230kV Transmission System would interconnect with the Broadview Substation and follow the permitted railroad right-of-way. The Transmission System could generate a small amount of audible noise, typically during foul weather, such as fog or rain. The predicted maximum audible noise levels, based upon similar designed systems utilizing single conductors, has been calculated according to BPA's Corona and Field Effects program to be in the 58 dBA level at the right-of-way, measured from the center line. The lines are not expected to be audible nor approach the limit of the measured background noise levels at any of the closest noise sensitive receptors, which were verified to be further than 300 feet from the right-of-way. They were not included in any cumulative or predicted noise calculations. No noise impacts are expected from the 230kV Transmission System. As such, noise impacts are expected to be the same as impacts identified for the Proposed Action.

4.10.4 Mitigation Measures

There are no existing enforceable mitigation measures that can be acted upon by any agency. The regulatory agency does not have the authority to create mitigation measures that they can enforce, without the direct consent of the Project proponent. The EPA and the Department of Transportation provide suggested noise levels that minimize impact to the public.

To ensure that the Generation Plant noise is not excessive, careful evaluation and selection of typical low noise design options, equipment specifications, building and wall designs, and enclosure constructions should be made during the design process. Typical noise control measures, such as FD fan intake louver design and duct silencers, as well as PA fan location and equipment abatement enclosures, could be installed initially. The plant design could also include specifications calling out low noise options for cooling tower and transformer equipment. The design could also include provisions, such as longer-than-normal ID fan discharge ductwork and increased fan capacity, to accommodate silencers in the discharge stacks, but these silencers would not be installed initially (Sargent & Lundy 2002a). The Project could be constructed, and, if measured noise levels exceed L_{dn} 55 dBA at the sensitive receptors, the additional noise control measures then could be installed as necessary to avoid adverse impacts on the sensitive receptors.

4.10.5 No-Action Alternative

Under the No-Action alternative, the Project and associated facilities would not be built. There would not be any alteration to facilities that generated noise; therefore, no additional noise impact would occur.

4.11 Land Use

This section describes the types of impacts that would potentially occur to land use resources from construction, operation, and maintenance of the proposed Project and alternatives. Mitigation measures used to reduce impacts to land use resources are also discussed.

4.11.1 Methods

Information was obtained from the Supplemental EIS Support Document (Bull Mountain Development Co., LLC, 2002a) for background information on the land use impact assessment. The Bull Mountains Mine FEIS (Montana Dept. of State Lands, 1992) and the Railroad Spur Checklist EA (DNRC, Trust Land Management Division, 2002) were also used as references for this section.

Impact Levels

Impacts would be classified in this document as high where an action would:

- Convert active and productive farmlands to a non-farm land use
- Create areas of non-inhabitable land where residential uses already exist or are permitted
- Prevent the use of the land according to existing or approved land management plans

Impacts would be classified in this document as moderate where an action would:

- Adversely affect existing farmlands by limiting farm production or the types of farm uses
- Adversely affect residential, commercial, or industrial properties by eliminating or limiting the potential for residential development to occur
- Adversely affect commercial or industrial properties by introducing additional or new inconveniences to business operations
- Alter the use of the land according to existing or approved land management plans

Impacts would be classified in this document as low where an action would:

- Create short-term disturbances such as minor crop damage during construction or restrict improvements to previously affected areas (e.g. existing structure locations).
- Create short-term disturbances, but still allow the continued use of the land according to existing or approved land management plans.

No impact would occur when land uses would be able to continue as currently exist.

4.11.2 Proposed Action

Generation Plant

Construction of the Generation Plant would convert the immediate Generation Plant site to heavy industrial use. Currently, the entire site (Section 15, Township 6 North, Range 26 East) is undeveloped land potentially available for livestock grazing and other agricultural uses. During Project construction, the entire site would be unavailable for grazing or other uses. Upon completion of construction, the permanently disturbed area (conservatively estimated to be 208 acres) would be unavailable for uses other than power generation. Undeveloped parts of Section 15 outside the plant fence may be made available for livestock grazing, but these plans have not been finalized. Even if all 640 acres of Section 15 were permanently removed from agricultural use, this would represent a loss of less than 0.1% of the agricultural land in Mussellshell County. Industrial land use, on the other hand, is limited in Mussellshell County, currently representing less than 0.1% of the total land in the county. Therefore, conversion to power generation would be a beneficial land use change that would add significant diversity to the county's economic base.

Recreational land use near the Generation Plant site includes dispersed outdoor activities such as hunting and horseback riding. Dispersed recreation use currently occurring within the Generation Plant site would be displaced during construction and operation, resulting in a long-term impact. Because numerous opportunities for dispersed recreation are present on surrounding private and public lands, impacts would be low.

Construction of the Generation Plant is expected to take approximately 4 years. During this time, the site would be a large construction area. Noise, dust, onsite machinery movement, and human activity would be noticeable from the residential, religious, and agricultural land uses located near the Project site. Construction also would generate considerable traffic to and from the site. Substantial increases in traffic, noise, and dust have the potential to temporarily affect the

emotional setting or character of nearby areas. Residential and religious land uses would likely be most susceptible to impacts of this type. However, since construction would be restricted to daylight hours and would not continuously involve the same activities, impacts would be intermittent. Overall, land use impacts due to construction activities and vehicle movement would be short-term and low.

Generation Plant waste disposal would involve the conveyance of ash from the Generation Plant site east to a location within an adjacent Mine. Depending on the conveyance method, short-term impacts could result from noise and dust associated with construction of a haul road or other means of transport (e.g., conveyor, slurry pipeline). Long-term impacts could include noise, dust, and the conversion of land potentially available for livestock grazing, other agricultural uses and dispersed recreation activities to heavy industrial use. Based upon the same reasons stated above, impacts would be low.

Because the Generation Plant is within easy commuting distance of the City of Billings, in-migration of workers and their families to the local area would likely not be extensive. However, some non-local workers may choose to live near the construction site in their own campers or trailers. Local business people might respond to the increased demand for camper/trailer spaces by developing trailer courts and camper parks. Development of such facilities could be a permanent land use change. The new facilities could be established at any suitable locations within a reasonable commuting distance of the Project site, but it is likely that they would be located in the subdivided areas near the site. It is possible that a convenience store or other small commercial facility also could be established in the subdivided areas. Since most of the subdivided parcels near the site currently are undeveloped and the land is idle, such developments would represent a beneficial land use impact.

The long-term economic and population effects of the Generation Plant's operation would likely stimulate some land use changes in the City of Roundup and other parts of Musselshell County. The Project's direct and induced population and economic effects would generate demand for new and improved housing, business, and government products and services. Private and public sector responses to changes in demand for products and services would cause some changes to area land uses, including increased investment in housing and businesses. These changes generally would be considered beneficial land use impacts.

Currently there are no land use plans or zoning classifications applicable to the Generation Plant site. The proposed Generation Plant is not inconsistent with the Musselshell County Comprehensive Plan.

The Project Proponent would comply with Federal Aviation Administration (FAA) requirements regarding structure marking and lighting as well as other FAA requirements regarding public safety.

161kV Transmission System

Development of the proposed Transmission System would add a double circuit 161kV transmission line and a parallel single circuit 161kV transmission line to the current land uses within the 225-foot right-of-way.

Placement of transmission structures, access roads upgrades and construction, and conductor tensioning sites have the potential to impact residences, non-irrigated cropland, livestock grazing, CRP land, and dispersed recreation activities.

Short-term (construction) and long-term (maintenance) impacts could result from increased traffic, noise, dust, and restricted, blocked, or detoured access to residences and dispersed outdoor recreation activities such as hunting, horseback riding, and hiking. These impacts would primarily occur from the use of heavy machinery/equipment. Overall, disturbances to residences and dispersed outdoor recreation activities during construction and maintenance of the Transmission System would be low, due to the temporary nature of the construction activities and intermittent and temporary nature of the maintenance activities at any one location along the right-of-way.

Construction activities would also involve the crossing of various roadways. Agreements or permits to do so are available from the administering agency having jurisdiction over such road rights-of-way. Potential short-term direct impacts to roadways could occur from the crossing of the Project component. Generally, the potential impacts of these crossings are avoided by spanning the travel route and using traffic and safety controls during construction (e.g., flag-persons, warning signs, guard structures) and therefore are expected to be low.

Short-term (construction) impacts on non-irrigated cropland, livestock grazing, and CRP land could occur. Impacts to non-irrigated cropland could include disruption of farming practices (e.g., preclusion or interference with planting, maintaining, or harvesting) and seasonal loss of crops during construction. Impacts to livestock grazing could result from the disturbance, disruption, and/or alteration of this use. There is also a potential for damage to rangeland improvements, such as fences and gates. In addition, human activity, movement of vehicles/equipment, and noise could disturb grazing livestock and drive them away from livestock water sources near the construction area. Impacts to CRP land could result from construction disturbance. Disturbances from construction activities and temporary occupancy of the land within the 225-foot right-of-way could result in a temporary loss of non-irrigated cropland, grazing land, and CRP land through the removal of vegetation. This temporary loss of the use would result from construction disturbance at transmission structure sites (including laydown areas), staging areas, and in areas where new temporary access is required. Construction activities and temporary occupancy of the land could also result in a temporary loss of the use outside the right-of-way as a result of staging area construction.

Long-term (operation and maintenance) impacts on non-irrigated cropland, livestock grazing, and CRP land could occur. Impacts to non-irrigated cropland could include (1) removal of non-irrigated cropland from production at transmission structure sites and new access road sites; (2) reduction in crop yields around transmission structures because of soil compaction during construction and increased difficulties with weed and pest control; (3) increased time required for farming operations; (4) disruption of agricultural aircraft operations; and (5) economic losses. Impacts to livestock grazing could result from those grazing areas permanently displaced by transmission structure sites and new access road sites. Impacts to CRP land could include (1) removal of CRP land at transmission structure sites and new access road sites; (2) increased difficulties with weed and pest control; (3) disruption of aircraft operations involving weed and pest control application; and (4) economic losses.

Transmission System maintenance activities could cause impacts through land use interference. Depending on the season and timing of the maintenance activities, vehicular and foot traffic, human activity, and use of machinery/equipment could interfere with planting, maintaining, or harvesting crops. This same type of disturbance could disturb grazing animals, drive them away from the right-of-way, and disturb CRP land. This could result in a temporary, intermittent loss of non-irrigated cropland, grazing land, and CRP land over an area larger than the right-of-way.

Short-term and long-term impacts on non-irrigated cropland, livestock grazing/grazing land, and CRP land would be low because of the minimal extent of disturbance on these land uses as a result of Project construction, operation and maintenance. The area disturbed by construction would be minimal, and following rehabilitation, the only areas removed from use for the life of the Project would be the small areas at the transmission structure footings and/guy anchors and new access roads that would remain permanently. The non-irrigated cropland no longer available for farm use would represent a small portion of cropland when compared to 2000 non-irrigated harvested crop (all) acreage in Musselshell County (38,600 acres) and Yellowstone County (111,600 acres). The remainder of the non-irrigated cropland within the right-of-way would be available for non-irrigated cropland. Non-irrigated cropland would be able to continue around the transmission structures, and underneath the transmission line. Where non-irrigated cropland would be crossed, impacts would be minimized through spanning of cultivated fields, where feasible. The remainder of the rangeland within the right-of-way would be available for grazing. Livestock grazing would be able to continue around the transmission structures, underneath the transmission lines, and over necessary access roads. The removal of CRP land would represent a small portion of CRP land when compared to current (October 31, 2002) total CRP acreage in Musselshell County (40,651 acres) and Yellowstone County (55,868.4 acres). The remainder of CRP land would be able to continue around the transmission structures, and underneath the transmission line. Where CRP land would be crossed, impacts would be minimized through spanning of fields, where feasible.

Maintenance activities would be intermittent, temporary, and generally occur at any one location or point along the right-of-way.

In addition, indirect long-term impacts from increased access and changes in access patterns may occur. Increased vehicle or foot access could increase with new roads and indirectly result in increased littering or dumping of trash, tree cutting, illegal hunting, and other unauthorized activities on private and public lands.

Currently there are no land use plans or zoning classifications applicable to the proposed Transmission System. The proposed Transmission System is not inconsistent with the Musselshell County Comprehensive Plan and Yellowstone County Comprehensive Plan.

The Project Proponent would comply with Federal Aviation Administration (FAA) requirements regarding structure marking and lighting as well as other FAA requirements regarding public safety.

Summary of Impacts from the Proposed Action

Table 4-31 provides a summary of impacts to land use from the Proposed Action.

Table 4-31 Summary of Impacts on Land Use from Construction, Operation, and Maintenance of the Proposed Roundup Power Project

Potential Impact	Impact Type	Impact Level
Conversion of Generation Plant site to industrial use	Direct, Long-term, Beneficial	Low
Displacement of dispersed outdoor recreation activities by construction and operation of the Generation Plant site	Direct, Long-term	Low
Increased traffic, noise and dust due to Generation Plant construction	Direct, Short-term	Low
Potential induced commercial and residential development due to Generation Plant operation	Direct, Long-term, Beneficial	Low
Disturbance of residences and dispersed outdoor recreation activities due to Transmission System construction and maintenance	Direct, Short-term and Long-term (maintenance)	Low
Disruption of farming practices and seasonal loss of crops during Transmission System construction	Direct, Short-term	Low
Removal of non-irrigated cropland; Interference with the use of non-irrigated cropland during Transmission System operation	Direct, Long-term	Low
Disruption or alteration to livestock grazing during Transmission System construction and maintenance	Direct, Short-term and Long-term (maintenance activities)	Low
Removal of grazing land during Transmission System operation	Direct, Long-term	Low
Disturbance of CRP land during Transmission System construction	Direct, Short-term	Low
Removal of CRP land during Transmission System operation	Direct, Long-term	Low
Increased access	Indirect, Long-term	Low

4.11.3 Action Alternatives

Landfill Alternative

Impacts would be the same as those presented for the Generation Plant. Impacts to the landfill expansion are not expected to take effect for ten years beyond the impacts that the Generation Plant would impose. This is because the landfill within the existing Generation Plant design is

expected to take ten years to reach capacity. Impacts to land use resulting from construction and operation of the landfill expansion would therefore be low.

230kV Transmission System

Impacts for the most part would be the same as the 161kV Transmission System with the exception of the 230kV Transmission System utilizing a 300-foot right-of-way, fewer access roads, and fewer transmission structures. As a result, ground disturbance would be less than that of the 161kV Transmission System.

4.11.4 Mitigation Measures

The Project Proponent would comply with Federal Aviation Administration (FAA) requirements regarding structure marking and lighting as well as other FAA requirements regarding public safety.

The regulatory agency does not have the authority to create mitigation measures that they can enforce, without the direct consent of the Project proponent. Potential mitigation measures to minimize impacts to land use resources are listed in Chapter 2, Section 2.2.5 in the Land Use and Safety subsection. These measures mitigate impacts from the possible damage or alteration to existing structures (fences, gates, etc.) that could occur during construction activities.

4.11.5 No-Action Alternative

Under the No-Action Alternative, existing land uses on and near the Project site would continue. These land uses most likely remain largely agricultural and rural. Existing dispersed recreation activities would continue, subject to landowner permission. Residential development would continue in the subdivided areas near the Project site, but without the economic stimulation provided by the Project. Little or no commercial development would likely occur near the Project site.

4.12 Socioeconomics

4.12.1 Methods

This section discusses the socioeconomic impacts expected to result from construction and operation of the Project. The Mine is a separate project, which is considered an existing action for purposes of this report. However, the Mine is not currently operating and has not operated for several years, so the socioeconomic impacts of the Mine are not reflected in the current socioeconomic conditions of the Study Area. Therefore, this section discusses the socioeconomic impacts of the Mine where necessary to put the Generation Plant impacts into proper perspective.

Construction and operation of the Project entail deploying manpower and equipment, which impose to one or another degree on the residents and communities in the vicinity of the Project in the form of demands for housing, commerce, public services, and other resources. For some residents, the demands are beneficial sources of income and employment, while for others the influx of strangers can be an imposition and a burden.

The assessment of socioeconomic impacts is organized in the following manner. The main variables of socioeconomic activity—population and housing, employment, personal income, taxes, public services, and so forth—are discussed sequentially, with the proposed alternative compared to the no-action alternative.

4.12.2 Population and Housing

The population and housing impacts of the alternatives are presented below.

Proposed Action and Action Alternatives

All aspects of the Project would noticeably affect housing in Musselshell County, and rental housing in Yellowstone County may be affected during the construction phase.

The projected population and housing impacts of the Project were derived using the same overall approach reported in the Supplemental EIS Support Document (Bull Mountain Development Co., LLC, 2002a) along with workforce projections supplied by the Project proponent. However, a number of estimating parameters were revised using more current information, such as that available from the 2000 Census of Population. The employment and labor income multipliers are derived from the IMPLAN impact analysis system, which is used by several Montana state agencies. The IMPLAN analysis system provides industry employment and labor income multipliers for each county. Table 4-32 provides the projection parameters.

Table 4-32 Economic Projection Parameters

Parameter	Projections
Multipliers	Employment multipliers: Mine jobs = .97 Generation Plant jobs = .64 Construction jobs = .52 Labor income multipliers: Mine labor income = .41 Generation Plant labor income=.15 Construction labor income=.33
Local hire ratio	Mine jobs 60% Generation Plant jobs 60% Construction jobs 40% Secondary jobs 70%
Population per job	Mine and Generation Plant jobs 3.0 Construction and secondary jobs 2.0
Persons 0 to 17 years old	20.7 percent of population
Grade distribution of in-migrating children	K-8 45% High school 19% Not enrolled in school 36%

Parameter	Projections
Residence of workers	Mine and Generation Plant Musselshell County 60% Yellowstone County 40%
	Construction workers Yellowstone County 75% Musselshell County 25%
	Secondary workers Musselshell County 90% Yellowstone County 10%

As shown in Table 4-33, the total population in both Musselshell and Yellowstone counties associated directly and indirectly with the Project (excluding the Mine) is projected to rise from 167 persons in year 1 to a peak of 3,722 persons in year 3. The long-run population increase would be 642 persons, which would occur in year 5 and thereafter. The peak population in Musselshell County would be about 1,814 persons in year 3, about 44 percent more than the 2000 population. The long-run population associated with the Project in Musselshell County would be about 443 persons, or about 11 percent more than the 2000 figure. These figures include both persons directly involved in construction and operation of the Project as well as people associated with secondary activities stimulated by the multiplier effects of the Project.

Although the Mine is considered an existing action, it is not currently in operation. The additional persons directly and indirectly associated with the Mine need to be considered in evaluating the overall impacts. As shown in table 4-34, the additional population in Musselshell and Yellowstone counties associated with the Mine would rise from 222 persons in year 1 to about 1,571 persons in year 3 and thereafter. The Musselshell County population associated with the Mine would rise from 159 persons in year 1 to about 1,127 persons in year 3. The additional persons associated with the Mine would represent about 27 percent of the 2000 population in Musselshell County.

There were a total of 1,878 households in Musselshell County in 2000, and only 98 owner occupied units and 36 rental units were vacant. Therefore, the population forecasts presented in Tables 4-33 and 4-34 even with a sizable margin of error, imply a need for significant additional local housing. There are a sizable number of seasonal, recreational, and otherwise unoccupied housing units, but their suitability for year-round use, even for a short period, is unknown.

Table 4-33 Projected Direct and Secondary Employment, Labor Income, and Population Associated with the Roundup Power Project Musselshell and Yellowstone Counties

Category	Year 1	Year 2	Year 3	Year 4	Year 5	Year 6	Year 7	Year 8	Year 9	Year 10	Year 30
Employment											

Category	Year 1	Year 2	Year 3	Year 4	Year 5	Year 6	Year 7	Year 8	Year 9	Year 10	Year 30
Generation Plant Operations			60	120	150	150	150	150	150	150	150
Construction	55	755	1140	292							
Total Primary	55	755	1200	413	150	150	150	150	150	150	150
Secondary	29	392	631	228	97	97	97	97	97	97	97
TOTAL EMPLOYMENT	84	1147	1831	641	247	247	247	247	247	247	247
Labor Income (millions 2001\$)											
Generation Plant Operations			3.30	6.60	8.25	8.25	8.25	8.25	8.25	8.25	8.25
Construction	2.64	36.24	54.72	14.00							
Total Primary	2.64	36.24	58.02	20.6	8.25	8.25	8.25	8.25	8.25	8.25	8.25
Secondary	0.87	11.96	18.56	5.41	1.03	1.03	1.03	1.03	1.03	1.03	1.03
TOTAL LABOR INCOME	3.51	48.2	76.58	26	9.28	9.28	9.28	9.28	9.28	9.28	9.28
Population											
Musselshell County	79	1084	1814	773	443	443	443	443	443	443	443
Yellowstone County	88	1211	1908	628	199	199	199	199	199	199	199
TOTAL POPULATION	167	2295	3722	1401	642	642	642	642	642	642	642

Source: Bull Mountain Development Company, LLC., 2002a.

Table 4-34 Projected Direct and Secondary Employment, Labor Income and Population Associated with the Bull Mountains Coal Mine Project Musselshell and Yellowstone Counties

Category	Year 1	Year 2	Year 3	Year 4	Year 5	Year 6	Year 7	Year 8	Year 9	Year 10	Year 30
Employment											
Mine	45	198	318	318	318	318	318	318	318	318	318
Secondary	44	192	308	308	308	308	308	308	308	308	308
TOTAL EMPLOYMENT	89	390	626	626	626	626	626	626	626	626	626

Labor Income (millions 2001\$)											
Mine	2.45	9.93	15.82	15.82	15.82	15.82	15.82	15.82	15.82	15.82	15.82
Secondary	1.01	4.07	6.69	6.69	6.69	6.69	6.69	6.69	6.69	6.69	6.69
TOTAL LABOR INCOME	3.48	14.06	22.51	22.51	22.51	22.51	22.51	22.51	22.51	22.51	22.51
Population											
Musselshell County	159	702	1127	1127	1127	1127	1127	1127	1127	1127	1127
Yellowstone County	63	276	443	443	443	443	443	443	443	443	443
TOTAL POPULATION	222	978	1571	1571	1571	1571	1571	1571	1571	1571	1571

Source: Bull Mountain Development Company, LLC, 2002a.

Table 4-35 shows the combined employment and population impacts associated with the Project and the Mine, assuming that development of both projects begins in the same year. Cumulatively, the two operations would directly add nearly 5,300 persons to the two-county area population during the peak construction Year #3, while over the longer term; the incremental Project-related population would number about 2,200 persons.

Table 4-35 Projected Direct and Secondary Employment, Labor Income and Population Associated with the Bull Mountains Coal Mine and Roundup Power Project Together Musselshell and Yellowstone Counties

Category	Year 1	Year 2	Year 3	Year 4	Year 5	Year 6	Year 7	Year 8	Year 9	Year 10	Year 30
Employment											
Mine	45	198	318	318	318	318	318	318	318	318	318
Generation Plant			60	120	150	150	150	150	150	150	150
Construction	55	755	1140	292							
Total Primary	100	953	1518	730	468	468	468	468	468	468	468
Secondary	73	584	939	537	405	405	405	405	405	405	405
TOTAL EMPLOYMENT	173	1537	2457	1267	873	873	873	873	873	873	873
Labor Income (millions 2001\$)											
Mine	2.45	9.93	15.82	15.82	15.82	15.82	15.82	15.82	15.82	15.82	15.82

Generation Plant		3.30	6.60	8.25	8.25	8.25	8.25	8.25	8.25	8.25	8.25
Construction	2.64	36.24	54.72	14.00							
Total Primary	5.09	46.17	73.84	36.42	24.07	24.07	24.07	24.07	24.07	24.07	24.07
Secondary	1.88	16.03	25.25	12.10	7.72	7.72	7.72	7.72	7.72	7.72	7.72
TOTAL LABOR INCOME	6.97	62.20	99.09	48.54	31.8	31.8	31.79	31.79	31.79	31.8	31.79
Population											
Musselshell County	238	1785	2941	1901	1570	1570	1570	1570	1570	1570	1570
Yellowstone County	151	1487	2351	1071	642	642	642	642	642	642	642
TOTAL POPULATION	389	3272	5293	2972	2212	2212	2212	2212	2212	2212	2212

Source: Bull Mountain Development Company, LLC, 2002a.

¹Besides the Generation Plant and Mine personnel, whose numbers are projected to peak at 1,518 workers in year 3, an additional maximum of 44 workers would be involved in construction of the Transmission System from the Generation Plant to the Broadview Substation. These workers would not represent a noticeable additional burden on the Roundup area local socioeconomic setting, mainly because they would largely originate from, or would seek temporary accommodation in, the Billings area (which is the principal labor market in the region as well as offering more amenities to transmission line special trade workers recruited from elsewhere).

Using the statewide household size of 2.45 persons, there would be a need for approximately 740 housing units in Musselshell County to serve the population increase expected during the peak of Generation Plant construction in year 3. During the operations phase in year 5 and thereafter, there would be a need for about 181 housing units to serve the population increase in Musselshell County. In addition, the Mine would create the need for about 65 housing units in Musselshell County during year 1, and this would rise to 460 housing units during year 4 and thereafter. Therefore, the Generation Plant and Mine together would create a peak need in Musselshell County for about 1,200 housing units, and a long-term need for about 641 housing units.

In Yellowstone County, the Project would create a peak need of about 778 housing units in year 3 and approximately 81 housing units in year 5 and thereafter. The Mine would create a need for about 26 housing units in year 1, which then rises to a need of 181 housing units in year 4 and thereafter. Altogether, the Generation Plant and Mine would create a peak need in Yellowstone County of about 959 housing units in year 3, and a long-run need of approximately 262 housing units.

As reported in Chapter 3, there was a total of 2,317 housing units in Musselshell County in 2000, and only 98 owner occupied units were vacant and 36 rental units were vacant. Therefore, the population forecasts presented in Tables 4-33 through 4-35, even with a sizable margin of error, implies a need for significant additional local housing. There are a sizable number of seasonal, recreational, and otherwise unoccupied housing units, but their suitability for year-round use, even for a short period, is unknown.

A lack of data makes it difficult to predict whether workers would choose to locate in Musselshell County or Yellowstone County. People try to minimize time spent in travel to and from work, which suggests that most non-local personnel would endeavor to find accommodations in the vicinity of the job site. Offsetting that propensity, however, is the availability of housing and other amenities, which are very limited in the Roundup area, as well as the length of time that a visiting worker would need to relocate. Many construction workers, for example, are “weekend commuters,” spending the workweek near the site sharing space in a motor home or RV or motel room, but returning home for the weekend. Car-pooling construction workers often drive several hundred miles over the weekend in order to see their families.

The peak construction year housing needs may require temporary facilities. Obviously, the need of 1,200 housing units in Musselshell County would require some short-term solutions. Possibilities include using mobile homes or trailers, and the creation of temporary RV parks and other facilities. Much of the property near the Generation Plant site has been subdivided, and some of this property may be used for the development of trailer courts or RV parks.

In Yellowstone County, the year 3 housing requirement for 959 units compares with the 867 vacant rental units reported in Yellowstone County during 2000, with an additional 3,609 licensed hotel/motel rooms and 337 RV spots available for transient housing. Therefore, the need for rental housing Yellowstone County may exceed available units during the period of peak construction. Creation of temporary housing using mobile homes and the creation of temporary RV facilities could facilitate short term lodging.

Increased demand for temporary and permanent housing would be beneficial for those with rental property, those with permanent home sites, those desiring to sell existing housing units, and those in the home and apartment construction business. Of particular interest to local developers would be the permanent operating personnel, which would require long-term housing. On the other hand, people attempting to buy or rent housing may face increased costs and increased competition for existing units in the first couple of years during the buildup of the Generation Plant and Mine workforces.

No-Action Alternative

Under the No-Action alternative, the Project would not be permitted and constructed. There would be no need for the additional housing units associated with the Project permanent work force, although the need would still exist for the Mine. Residential land prices and prices of existing homes would not be affected by increased demand. The rental and temporary housing market in Yellowstone County would not be affected during the peak years of Project construction. There likely would not be a shortage of rental and temporary housing.

4.12.3 Employment

The employment impacts of the alternatives are presented below.

Proposed Action and Action Alternatives

The Mine is considered an existing action, but the employment impacts of the Mine have not yet occurred. The Mine impacts were calculated and included here for informational purposes. The

Mine impact estimates were derived with the revised parameters and projection methods used for the Generation Plant impacts.

The direct and indirect employment impacts of the Generation Plant were presented above in Table 4-33 while the corresponding impacts of the construction and operation phases of the Mine were shown in Table 4-34. The combined impacts of both projects together were presented in Table 4-35.

All Mine, Generation Plant, and secondary employment and labor income are assigned to Musselshell County regardless of where the workers live because employment and labor income are measured using a “where earned or worked” basis. There may be a small number of new secondary jobs and labor income created in Yellowstone County, but the projection method used here does not provide these estimates. This requires a respecification of the IMPLAN model for a different spatial area, and then re-solving the simultaneous equation system.

According to information provided by the Project sponsors, Generation Plant employment begins with 55 construction workers in year 1, as shown in Table 4-33. Construction employment rises to a peak of 1,140 in year 3. All construction activity is completed by year 5. Generation Plant operations start with 60 workers in year 3, and full operation with 150 workers is reached in year 5. Estimated secondary employment rises from 29 workers in year 1 to a peak of 631 workers in year 3, and then declines to its long-run level of 97 workers in year 5. At the peak in year 3, Generation Plant operations and construction employment would total approximately 1,831 workers, roughly doubling the existing total employment in Musselshell County (see Chapter 3). The long-run total primary and secondary employment associated with the Generation Plant is about 247 workers, or roughly ten percent of existing employment in Musselshell County.

As reported in Table 4-34, Mine employment begins with 45 workers in year 1 (mostly startup activities), rises to 198 workers in year 2, and with the Mine reaching full production in year 3 with 318 workers in year 3, continues at that level thereafter. Estimated secondary employment rises from 44 workers in year 1 to the long-run operations level of 318 workers in year 3 and thereafter. Beginning in year 3, long-run total employment associated with the Mine would be approximately 626 workers, representing about a one-third of the existing level of employment in Musselshell County (see Chapter 3).

Labor income associated with the construction and operation of the Project would rise from \$3.5 million (2001 dollars) in year 1 to a peak of \$75.6 million (2001 dollars) in year 3, and then decrease to its long-run level of about \$9.3 million (2001 dollars) in year 5 and thereafter. As noted in Chapter 3, total labor income in Musselshell County was about \$31.0 million (2001 dollars) in 1999. At its peak in year 3, construction, operations, and secondary labor income would be about 250 percent of the current labor income in Musselshell County.

The labor income earned by coal miners and secondary workers would rise from about \$3.5 million (2001 dollars) in year 1 to approximately \$22.5 million in year 3 and thereafter. The long-run level of primary and secondary coalmine labor income would be approximately two-thirds of existing labor income in Musselshell County.

The average labor income per worker (both primary and secondary) associated with the Mine and Generation Plant construction and operation would be about \$40,800 (2001 dollars) in the peak year 3. The corresponding figure would be approximately \$36,400 (2001 dollars) in year 5 and thereafter. Average labor income in Musselshell County was about \$15,200 (2001 dollars) in

1999 (see Section 3.12.3). Therefore, the Project and Mine would significantly increase average earnings per worker in Musselshell County and would likely reverse the downward trend in relative per capita income (as reported in Chapter 3). If existing residents would fill many of the new positions, they would benefit from the higher rates of pay.

In summary, the proposed Project would have tangible beneficial economic impacts on Musselshell County. During the construction peak, employment would more than double and labor income would triple. When the Projects reach their long-run staffing levels, Musselshell County's labor income would increase by about one-third and employment would rise by 12 to 15 percent. The average earnings of the new jobs are well above those of existing jobs, thereby reversing the downward trend in relative per capita income in Musselshell County. The total population associated with the Project would reach a peak of 3,722 persons during the third year of the construction phase, and then stabilize back at about 443 persons during the operations phase. The increased job opportunities and higher wages would benefit those looking for employment and those seeking to increase their wages and income. The higher wages may also entice some persons to return to the labor force. The overall tightness of the local labor market may force existing employers to raise their wages in order to retain employees, however. The increased population, workforce, and incomes would improve the opportunities for local merchants serving these markets. Higher wages paid for existing jobs would increase costs to employers and possibly raise prices to ultimate customers.

No-Action Alternative

Under the No-Action alternative, employment, per capita income, and population would increase as described in the baseline economic projections presented in Table 4-36. Musselshell County would continue to grow slower than Montana or Yellowstone County. Increases in population may be mostly due to the increase of commuters to Billings (such as occurred in the Klein CCD), rather than growth in employment opportunities. Employment in Musselshell County is projected to rise only 13 percent between 2000 and 2020, much less than the 34 percent projected for Yellowstone and the 33 percent forecast for Montana. Per capita income is projected to grow, but it would remain well below the averages for Montana and Yellowstone County. The impacts associated with the proposed Mine are independent of those for the proposed Generation Plant. The negative impacts of disapproval would be minor in Yellowstone County.

Table 4-36 Baseline Economic Projections for Montana, Musselshell County, and Yellowstone County 2000 to 2020

Place/Type	2000	2005	2010	2015	2020
Montana					
Population	902,200	952,150	1,000,870	1,053,490	1,108,910
Employment	565,300	618,400	669,940	712,520	750,030
Per Capita Income (1996\$)	\$22,307	\$25,089	\$27,658	\$29,783	\$31,790
Musselshell County					

Place/Type	2000	2005	2010	2015	2020
Population	4,497	4,680	4,860	5,070	5,290
Employment	2,060	2,130	2,210	2,280	2,330
Per Capita Income (1996\$)	\$16,701	\$19,128	\$21,521	\$23,625	\$25,660
Yellowstone County					
Population	129,352	137,990	145,880	154,040	162,410
Employment	91,030	99,840	108,340	115,440	121,790
Per Capita Income (1996\$)	\$25,542	\$28,392	\$30,971	\$33,010	\$35,049

Source: National Planning Association 2002.

4.12.4 Taxes

The tax impacts of the alternatives are presented below.

Proposed Action and Action Alternatives

The Project would provide increased tax payments to the State of Montana, Musselshell County, and the Roundup School District.

The State of Montana taxes affected by this Project are the Electric Energy Production Tax (EEPT), the Wholesale Energy Transaction Tax (WETT), and the Individual Income Tax. The EEPT rate is \$0.0002 per kilowatt-hour of electricity produced and the WETT is \$0.00015 per kilowatt-hour produced. The net capacity of the plants is 700 MW. Assuming the plants run at 90 percent of capacity, annual production would be 5,518,800,000 KWH. The estimated annual payment for the EEPT is \$1,103,760, while the corresponding estimate for the WETT is \$827,820. Montana Individual Income Tax would be paid on the direct and indirect labor income associated with the Project. Using an average tax rate of 3.5 percent, the peak year Generation Plant's labor income would yield income tax revenue of \$ 2.7million (2001 dollars), and the corresponding figure for year 5 and thereafter is \$324.8 thousand (2001 dollars).

In addition, the Project would pay property taxes to Musselshell County and the Roundup School District. The taxable value of electric generating plants is equal to 6.0 percent of their assessed value. The equipment and materials cost of the Project would be about \$440 million, which translates into a taxable value of \$26.4 million. As reported in Chapter 3 (Table 3-25), the total taxable value in Musselshell County in 2001 was about \$7.2 million. Therefore, even allowing for considerable error in calculations, the Project would more than double the taxable value in Musselshell County and the Roundup School District. The current mill rate for Musselshell County is 115.75, and the corresponding figure for the Roundup School District is 237.36. Applying these rates to the estimated taxable valuation yields a figure of \$3.1 million in property taxes to Musselshell County and \$6.2 million to the Roundup School District.

The increased property tax revenue would benefit Musselshell County and the Roundup School District. If Musselshell County does not change its mill levies, there would be a significant

increase in revenue, which could be used to expand existing facilities, update infrastructure, and other uses. If Musselshell County decides to reduce its mill rates, existing property tax payers would benefit because their taxes would be reduced but services may remain the same or even increase. A large portion of the increased school property taxes would go into the state equalization account and would not be available for the Roundup School District.

No-Action Alternative

Under the No-Action alternative, any improvements dependent upon the tax base would have to seek alternate funding. Demands placed on public services dependent upon this tax base would be minimized, as population growth would be slowed.

If the Project is disapproved, the State, County, and School District must rely on the existing tax base to fund additional projects and programs. Additional demands placed on public services dependent on this tax base may be small as population growth would be slow. The impacts associated with the proposed Mine are independent of those for the proposed Generation Plant.

4.12.5 Education Services

The education services impacts of the alternatives are presented below.

Proposed Action and Action Alternatives

Based on the population forecasts presented in Table 4-33, there would be approximately 92 additional persons under 18 years of age in Musselshell County associated with the Project during the operations phase in year 5 and thereafter. Of this total, about 41 can be expected to enroll in grades K to 8, and 18 in high school.

Although the Mine is considered an existing action, it is not currently in operation. The additional students associated with the Mine need to be considered in evaluating education services capacity. Based on the forecasts in Table 4-34, there would be about 233 additional persons less than 18 years of age in Musselshell County associated with the Mine; about 105 can be expected in grades K to 8 about 44 in high school. Therefore, during the operations phase of the Project and Mine, Musselshell County can expect increased enrollment of about 146 students in grades K to 8 and about 62 students in high school.

The Roundup School District had 2000 enrollment of 425 K-8 students and 239 high school students. During the 1990-91 school year, the Roundup School District with the same facilities had enrollment of 511 in K-8 and 202 in high school. This suggests that the Roundup School District currently may have some excess capacity. In addition, as discussed in Chapter 3, class sizes are progressively decreasing; therefore, it may be possible to accommodate the increased enrollment without building new schools. There would, of course, be the need for additional staffing and other costs. Higher enrollment would increase the equalization payments from the state.

In Yellowstone County, there would be there would be approximately 41 additional persons under 18 years of age associated with the Project during year 5 and thereafter. Approximately 18 would be enrolled in K-8 and about 8 would be in high school. There would be approximately 92 additional persons under 18 years of age during year 5 and thereafter associated with the Mine.

Approximately 41 would be enrolled in K to 8 and 18 would be enrolled in high school. Therefore, during the operations phase of the Project, Yellowstone County can expect a maximum of about 59 additional K to 8 students and approximately 6 additional high school students.

Yellowstone County had about 15,100 enrolled in K-8 and 6,700 in high school in 2000. Therefore, the enrollment associated with this Project would be unlikely to cause significant impacts on the Billings School District or elsewhere in Yellowstone County.

Applying the same parameters to the peak-year population in year 3 (Table 4-33) yields a total estimated enrollment of 390 students in Musselshell County and 311 students in Yellowstone County. These figures should be considered as maximum estimates, and unlikely to be realized. The in-migrating construction workers (60 percent of the total) are less likely to bring their families with them for a temporary job.

The increased enrollment in the Roundup School District would reverse the downward trend of the last decade. Since the additional students would also increase the equalization payments from the state, there would be more resources available to the school district. There appears to be the possibility of excess capacity available to accommodate some increase in enrollment, but there may be need for school construction.

No-Action Alternative

Under the No-Action alternative, the Roundup School District would continue to experience decreased enrollment as the ever-smaller classes advance through the grade levels. Declining enrollment would mean decreases in the equalization payments from the state, according to the existing payment formula. The impacts associated with the proposed Mine are independent of those for the proposed Generation Plant.

The Yellowstone County school districts would not experience the slight increases in enrollment associated with the permanent (and perhaps some temporary) workers who choose to live there.

4.12.6 Transportation

The transportation impacts of the alternatives are presented below.

Proposed Action and Action Alternatives

Approval of the Project would increase traffic on U.S. Highway 87 as employees commute from place of residence to place of employment. This increase in traffic on Highway 87 would require additional traffic patrol and enforcement efforts. The increased traffic would peak during years 2, 3, and 4, which reflect the construction activity. Whether Generation Plant and Mine workers choose to live in Roundup or the Billings area (and appropriate housing is built or otherwise available) would determine if traffic would increase more north or south of the site. Commuter traffic should not adversely affect the overall condition of the road surface. The Project would increase the volume of traffic on a short stretch of "Old Divide Road," as employees commute to and from work; however, a greater tax base would also increase funds available for road maintenance. Semi-truck traffic for construction periods would blend with the current transport traffic creating periods of congestions.

No-Action Alternative

The No-Action alternative would not reduce the present flow of traffic on U.S. Highway 87, nor would disapproval reduce the impact of an increasing number of out-migration commuters traveling to Billings employers. The need for increased law enforcement patrols is growing, but not supported on the current tax base.

4.12.7 Utilities

The impacts of the alternatives on utilities are presented below.

Proposed Action and Action Alternatives

As discussed in Section 3.12.6, municipal water for Roundup residents is obtained from two sources. The availability of municipal water would not be adversely affected by an increased population as current availability exceeds demand. Water availability for residents outside of the city of Roundup is dependent upon wells, or water delivered to individual cisterns. Water for Generation Plant operation would be withdrawn from on-site deep wells, which would have no effect on other groundwater users in the area.

The municipal wastewater treatment center is a revised 3-cell lagoon that would be adequate for the projected increase in population in Roundup. Residents outside of the city of Roundup require individual septic systems. Solid waste is transferred to Billings, and both the transfer station and the Billings landfill have excess capacity. Commercial waste disposal services would be available through BFI Waste Systems in Billings.

No-Action Alternative

The municipal utilities provided in Roundup are ample for the current population with room for additional use. Thus, disapproval of the proposed Project would have no effect on utilities.

4.12.8 Health and Safety

The impacts of the alternatives on health and safety are presented below.

Proposed Action and Action Alternatives

Increases in crime are generally associated with population increases. Applying the statewide 1999 crime rates to the projected population figures reported in Tables 4-33 through 4-35 provides a basis for projecting changes in crime associated with the Project (Montana Department of Justice, 2001). During the peak of Generation Plant construction in year 3, there would be about 153 additional Part I crimes, with about 144 more property crimes (burglary, larceny, and motor vehicle theft) and approximately nine more violent crimes (homicide, rape, and robbery). There would be about 251 additional Part II crimes (non-violent crimes). When the Project becomes operational in year 5 and thereafter, there potentially would be about 26 additional Part I crimes, with about 24 property crimes and roughly two violent crimes. There would also be about 43 nonviolent crimes per year.

Although the Mine is considered an existing action, it is not currently in operation. The additional population associated with the Mine need to be considered in evaluating health and

safety capacity For the Mine, there would be about nine additional Part I crimes in year 1, with eight more property crimes and one more violent crime. There would be also approximately 15 more nonviolent crimes. For years 3 and thereafter, there would be 64 Part I crimes, with about 60 property crimes and four violent crimes. There would also be about 106 nonviolent crimes.

Altogether, the Project and Mine may add an estimated 217 Part 1 crimes during the peak Year 3, along with about 204 property crimes and approximately 13 violent crimes. There would also be an estimated 357 Part II crimes in that year. During the operations phase in year 5 and thereafter, there would be about 91 Part 1 crimes per year, with about 85 property crimes and approximately 6 violent crimes and approximately 149 Part II crimes.

Most of these estimated crimes would probably occur in Yellowstone County. Reported crime in Montana is heavily concentrated in the urban areas. For example, Yellowstone County accounted for about 25.3 percent of the reported 1999 crime in Montana, with only 16.0 percent of the state's population.

Musselshell County has one of the lowest crime rates in the state. In 1999, its crime rate of 455 per 100,000 persons ranked 48th out of 56 counties, and well below the statewide average of 4,099 per 100,000 persons. A total of 21 major offenses were reported in Musselshell County during 1999, including three assaults, four burglaries, and 13 larcenies.

The hospital has a current daily census of 1.3 inpatients (Dave McIver, 2002). The increase in usage that could be anticipated with an increase in population would not overwhelm the available medical facilities. The ambulance service would need additional staffing in the face of increased population; however, the potential for funding staff increases with the population. The Mental Health opportunities would increase as taxation monies supporting these benefits would increase.

The agencies responsible for fire management in the area are adequately staffed at present. An increase in population would increase the number of structures in the district, but would also bring additional volunteers to help staff the volunteer fire services.

No-Action Alternative

Under the No-Action alternative, agencies responsible for law enforcement in Yellowstone and Musselshell counties would not experience the increase in crime associated with the larger population. Most of this impact would be felt in Yellowstone County, where the crimes are more likely to be perpetrated.

Agencies responsible for health care would not see an increase in population requiring their services.

Agencies responsible for fire management would not anticipate a change in the need for intervention.

4.12.9 Well Being

The impacts of the alternatives on well being are presented below.

Proposed Action and Action Alternatives

The magnitude of potential consequences on social well-being would depend on the ability of community members to adapt to social changes resulting from the proposed Project or action alternatives. Past history in the Roundup and Bull Mountain areas with cyclical resource developments such as coal, oil, forest products, and agriculture has imparted a social history of boom and bust. Due to this pattern of life, many social experiences necessary to deal with new development already exist. This is, however, a sparsely populated area with an established and settled culture. Proposed development may be expected, but it is new and would affect social and cultural patterns. How much local growth results from the proposed development would influence the extent of the impact that mining development has on the immediate area.

Positive effects to social well-being would be realized through increased job opportunities and local spending. Since not all jobs created by the Generation Plant would be filled by local residents, and only a portion of the income would be spent locally, residents with high expectations that the Generation Plant would revitalize the area's depressed economy would experience disappointment if the Project failed to provide a large infusion of wages.

Negative effects would depend upon the extent to which the local area develops. Annual population growth rates above five percent are more likely to have deleterious impacts to communities associated with energy extraction (Lapping, et al., 1989). Rapid growth in small communities can result in higher rates of crime (property crime during expansions periods), suicide, and stress-related mortality (Hardt, 1994). In particular, residents who oppose the Generation Plant may be adversely affected by its approval. These residents may be more likely to experience feelings of anxiety, stress, and a perceived loss in quality of life. Those residents who established and joined grassroots organizations to oppose the Generation Plant probably would feel their attempts had been futile.

If, however, most of the potential workers locate, and socially and economically associate in areas outside the Roundup area, the advantages to the Project would be minimized, so, too, would the potential disruptions and advantages. If the immediate impacts on the residents to the residents of the Roundup area were to be kept to manageable levels--no more than five percent annual growth--the cumulative impacts to Roundup residents should be manageable.

As mentioned above, annual population growth rates above five percent annually can lead to significant social disruptions. These may be manifest in increased rates in divorce and broken homes (Mudock et al., 1980; Cortese and Jones, 1994). Energy extraction has been, and remains, a male dominated field. The intensity of activity during development periods pre-occupies those who are involved. The routine of work can also distract attention from adverse events in non-work settings, thus mitigating personal stresses that may occur. Females, on the other hand, are less likely to have routines that take them away from the observation of daily occurrences in their community. They are less likely to be employed, pre-occupied, or distracted. As a result, they are more likely than are males to report difficulty in coping with the dynamic changes wrought by periods of rapid social and demographic change associated with development that the Project would bring in the short term (Moen, 1980).

Assuming the baseline figures cited in Table 4-35 of this report are accurate, the annual rate of population growth in Musselshell County would be 0.8 percent, arriving at 5,290 residents in 2020. Employment in the county, however, is expected to increase approximately 13.1 percent

by 2010. This suggests that the bulk of the growth associated with the Project would reside outside of Musselshell County in more heavily populated Yellowstone County, thus minimizing disruptive effects that might otherwise be expected. Given the size of the Billings area (Yellowstone County), the proposed Project should have only a negligible impact there.

No-Action Alternative

Individuals perceiving the Generation Plant to be a negative influence on the area would view its disapproval positively, whereas those favoring it would perceive disapproval as reducing the potential for increased local income and jobs. Individuals who supported the plant may perceive that their quality of life had been adversely affected by the Generation Plant’s denial.

Anticipation of a much-needed boost to the economy would not be realized and would cause disappointment to many. This loss of an optimistic outlook for the community could decrease the feeling of social well being for some people. It is likely that community conflict among groups favoring or opposing the Generation Plant would gradually subside with no development, but interpersonal polarization would remain for years. Other development should not affect the social well-being in the Bull Mountains.

4.12.10 Summary of Socioeconomic Impacts

Table 4-37 summarizes the socioeconomic impacts expected to occur due to construction and operation of the Project or the Action Alternatives.

Table 4-37 Summary of Socioeconomic Impacts

Proposed Action	Potential Impact	Impact Severity
Generation Plant Construction	Increased demand for housing Increased housing construction, trailer court development, etc.	Beneficial, short term – to homeowners, landowners, landlords, contractors, etc. Adverse, low – to existing renters
Generation Plant Construction	Increased employment opportunities Increased average earnings per worker	Beneficial, short-term
Generation Plant Operation	Increased employment opportunities Increased average earnings per worker	Beneficial, long-term
Generation Plant Operation	Increased tax payments to Montana, Musselshell County, and Roundup School District	Beneficial, long-term
Generation Plant Construction and Operation	Increased student enrollment in area schools	Adverse, low – due to need for additional staff and infrastructure; Beneficial – increased resources due to larger equalization payments from the state of Montana
Generation Plant Construction and Operation	Increased traffic from construction workers, construction equipment, and truck deliveries	Adverse, low

Proposed Action	Potential Impact	Impact Severity
Generation Plant Construction and Operation	Increased burden on utilities (water, sewers, solid waste, etc.) due to population increases	Adverse, low – there is adequate existing capacity and a projected increased tax base
Generation Plant Construction and Operation	Increased crime due to population increases	Adverse, low – increased tax base would allow for more law enforcement
Generation Plant Construction and Operation	Increased burden on fire protection services, ambulance, and medical facilities due to population increases	Adverse, low – increased tax base would allow for improved services
Generation Plant Construction and Operation	Altered sense of community culture and well-being	Beneficial – opportunities for new membership in clubs, churches, etc. Adverse, low – disruption of established social patterns

Source: Bull Mountain Development Company, LLC., 2002a.

4.12.11 Mitigation Measures

No Project actions specific to socioeconomics are enforceable by an agency. The regulatory agency does not have the authority to create mitigation measures that they can enforce, without the direct consent of the Project proponent.

Most of the Project impacts to socioeconomics would be beneficial, so no mitigation measures would be recommended. Potential mitigation measures to further reduce or eliminate impacts to land use and safety would also minimize some adverse socioeconomic impacts. These measures are included in Chapter 2, Section 2.2.5 in the Construction and Maintenance Access subsection, as well as the Land Use and Safety subsection.

4.13 Irreversible and Irretrievable Commitment of Resources

This section details the effects where there would be a permanent loss of resources or where resources would be inaccessible or unusable for any pre-Project occurrences. The Project would result in an irreversible and irretrievable commitment of resources from direct consumption of materials used during construction and operation including fuel to operate equipment, equipment created for the Project that would not be usable or recyclable at the end of the life of the Project and all coal reserves used to fuel the Generation Plant.

Approximately 208 acres of mostly grass/shrubland habitat with some ponderosa pine would be irreversibly replaced by the Generation Plant. Portions of a 28 mile long and 300-foot wide right-of-way would also be irreversibly replaced by transmission structures and access roads associated with the Project; although, much of the transmission right-of-way would remain available for wildlife habitat, cattle grazing and agricultural practices. Due to the widespread, common nature of this habitat, and because no federally-listed Threatened and Endangered

species are known to occur in these areas, the loss to wildlife habitat, cattle grazing and agricultural practices would result in a low impact to these resources.

If cultural or paleontological resource are discovered during Project construction and cannot be avoided, recovery of these resources would ensure no irreversible and irretrievable loss to cultural resources.

The Project operations would result in the consumption of approximately 8,000 tons of coal per day from the adjacent Mine, which would be irreversibly replaced by the generation of electricity. The loss of these coal reserves would be offset by the benefit of electricity generation by the Project.

4.14 Cumulative Impacts

4.14.1 Overview

Cumulative effects result from the incremental impact of the Proposed Action when added to other past and present actions, and future actions under state review. MEPA requires an agency to consider all past and present state and non-state actions; however, for future actions, only those actions under concurrent consideration by a state agency need to be included in the assessment.

The following actions were considered in the cumulative analysis of the Project:

- Residential Development
- Commercial Development
- Industrial Development
- Infrastructure Development

Residential and Commercial Development

Currently residential and commercial developments are minimal in the Project Study Area and surrounding county. Eight rural residences are located within a mile of the Project. The City of Roundup, located approximately 13 miles to the north, is the closest urban development.

No new residential developments are known to be planned for the Project Study Area. However, given the amount of recent residential development, and the amount of land in the Project Study Area that is subdivided, it is reasonable to assume that a small level of development would occur in the future.

The nearest commercial establishment is the Brandin' Iron Saloon, which is located along U.S. Route 87, approximately two miles north-northwest of the Project Study Area. A convenience store and a log furniture store are proposed along U.S. Route 87, approximately two miles northwest of the Project Study Area. The next closest commercial establishment is located south of the plant site approximately five miles away. Other plans for the area include a recreational vehicle park and golf course.

Industrial Development

The PM Mine, an underground coal mining operation, was located partially in Section 14, east of the Project Study Area. The PM Mine ceased operation in the 1990s, but the Bull Mountains Mine No. 1 plans to resume mining of the same area. The environmental impacts of this Mine were described by the Montana Department of State Lands (MDSL) in a 1992 Final Environmental Impact Statement (Montana Dept. of State Lands, 1992). No new coalmines or other industrial developments are known to be proposed for the Project Study Area.

Infrastructure Development

Roads

Portions of U.S. Route 87 between Roundup and Billings were upgraded during the 1990s. The only known proposed future upgrades are the construction of acceleration-deceleration lanes where Old Divide Road (the proposed access road to the Project Study Area) intersects Route 87. Construction of these lanes would be expected to disturb relatively small amounts of land already subject to disturbance from traffic and maintenance activities on Route 87.

Transmission

The major backbone of the Montana transmission system is the two 500kV lines that run east to west across the state and through the Broadview Substation (the Project connection point). The 500kV lines connect to the Bonneville Power Administration (BPA) system at Garrison Substation, west of Broadview Substation. Additionally, 230kV transmission connects Broadview Substation to the PacifiCorp system at Yellowtail Substation southwest of the Project Study Area.

According to BPA, major transmission improvements to the BPA system are planned. These improvements would include substation upgrades and transmission line additions between Montana and the Pacific Northwest.

A recent regional transmission study by Western Area Power Administration (WAPA, 2002) determined that export capacity for Montana-generated power is limited and additional high voltage lines and substation upgrades would be required to alleviate congestion to existing transmission. The rules and requirements of new transmission of power are regulated by the Western Electric Coordinating Council (WECC) with system impact studies required for any requests to connect to the western transmission grid system.

The transmission lines from the Project would follow the existing railroad right-of-way for the Mine railroad to Broadview Substation, where the lines would connect to the NorthWestern Energy system. No additional land would be disturbed.

Cumulative effects from the above actions were assessed for each of the resources included in Chapters 3 and 4. The area of impact and level of impacts to these resources are described in the following sections.

4.14.2 Impacts to Resources

Air Resources

This section summarizes cumulative effects of the Project on air resources. A more detailed discussion of the cumulative impact assessment methods and results is included in Appendix B.

Impacts from Offsite Sources

Demonstration of MAAQS, NAAQS, and PSD increment compliance, either within the facility's radius of impact, or near surrounding Class I areas, requires inclusion of impacts from other emission sources that could affect air quality. All major and minor sources within the radius of impact and all major sources within 50 km beyond the radius of impact were included in the MAAQS and NAAQS compliance demonstrations. Only those sources consuming PSD increment (PSD sources) were included in the PSD increment compliance demonstration.

Modeled impacts from the NAAQS/MAAQS modeling analysis were added to the background concentration for the area to determine compliance with the MAAQS/NAAQS. The modeled impacts from existing PSD sources were added to the modeled impacts of the proposed source to determine PSD increment compliance.

Cumulative Ambient and Class II Analyses

Since the impacts from the Project, by itself, were above the PSD modeling significance levels, a cumulative impact analysis for both ambient standards and Class II increments was conducted. The ISC model was used to predict the cumulative ambient and Class II impacts.

Off-site Emitting Sources for Ambient and Class II Analyses

The major Billings/Laurel SO₂-emitting industrial sources were included in the SO₂ MAAQS and NAAQS compliance demonstrations. The predicted NO₂ impacts from the Project are so low that inclusion of other NO_x sources is not considered necessary. Table 4-38 summarizes the potential emissions for the Billings/Laurel SO₂ sources that are used in the ambient analysis.

Table 4-38 Potential Emissions from Billings/Laurel SO₂ Emission Sources

Facility	3-hour Emission Limit (lb/3-hr)	24-hour Emission Limit (lbs/24-hr)	Annual Emission Limit (tons/yr)	Rep. Stack Height (m)	Stack Temp. (K)	Stack Velocity (m/s)	Stack Diameter (m)
ExxonMobil Refinery	6,664	53,154	9,700	76.7	583	13.8	2.96
Yellowstone Energy Limited Partnership	2,204	16,320	2,978	60.6	450	27.4	2.7
Conoco Refinery	2,113	16,901	3,084	53.6	477	47.46	97
Montana Sulphur & Chemical Co.	9,292	74,336	4,544	100	542	10.4	1.07
PPL-Corette Plant	4,162	33,296	5,000	106.7	389	36.58	3.51
Western Sugar	944.7	7,558	797	54.9	309.7	8.24	2.93

Facility	3-hour Emission Limit (lb/3-hr)	24-hour Emission Limit (lbs/24-hr)	Annual Emission Limit (tons/yr)	Rep. Stack Height (m)	Stack Temp. (K)	Stack Velocity (m/s)	Stack Diameter (m)
Cenex Refinery	8,116	64,957	11,849	60.81	495.1	17.3	2.07

Source: Bull Mountain Development Company, LLC., 2002b; Steven T. Wade, 2002a

^aEmissions were assumed to emit from a single stack at each source because of the large distance between the Project and the Billings/Laurel sources

Cumulative NAAQS and MAAQS Impacts

Table 4-39 compares the highest modeled impacts from the Project in combination with offsite sources with the appropriate NAAQS/MAAQS. In each case, the peak measured ambient concentration has been added to the highest modeled impact to determine the total concentration for comparison with ambient standards.

Table 4-39 Cumulative NAAQS/MAAQS Impacts

Pollutant	Average Period	Modeled Impact ^a ($\mu\text{g}/\text{m}^3$)	Existing Conc. ($\mu\text{g}/\text{m}^3$)	Total Conc. ($\mu\text{g}/\text{m}^3$)	PSD Modeling Sig. Levels ($\mu\text{g}/\text{m}^3$)	NAAQS ($\mu\text{g}/\text{m}^3$)	MAAQS ($\mu\text{g}/\text{m}^3$)
NO ₂	Annual	1.12	1.26 ^d	2.38	1	100	94
	1-hour ^b	266	15 ^d	281	--	--	561
SO ₂	Annual	3.42	0.97 ^d	4.15	1	80	52
	24-hour ^b	40.5	8.58 ^d	49.1	5	365	262
	3-hour ^b	201	26.0 ^d	227	25	1,300	---
	1-hour ^c	480	41.6 ^d	522	--	--	1,300
CO	8-hour ^b	33.6	1,125	1,159	500	10,000	10,350
	1-hour ^b	105	1,725	1,830	2,000	40,000	26,450
PM ₁₀	Annual	1.69	9	10.7	1	50	50
	24-hour ^b	26.3	53	79.3	5	150	150

Source: Bull Mountain Development Company, LLC., 2002b

^aRoundup Power Project and offsite source impacts

^bBased on High Second High Impact

^cBased on 19th High Impact

^dAveraged from onsite monitoring data collected from January 1, 2002 thru July 15, 2002

The cumulative NAAQS/MAAQs analysis shows that the impacts are above the PSD modeling significance levels but below the ambient standards. Therefore, predicted cumulative impacts from the Project are considered moderate.

Cumulative Class II Increment Impacts

The PSD Class II designation allows for moderate growth or increases in ambient pollutant concentration within certain limits above baseline concentrations. The allowable increase is known as the PSD increment. Industrial sources proposing construction or modifications must demonstrate that impacts from the proposed emissions together with emissions from other PSD sources would not cause ambient pollutant concentrations to increase above the allowed increment in all areas.

Emissions from the Mine are assumed to consume PSD Class II increment for PM₁₀, NO₂, and SO₂. NO₂ and SO₂ emissions from the Mine are very low, and impacts outside the Mine boundary are considered negligible. No other sources consume SO₂ or NO₂ PSD Class II increment within the radius of impact.

Modeling for receptors within the Class II area near the plant was performed using the ISC model. The results in Table 4-40 show that the Project would be in compliance with Class II PSD increments.

Table 4-40 Cumulative PSD Class II Increment Impacts

Pollutant	Average Period	PSD Class II Impact (µg/m ³)	PSD Class II Increment (µg/m ³)	PSD Modeling Sig. Level (µg/m ³)
NO ₂	Annual	1.12	2.5	1
SO ₂	Annual	2.45	20	1
	24-hour	18.5 ^a	91	5
	3-hour	51.8 ^a	512	25
	3-hour	51.8 ^a	325 ^b	25
PM ₁₀	Annual	1.69	17	1
	24-hour	26.3 ^a	30	5

Source: Bull Mountain Development Company, LLC., 2002a

^aBased on High Second High Impact

^bMontana maximum allowable increase above minor source baseline

The cumulative Class II increment analysis as outlined in the above table shows that the impacts are above the PSD modeling significance levels, but below the allowed increments. Therefore, the predicted impacts, with respect to the Class II increments, are considered moderate.

Cumulative Class I Increment Analysis

The predicted modeling impacts for the Project were above the PSD Class I increment significance levels (proposed by EPA but not adopted as regulation). Therefore, a cumulative Class I increment analysis was completed to address impacts from the Project and other major

sources in the region. The focus of the cumulative PSD Class I analysis was on impacts to nearby PSD Class I areas, Yellowstone National Park (YNP), UL Bend Wilderness Area (UL Bend), North Absaroka Wilderness (NAW), and Northern Cheyenne Indian Reservation (NCR). The following paragraphs summarize the cumulative Class I increment impacts.

The cumulative PSD Class I increment impacts for the 24-hr and 3-hr SO₂ Class I increments at YNP, NAW, and UL Bend are above the PSD Class I significance levels but below the Class I increments. Therefore, these predicted impacts would be considered moderate. All of the other modeled PSD Class I increments at these Class I areas are below the PSD Class I significance levels. Therefore, the predicted impacts would be considered low.

The predicted cumulative NO_x and PM₁₀ PSD Class I increment impacts at the NCR were considered moderate to low. Cumulative SO₂ model-predicted impacts were above the PSD Class I increments and are considered moderate to high. The high increment impacts are mainly due to the emissions from Units #3 and #4 at the PPL facility in Colstrip. During these high impacts, the predicted impacts from the Project were considered low (below the PSD Class I significance levels).

Appendix B contains a more thorough analysis of the PSD Class I modeling impacts on the four Class I areas.

Cumulative Visibility Analysis

As part of assessing air quality impacts of the Project in combination with impacts of other major sources in the region, a cumulative visibility analysis was completed. The focus of the cumulative visibility analysis was on impacts to the PSD Class I areas within 200 km of the Project: YNP, UL Bend, NAW, and NCR.

The FLAG Guidance document (U.S. Forest Service, et. al., December 2000) indicates that a cumulative visibility analysis is expected when an individual source shows impacts that exceed a 5% change in light extinction. The predicted modeling impacts from the Project exceeded the 5% change in light extinction criteria in three PSD Class I areas (YNP, NAW and UL Bend), so a cumulative impacts analysis was triggered. The NCR is not a mandatory PSD Class I area (not designated by the Federal Clean Air Act), so a visibility analysis was not required by regulation.

Procedures for conducting a cumulative visibility analysis are described in the FLAG Guidance document (Section D.2). While the FLAG Guidance document outlines a process for assessing potential visibility degradation from industrial sources of air pollution, CALPUFF modeling by the proponent has generated a number of questions on model algorithms, methodology, and results. These questions are the subject of discussion among the proponent, the FLM, and DEQ. Because the points of disagreement and discussion are still under review, the different methods used to assess visibility degradation are reported in this section. Additional detail on the analyses and methodologies can be found in Appendix B.

Three approaches to modeling cumulative visibility impacts have been applied in determining projected impacts on PSD Class I areas as follows:

Scenario #1: Establishes a visibility baseline date in 1996 to reflect the availability of baseline visibility monitoring data in Class I areas. Emissions of sources constructed or proposed since that date are included in the modeling to determine the cumulative

visibility impact. This scenario proposed by the proponent reflects a practical approach to determining visibility based on the initiation of visibility monitoring. It does not include impacts of all major sources permitted since the PSD baseline date of 1975; therefore, it is less conservative and not favored by the FLMs. Model-predicted results indicate that the Project would be a contributor to days with over a 10% change in light extinction at YNP and NAW. These impacts would be considered high for this EIS document. The predicted impacts at the UL Bend would be considered moderate since the impacts are below 10%.

Scenario #2: Includes increases (but not decreases) in emissions of major sources permitted since the PSD baseline date of 1975 in the cumulative visibility modeling. The Scenario #2 modeling was conducted by the FLMs and includes additional major emissions sources in the cumulative analysis. Results show that emissions from Colstrip Units #3 & #4 are projected to cause high visibility impacts at YNP, UL Bend, and NAW. The Project shows significant contributions (>0.4%) to the high impacts at YNP, UL Bend, and NAW.

Scenario #3: Includes major source emissions increases and decreases since the PSD baseline date of 1975. Scenario #3 includes emissions decreases resulting from the shutdown of two major sources of sulfur dioxide in Montana and from adoption of a new State Implementation Plan (SIP) for controlling sulfur dioxide emissions decreases from sources in the Billings area. Results show an improvement from Scenario #2. However, model results show the Project continues to contribute to visibility impacts above 0.4% change in light extinction.

The proponent has reviewed the CALPUFF modeling results on the days when the predicted change in light extinction levels are above 10%. They have found that the days with the predicted high change in light extinction levels are days with high relative humidity. Based on these findings, the proponent has asserted that the model is likely over predicting real conditions on these days. They believe that precipitation events are likely to occur during these high humidity days, and that any impacts from industrial source emissions would be obscured by natural conditions. Additional discussion and evaluation of this concern along with the model predictions are anticipated as the FLMs determine whether a finding of adverse impact will be issued.

Appendix B contains a more thorough analysis of the Class I visibility impacts.

Water Resources

Surface and groundwater resources are present in the Generation Plant and Transmission System Study Area. Wells would allow access to groundwater at depths of approximately 8500 feet bgs from the Madison Aquifer.

No surface water would be intentionally impounded for beneficial use in the Project. Surface storm water would be captured to prevent discharge from the Project site. This captured water would be used in the disposal of fly ash and spent FGD reactant as well as for the disposal area irrigation system. The use of captured storm water would be purely a means of disposing of unwanted water as the groundwater wells would be fully capable of supplying the water needs for the entire Project.

Potential surface water and/or groundwater contamination would be mitigated by the implementation of a “zero discharge” sediment control system. This system would contain all water used in the Generation Plant operations, along with storm water diverted into sediment control ponds.

There are no local users of the Madison Aquifer in the Generation Plant Study Area and water used for the Project would be small in comparison to the total water resource available from that source. Local homeowners and ranchers currently access shallow aquifers for water. Elimination of the recharge area beneath the Generation Plant may influence these local shallow aquifers and cause a slight decrease in productivity. The Mine could contribute to cumulative effects on this shallow aquifer through dewatering practices during coal extraction.

Wildlife Resources

The Final Environmental Impact Statement prepared for the Mine (Montana Department of State Lands, 1992) concluded that impacts to fish and wildlife would be minor in the short-term and negligible in the long-term, with the exception that if mitigation measures for spring, seep, pond, and wetland effects failed, there could be an irreversible and irretrievable loss of wildlife associated with these features. Construction and operation of the Project would not affect spring, seep, pond, wetland habitat (i.e., there would be no direct disturbance of these habitats, nor would existing features be dewatered by the groundwater withdrawals needed for the Project). Therefore, cumulative effects that the Project would add would be low.

Subdivisions and residential developments in the Generation Plant and Transmission System Study Areas have resulted and probably would continue to result in the loss and alteration of wildlife habitat; intentional and unintentional harassment of wildlife; invasion of non-native wildlife species that are adapted to human developments, such as European starlings (*Sturnus vulgaris*) and house sparrows (*Passer domesticus*); and intentional and unintentional mortalities of wildlife through activities such as rodent or predator control, collisions with vehicles, and legal or illegal harvest of game species. When residential developments are constructed in previously rural settings, wildlife management activities of agencies such as the Montana Department of Fish, Wildlife and Parks (MDFWP) may be impeded. Some species of wildlife may habituate to these developments, while others may be at least seasonally displaced from otherwise favorable habitat. Subdivision and residential developments may have already influenced the occurrence, distribution, and abundance of wildlife near the Generation Plant and Transmission System Study Areas. The degree and magnitude of wildlife impacts that could be cumulative to the Project generally would be considered minor.

Construction of acceleration-deceleration lanes on U.S. Route 87 would not be expected to disturb substantial areas of previously undisturbed wildlife habitat. These lanes would be located adjacent to the ephemeral headwaters of Halfbreed Creek, and runoff controls used during construction would be expected to contain sediment sufficiently so that the impact to wildlife would be low. The Project would have no impact on downstream fisheries. The degree and magnitude of wildlife impacts that could be cumulative to the Project generally would be considered minor.

Transmission lines in the Transmission System Study Areas would be permitted under appropriate regulatory authorities. Depending on the mitigation measures applied under these

authorities, transmission lines could create hazards to birds, either through transmission line strikes or electrocution. However, the separation of the conductors and the insulator size of the proposed and alternative Transmission System would be such that there should be little danger of even large birds making simultaneous contact with the energized conductors and ground to cause electrocution.

In parts of the United States, there has been a desire to provide nesting platforms on transmission structures to provide additional nesting sites for certain bird species. In other areas, nesting and perching sites are discouraged with the placement of devices that make it difficult for birds to land on the structures. If perching sites were located in habitats of species such as sage grouse, or sharp-tailed grouse, increased predation by raptors could be detrimental to these species. For this reason, it may be desirable to discourage perching, as discussed above.

Overall, the degree and magnitude of the Transmission System impacts on wildlife that could be cumulative to the Project are speculative but generally would be considered low.

Cultural Resources

Cultural resources in the general region are protected by the Montana Antiquities Act if they are on state lands and by the Archaeological Resources Protection Act, the NHPA, and other laws and regulations if they are on federal land. In addition, cultural resources are protected by the NHPA if they are in the area of potential effect for a federally funded or permitted undertaking. Cultural resources located on private property in Montana do not receive the same level of protection.

The Bull Mountains Mine FEIS (Montana Dept. of State Lands, 1992) found 13 cultural resources (10 lithic scatters, a homestead, a stone circle, and a prehistoric/historic site) in the proposed life-of-mine area. Five of the lithic scatters and the stone circle were recommended as being eligible to the National Register pending further investigation. However, the Bull Mountains Mine FEIS (Montana Dept. of State Lands, 1992) also estimated that as many as 230 undiscovered National Register-eligible prehistoric sites could be disturbed during construction and operation of the Mine.

It is possible that cultural resources exist within or next to the existing right-of-way for U.S. Route 87. Improvements to U.S. 87, if federally funded, would be required to comply with Section 106 of the NHPA.

Further residential development in the Bull Mountain area could result in disturbance to undiscovered cultural resources. There has been no attempt to inventory these resources.

Together these actions could result in a large amount of disturbance to National Register-eligible cultural resources. Only some of the resources would likely be protected by Section 106 of the NHPA. The Project would contribute to this cumulative effect, but its contribution would be relatively small compared to hundreds of cultural resources that could be disturbed by other actions in the area.

Cumulative impacts to traditional cultural properties are difficult to estimate without additional information from affected Native American organizations. In 1990, tribal and traditional representatives of the Crow, Northern Cheyenne, Atsina or Gros Ventre, Assiniboine, and Shoshone were contacted regarding potentially sensitive resources along the proposed railroad

right-of-way through the Bull Mountains. This consultation included visits to the area by Tribal representatives (R. Bohman, 2002; Tetra Tech 1991). Concerns about potential impacts were expressed. Therefore, if the Tribes identify specific concerns about the effects of the proposed action on traditional cultural properties, the Project could contribute to cumulative effects as well.

Visual Resources

Developing an electrical Generation Plant on the Project site would cumulatively contribute to the landscape change of this area from rangeland to industrial development. The site is positioned among other existing industrial facilities, as it is located next to the Mine and it's to be constructed railroad spur. However, because some of the land near the Generation Plant and Transmission System Study Areas is currently being grazed for livestock, nearby residential viewers may feel that this Project would continue to transform the rural agricultural views from their homes to one that is more intensely developed.

Cumulative visual impacts from the Transmission System construction and operation would be considered moderate because the Transmission System would be sited away from several high sensitivity viewpoints. However, the width and cumulative effects of this corridor could increase over time as other linear facilities may locate along the proposed Transmission System corridor in the future.

The cumulative visual impacts associated with the Transmission System are expected to be minor in those areas where transmission lines currently exist, which is the case from MP 23.6 to 28. The existing linear corridors from MP 23.6 to 28 are usually viewed as lower impact locations for new linear facilities.

Noise

The Mine and associated railroad operations would increase ambient noise levels at the sensitive receptors near the Generation Plant and Transmission System Study Areas. Although the combination of noise from the Project and noise from the Mine and railroad would increase the L_{dn} levels at the sensitive receptors, the estimated cumulative L_{dn} is not predicted to exceed EPA noise guidelines, if additional noise control measures are installed as discussed earlier in Section 4.10. By not installing additional noise measures, a substantial noise level increase would result with a potential for nuisance complaints from neighbors.

The other actions that have been identified as potentially having cumulative effects (residential development, Route 87 lane construction, and transmission line construction) would also slightly increase ambient noise levels at the sensitive receptor locations, but the cumulative effect would be a temporary effect during construction and periods of maintenance. Ongoing noise impacts from these cumulative sources would be low.

Socioeconomic

Construction and operation of the Project and Mine could result in an increase in residential, commercial and industrial development, with associated population increases and additional demand for public and private services and facilities.

Population

Cumulatively, the two operations would directly add nearly 5,300 persons to the two-county area population during peak construction. Over the longer term, the Project-related population would increase by as many as 2,200 persons (Table 4-35). However, it is likely that the bulk of the growth associated with the Project would reside outside of Musselshell County, in the more heavily populated Yellowstone County, thus minimizing effects on the Project Study Area. Some of this impact could be spread to the larger town of Billings, outside the Project Study Area, where a project this size would have only a negligible impact.

Taxes

The equipment and materials cost of the Project would have an estimated taxable value of \$26.4 million. With the total taxable value in Musselshell County in 2001 at about \$7.2 million, the Project would significantly increase the taxable value in Musselshell County and the Roundup School District. As a result, Musselshell County could potentially reduce its mill rates and still maintain the same or possibly increased services currently paid for by property owners.

Transmission Infrastructure

Studies completed by NorthWestern Energy indicate that the Project's output would be restricted during an outage of one of their two existing 500kV lines in Montana. However, under some single line outage conditions and with additional improvements at the Broadview Substation and the Garrison Substation, the plant could maintain full output. These same substation improvements would also increase the ability of the Montana transmission system to transport considerable additional power through and out of the state. These improvements do not require the addition of new transmission lines for this Project other than the power lines to connect the generators to the NorthWestern Energy transmission system.

It is expected that some of the output from the Project would be utilized in the state of Montana by existing utilities and customers, but most of the power would be exported out of the state. Exports would be to the northwestern U.S. market and to the south through Wyoming. Much of the power is likely to flow on the lower voltage (100/161/230kV) portion of the NorthWestern Energy system.

The Project as well as all other proposed new generating facilities would be required to install and coordinate protective relay Remedial Action Schemes (RAS) to protect the transmission system integrity and stability. The RAS would be required regardless of the completion order of the Project.

The location of the Project within the NorthWestern Energy transmission system would have some clear benefits to the network. Currently, the area around Billings experiences low voltage during some transmission line outage conditions. The Project would bolster the voltage during single line outages, thus improving the transfer of electricity through the 500kV lines, as well as maintaining voltage in the Billings area.

The transmission lines from the Project would follow the existing railroad right-of-way for the Mine railroad to Broadview Substation, where the lines would connect to the NorthWestern Energy system. No additional land would be disturbed. There would be phase shifting transformers required to force flow into the Montana - Idaho path in a northbound direction, without these significant capability increases cannot be realized even with substation and

transmission upgrades. Independent studies exist with identified upgrades. These studies are all the private intellectual property of BPA, UAMPS, NorthWestern Energy, and Pacificorp.

CHAPTER 5 CONSULTATION AND COORDINATION

5.1 Introduction

The action required by the Montana Department of Environmental Quality (DEQ) is to make a decision to issue or deny the necessary DEQ-authorized permits to construct and operate the Project. The primary DEQ authorization is granting a Final Air Quality Permit to the Project proponent. This permit action is required under the Montana Clean Air Act 75-2-201 et seq., Montana Code Annotated (MCA), and Administrative Rules of Montana (ARM) 17.8.701 et seq. This Draft Environmental Impact Statement (DEIS) is being prepared to comply with the Montana Environmental Policy Act (MEPA). The DEIS focuses on major actions resulting from the Project that may have significant impacts on the human environment. The Project proponent plans to begin commercial operation of the Project in November 2006.

A coordination program was carried out for the Project to ensure that all appropriate members of the public and federal, state, and local agencies were contacted, consulted, and given an adequate opportunity to be involved in the process. This section describes the agency and public scoping process, the public information program, and the issues and concerns identified from agency and public comments.

On January 18, 2002, the Project proponent published a public notice of the application submittal in the Billings Gazette. On January 23, 2002, the Project proponent published a public notice of the application submittal in the Roundup Record Tribune and the Winnett Times. A completeness review was completed by the DEQ. An incompleteness letter was sent to the Project proponent within 30 days of application submittal. Following this letter, a series of correspondence ended with a draft permit issued on August 12, 2002. DEQ published a public notice of permit issuance in the Billings Gazette on August 15, 2002. Comments were received on the draft permit.

5.2 Agency Consultation and Coordination

To begin the agency scoping process, federal, state, and local agencies with an interest in the Project or the Project study area were contacted and asked to provide comments about the Project, identify issues that would need to be addressed, and supply data, information, and/or mapping. On January 15, 2002, copies of the application were forwarded by DEQ to the following four agencies:

- USDI Fish and Wildlife Service, Denver - Ellen Porter
- USDA Forest Service, Missoula - Ann Acheson
- National Park Service, Denver - Don Codding
- US Environmental Protection Agency, Denver - Catherine Collins

Copies of the draft permit and a letter to the Project proponent were copied to the following stakeholders:

- USDI Fish and Wildlife Service - Ellen Porter
- National Park Service - Don Coddling
- USDA Forest Service - Ann Acheson
- Bison Engineering, Inc. - Joe Lierow
- Montana Environmental Information Center - Patrick Judge
- Billings Gazette - Clair Johnson
- Environmental Defense Fund - Carrie Atiyeh
- Greater Yellowstone Central Labor Council - Tom Curry
- Wilbur Wood - private citizen
- US Environmental Protection Agency, Denver - Catherine Collins
- DEQ, AQCR 140, Jim Hughes

The following agencies, as well as those listed above, will be sent the DEIS in electronic or hardcopy format:

- Department of Natural Resources and Conservation - John Tubbs and Andy Brummond
- Montana Fish, Wildlife and Parks - Chris Smith
- Montana Department of Commerce - Gary Morehouse
- Montana Department of Transportation - Sandra Straehl
- Montana State Historic Preservation Office - Josef Warhank

5.3 Public Consultation and Coordination

Public comments on the scope of the MEPA review were also accepted by mail during the scoping period, March 20 to April 19, 2002. On April 4, 2002, a public scoping meeting was held by the DEQ in the City of Roundup. The purpose of this meeting was to identify issues and concerns that the public believed needed to be analyzed in the environmental review under MEPA. On October 18, 2002, a letter was sent to all who showed an interest in the Project and registered on the mailing list at the scoping meeting. The letter indicated that an EIS was being prepared and asked for input regarding the format each interested party would prefer to receive the EIS (CD, hardcopy, or executive summary).

In addition, the owners of the Project have sought public participation by making three presentations to the Legislature's Transition Advisory Committee, by participating in the Governor's Conference on Economic Development on March 7, 2002, in Billings, and by making a presentation to the executive board of the Big Sky Economic Development Authority

in Billings. A summary of public, federal, and state resource management agencies issues and concerns is included in Chapter 1, Section 1.5.

5.4 Native American Consultation and Coordination

Agencies involved with federal undertakings have obligations to consult with Native American organizations under the National Historic Preservation Act (NHPA), 36 CFR Part 800 (as revised January 11, 2001), and other laws and regulations. Section 101(d)(6)(B) of the NHPA requires that agency officials “consult with an Indian tribe or Native Hawaiian organization that attaches religious and cultural significance to historic properties that may be affected by an undertaking.” The agency must also provide the Indian tribe with a reasonable opportunity to identify concerns about historic properties, advise on the identification and evaluation of historic properties, including those of traditional religious and cultural importance, articulate its views on the undertaking’s effects on such properties, and participate in the resolution of adverse effects (36 CFR Part 800.2(c)(ii)(A)).

While the Project is not a federal undertaking, it is following the guidelines of MEPA. MEPA requires agencies to conduct thorough, honest, unbiased, and scientifically based full disclosure of all relevant facts concerning impacts on the human environment that may result from agency actions. For identifying and evaluating cultural resources under MEPA, the Montana State Historic Preservation Office (SHPO) recommends using Section 106 of the NHPA and 36 CFR Part 800 as guidelines (J. Warhank, personal communication, 2002).

The Northern Cheyenne Tribe submitted comments on the draft permit on August 26, 2002.

On January 11, 2002, a letter was sent to the Crow Tribal Cultural representative by Ethnoscience, Inc. on behalf of the Project proponent describing the Project and the results of the survey in the vicinity of the proposed generation plant. Four follow-up phone calls were made the same month, but the Crow Tribe did not respond (Pouley, 2002).

The DEQ sent letters to the following Native American groups on October 24, 2002, inquiring about any concerns regarding the Project:

- Crow Tribal Council
Mr. Vincent Goes Ahead, Acting Chairman
Crow Agency, MT 59022
- Northern Cheyenne Tribal Council
Ms. Geri Small, Chairman
Lame Deer, MT 59043
- Eastern Shoshone Business Council
Chairman
Fort Washakie, WY 83514

CHAPTER 6 LIST OF PREPARERS

Preparer	Area of expertise	Education
<i>Montana Department of Environmental Quality</i>		
Greg Hallsten	Permitting and Compliance	B.S. Wildlife Biology, University of Montana B.S., M.S. Range Management, University of Wyoming
Dan Walsh	Air Quality Permitting	B.S. Environmental Engineering, Montana Tech of the University of Montana
Dave Klemp	Air Quality Permitting	B.S. Engineering Science, Montana College of Mineral Science and Technology, 1991 M.S. Environmental Engineering, Montana College of Mineral Science and Technology, 1994
Deborah Skibicki	Air Quality Permitting	B.S. Chemical Engineering, Montana State University M.S. Industrial and Management Engineering, Montana State University
Tom Ellerhoff	Director's Office	B.S. Science Journalism, Iowa State University
Brian Heckenberger	Water Permitting	B.S. Geology, University of Vermont
<i>POWER Engineers, Inc.</i>		
Jim Jensen	Project Manager	M.A. Environmental Studies, Mankato State University, B.S. Landscape Architecture, South Dakota State University
Lisa Grise	EIS Coordinator	M.S. Human Dimensions of Wildlife Management, Michigan State University B.S. Agriculture, University of Georgia
Bob Kannor	Technical Coordinator/noise resources	M.S. Engineering, Environmental Engineering, San Francisco State University B.S. Engineering, Electro-mechanical, San Francisco State University
Tom Dildine	Visual Resources	B.S. Arch. Landscape Architecture, University of Idaho
Alicia Taylor	Quality Control	B.S. Communications, University of Missouri
Mark Arana	Fish/Aquatics	M.S. Wildlife Science, New Mexico State University B.S. Fish and Wildlife Science, University of Idaho
Bob Mott	Socioeconomics	M.A. Economics, University of California, Berkeley

Mark Schaffer	Land Use	M.S. Industrial Hygiene, Central Missouri State University B.S. Geography, Arizona State University
Kevin Lincoln	Vegetation/Wetlands	B.S. Resource Recreation and Tourism, University of Idaho
Aaron Ames	Geographic Info. Systems	B.S. Biology, Boise State University
Mark Gerber	Wildlife	B.S. Biology, Boise State University
Bonnie Clark	Editing/document prep	A.A. Marketing & Business Administration, Stevens Henegar College, Ogden Utah
Amanda Orthel	Editing/document prep	Currently in Marketing, Boise State University
Steve Anderson	Visual Simulations	
Barbara Perkins	PWC Site Administrator	A.A. Behavioral Science, College of Marin, California B.A. Anthropology, bio-medical specialty, California State University
Mike Strand	Quality Control and Technical Editing	B.S. Forest Resources, University of Idaho
Dave Lewis	Technical Editing	M.A. Interdisciplinary Studies, Southern Oregon State College B.A. General Studies, Southern Oregon State College

Kleinfelder

Andrew Mork P.G., C.HG.	Geology, Soils, Groundwater	M.S. Geology, Eastern Washington State University B.A. Geology, University of Montana B.A. Zoology, University of Montana
Gregory Wittman P.G.	Groundwater, Geology	M.S. Geoscience/Hydrology, Montana Tech of the University of Montana B.A. Geology, University of Montana
Kent Zenobia, Ph.D.	Waste Stream Eval.	M.S. Environmental Engineering, Drexel University B.S. Civil Engineering, New Jersey Institute of Technology
James Rudolph, Ph.D.	Cultural Resources	PhD Anthropology, University of California, Santa Barbara M.S. Anthropology, Southern Illinois University, Carbondale B.A. Anthropology, University of Georgia
Jeanne Pepalis	Cultural Resources	M.A. Anthropology, Northern Illinois University B.A. Anthropology, Northern Illinois University

Bison Engineering, Inc.

Joe Lierow	Air Quality	B.S. Environmental Engineering, Montana Tech of the University of Montana
Jeffery Chaffee	Air Quality	M.S. Civil/Environmental Engineering, Oregon State University B.S. Environmental Engineering, Montana College of Mineral Science and Technology
Michael Machler	Air Quality	B.S. Meteorology, University of Utah
Rich Southwick	Air Quality	B.S. Natural Resources Management, Syracuse University
Joe Peterson	Air Quality	B.S. Environmental Engineering, Montana Tech of the University of Montana
Hal Robbins	Air Quality	M.S. Environmental Sciences, University of Montana B.S. Physics, University of Montana

Project Proponent Baseline Information

Joe Dickey	Project Manager
Steven Wade Browning, Kaleczyc, Berry and Hoven, P.C.	Attorney
Tim Krause Sargent and Lundy	Design, Engineering, Environmental Impacts, Air Pollution Control
Bill Stenzel Sargent and Lundy	Equip.Noise levels or plant design
Ken Snell	Permitting/Enviro Issues
George Kujawa Sargent and Lundy	Visual
Dan Hadley Mission Engineering, Inc.	Water Resources, Geology
Diane Lorenzen Lorenzen Engineering, Inc.	Air Quality
Pat Farmer Westech Environmental Services	Vegetation, Soils, Wildlife & Aquatics
Dean Culwell Westech Environmental Services	Vegetation, Soils, Wildlife & Aquatics

Tim Watts Watts and Associates	Socioeconomics
John Mangus Watts and Associates	Socioeconomics
Dr. Paul Polzin Watts and Associates	Socioeconomics
Lynelle Peterson Ethnoscience, Inc.	Cultural Resources/Archaeology
John Pouley Ethnoscience, Inc.	Cultural Resources/Archaeology
Sean Connolly Big Sky Acoustics	Noise
Rebecca Hanna Ethnoscience, Inc.	Paleontology
McVehil-Monnett Associates	CALPUFF

CHAPTER 7 REFERENCES

References cited throughout the document

Bull Mountain Development Company, LLC. May 2002a. Supplemental Environmental Impact Statement Support Document

Meridian Minerals Company. 1989-1992. Meridian Minerals Company Bull Mountains Mine No. 1 permit application, Musselshell County, Montana. 14 vols. Submitted to the Montana Department of State Lands and the Office of Surface Mining Reclamation and Enforcement.

Montana Department of Natural Resources and Conservation (DNRC), Trust Land Management Division, 2002. Bull Mountain Coal Railroad Spur Checklist EA

Montana Department of State Lands (MDSL). 1992. Final Environmental Impact Statement. Meridian Minerals Company Bull Mountains Mine No. 1, Musselshell and Yellowstone Counties, Montana. MDSL, Helena.

Western Area Power Administration (WAPA), 2002. Upper Great Plains Region, Transmission Planning, July 2002.

Western Electricity Coordinating Council (WECC). 2002. 10-Year Coordinated Plan Summary; Planning and Operation for Electric System Reliability.

Air Resources

Administrative Rules of Montana, Title 75, Chapter 1, Environmental Policy and Protection Generally, 2001.

Administrative Rules of Montana, Title 17, Chapter 8, Sub-chapter 2, Ambient Air Quality, September 30, 1996.

Administrative Rules of Montana, Title 17, Chapter 8, Sub-chapter 8, Prevention of Significant Deterioration of Air Quality, September 30, 1996.

Administrative Rules of Montana, Title 17, Chapter 8, Sub-chapter 11, Visibility Impact Assessment, September 30, 1996.

Billings Logan Airport data in SAMSON format. Information obtained from the World Wide Web. <<http://www.WebMET.com>>.

Bull Mountain Development Company, LLC., Application for Montana Air Quality Preconstruction and Prevention of Significant Deterioration (PSD) Permit and Application for Montana Title V Operating Permit. January 2002b.

_____. Letter to Dan Walsh, Montana DEQ. Roundup Power Project Visibility Analysis. October 25, 2002c.

- _____. Letter to Dan Walsh, Montana DEQ. Roundup Power Project Visibility Analysis. October 21, 2002d.
- _____. Submittal to Dan Walsh, Montana DEQ, Section 5.0 Cumulative Visibility Analysis, November 7, 2002e.
- _____. Roundup Power Project Cumulative Air Quality Modeling Report, submitted to DEQ on October 25, 2002f.
- Federal Register, Volume 65, No. 245, December 20, 2000, pp. 79825-79831.
- Intergovernmental Panel on Climate Change (IPCC), 2002 ,<http://www.ipcc.ch>
- Lorenzen, Diane R. P.E., Lorenzen Engineering, Inc. Letter to Dan Walsh, Montana DEQ. April 16, 2002a.
- _____. Lorenzen Engineering, Inc. Memo to Dan Walsh, Montana DEQ. Roundup Power CALPUFF Modeling. October 18, 2002b.
- McVehil-Monnett Associates. 2002. Ambient Air Quality Monitoring Data Reports for the Roundup Power Plant Project Near Roundup, Montana . January 1 —July 15.
- Montana Department of Environmental Quality. 2002. Air & Waste Management Bureau. Preliminary Determination on Permit Application, Permit #3182-00. August 12.
- National Oceanic & Atmospheric Administration (NOAA). Western Regional Climate Center. 2002. Information obtained from the World Wide Web.
<<http://lwf.ncdc.noaa.gov/oa/ncdc.html>>
- National Park Service and US Fish and Wildlife Service. 2002a Guidance on Nitrogen and Sulfur Deposition Analysis Thresholds..
- National Park Service and US Fish Wildlife Service letter ^{to Dan Walsh,} Montana ^{DEQ,} Nov. 6, 2002^b
- National Park Service, United States Forest Service and US Fish and Wildlife Service. Federal Land Managers Air Quality Related Values Workgroup (FLAG) – Phase I Report (12/2000).
- Srivastava, Ravi K., Charles B. Sedman and James D. Kilgore. Preliminary Estimates of Performance and Cost of Mercury Control Technology Applications on Electric Utility Boilers. Journal of the Air and Waste Management Association. October, 2001.
- Story, Mark T., Region 1 Forest Service, Gallatin National Forest. Letter to Montana DEQ, Review of Roundup and Hardin Coal Burning Power Plant PSD Permits. June 6, 2002.
- Title 40 Code of Federal Regulations Part 50 National Primary and Secondary Ambient Air Quality Standards, Revised as of July 1, 2001.
- United States Environmental Protection Agency. 2002. Office of Air and Radiation, AIRsData online database. Information obtained from the World Wide Web.
<<http://www.epa.gov/air/data/>>.
- _____. 2000. EPA to Regulate Mercury and Other Air Toxics Emissions from Coal- and Oil-Fired Power Plants. Information obtained December 14, 2000 from the World Wide Web.
<<http://www.epa.gov/ttn/uatw/combust/utiltox/utoxpg.html>>.
- _____. 1999. Introduction to Estimating Greenhouse Gas Emissions.

- _____. 1998. Compilation of Air Pollution Emission Factors (AP-42).
- _____. 1990. Office of Air Quality Planning and Standards. New Source Review Workshop Manual, Draft.
- _____. 1980. Smith, A.E. and J.B. Levenson. A Screening Procedure of Air Pollution Sources on Plants, Soils, and Animals. EPA 450/2-81-078.
- Wade, Steven T., Browning, Kaleczyc, Berry & Hoven. 2002a. Letter to Dan Walsh, Montana DEQ, Incompleteness Response, March 5.
- _____. 2002b. Browning, Kaleczyc, Berry & Hoven Letter to Dan Walsh, Montana DEQ. Revised CALPUFF Model Results for Roundup Project. April 12.
- Western Area Power Administration (WAPA), 2002

Water Resources

- Feltis, R. D. 1993. Hydrogeology of the Madison Group in Central Montana, Energy and Minerals of Central Montana. Billings Geological Society.
- _____. 1984, Roundup 1° x 2° quadrangle, central Montana: Structure contour (configuration) map of the top of the Madison Group: Montana Bureau of Mines and Geology Geologic Map 35, scale 1:250,000.
- Lee Techni-Coal. 1993. Proposed Bull Mountains Mine No. 1 Deep Water Well, Meridian Minerals Company.
- Montana Bureau of Mines and Geology (MBMG), Ground-Water Information Center, Montana Tech of The University of Montana. Information obtained from the World Wide Web. <<http://bogc.dnrc.state.mt.us/OnlineData.htm>>.
- Montana Bureau of Oil & Gas Conservation (MBOGC). On-Line Oil and Gas Information obtained from the World Wide Web. <<http://bogc.dnrc.state.mt.us/OnlineData.htm>>.
- National Oceanic & Atmospheric Administration (NOAA). Western Regional Climate Center. 2002. Information obtained from the World Wide Web. <<http://lwf.ncdc.noaa.gov/oa/ncdc.html>> Earth Resources

Earth Resources

- Balster, C., Editor. 1971. "Catalogue of Stratigraphic Names for Montana." Montana Bureau of Mines and Geology. Special Publication 54.
- Feltis, R.D., 1984, Roundup 1° x 2° quadrangle, central Montana: Structure contour (configuration) map of the top of the Madison Group: Montana Bureau of Mines and Geology Geologic Map 35, scale 1:250,000.
- Lee Techni-Coal. 1991. Bull Mountains Mine No. 1 Soil Survey, prepared for Meridian Minerals Company, Billings, Montana.

- Meshnick, J.C., F.T. Miller, H. Smith, L. Gray, and W.C. Bourne. 1972. Soil Survey of Yellowstone County, Montana, USDA – Soil Conservation Service and Bureau of Indian Affairs, in cooperation with Montana Agricultural Experiment Station. Washington, D.C.
- Montagne, C, L.C. Munn, G.A. Neilson, J.W. Rogers, and H.E. Hunter. 1982. Soils of Montana, Montana Agricultural Experiment Station Bulletin 744. Montana State University. Bozeman, Montana.
- Montana Bureau of Oil & Gas Conservation (MBOGC). On-Line Oil and Gas Information obtained from the World Wide Web. <<http://bogc.dnrc.state.mt.us/OnlineData.htm>>.
- Stricker, G.D. 1999. Bull Mountains Basin, Montana, Chapter SM in U.S. Geological Survey Professional Paper 1625-A.
- US Department of Agriculture. Information obtained from the Department of Natural Resources web site for Montana county soil data. <<http://nris.state.mt.us/nrcs/soils/datapage.html>>.
- Wilde, E., and K. Porter. 2000. Geologic Map of the Roundup 30° x 60° Quadrangle, Central Montana, Montana Bureau of mines and Geology Open File Report MBMG 404.

Botanical and Wetland Resources

- Duncan, C. 2001. The Montana Weed Management Plan. Helena, Montana.
- EPCOR. 2001. Genesee Generating Station Phase 3 Integrated Application – Section 4.7. Terrestrial and wetland vegetation. Application to Alberta Energy and Utilities Board and Alberta Environment.
- Gordon, C.C., P.C. Tourangeau, and P.M. Rice. 1978. Investigation of the impact of coal-fired power plant emissions upon the disease/health/growth characteristics of ponderosa pine-skunkbush ecosystems and grassland ecosystems in southeastern Montana. In: The Bioenvironmental Impact of a Coal-Fired Power Plant. Third Interim Report, Colstrip, Montana (ed. By E.R. Preston and R.A. Lewis, p 65-140). Corvallis Environ. Res. Lab. US/EPA, Corvallis, Oregon.
- _____. 1979. Foliar pathologies of ponderosa pine near Colstrip. In: The Bioenvironmental Impact of a Coal-Fired Power Plant. Fourth Interim Report, Colstrip, Montana (ed. By E.R. Preston and T.L. Gullett, p 107-131). Corvallis Environ. Res. Lab. US/EPA, Corvallis, Oregon.
- Grodzinski, W. and T.P. Yorks. 1981. Species And Ecosystem Level Bioindicators Of Airborn Pollution: An Analysis Of Two Major Studies. *Water, Air and Soil Pollution* 16:33-53.
- Miller, Martin. Montana Natural Heritage Program. Personal communication, October 9, 2002a.
- Montana Natural Heritage Program. 2002b. Letter to Pat Farmer, Western Technology and Engineering, Inc. February 4, 2002.
- Munshower, F.F., B.W. Sindelar, and D.R. Newman. 1975. The Effects of Stack Emissions on the Range Resource in the Vicinity of Colstrip, Montana. Progress Report 1972-74. Montana Agr. Exp. Station and Montana State Univ., Bozeman, Montana. 73 pp.

- Munshower, F.F., and E.J. Deput. 1976. The Effects of Stack Emissions on the Range Resource in the Vicinity of Colstrip, Montana. Progress Report 1975. Montana Agr. Exp. Station and Montana State Univ., Bozeman, Montana. 112 pp.
- Ring, T. Montana Department of Environmental Quality. Personal communication. February 6, 2001.
- Taylor, J.E., W.C. Leininger, and M.W. Hoard. 1980. Plant Community Monitoring in the Vicinity of Colstrip, Montana. In: The bioenvironmental impacts of a coal-fired power plant. Fifth Interim Report. Colstrip, Montana (ed. E.M. Preston and D.W. O'Guinn, p. 55-71). Corvallis Environ. Res. Lab., US/EPA, Corvallis, Oregon. 932 p.
- United States Department of the Interior, Geological Survey. 1979. Environmental statement – proposed Colstrip project. Rosebud County, Montana. Vol. 1 and 2.
- Western Technology and Engineering, Inc. 1991. Supplemental Vegetation information, Bull Mountains Mine no. 1. Technical report prepared for Meridian Minerals Company by Western Technology and Engineering, Inc., Helena, Montana.

Wildlife Resources

- Butts, T.W. 1997. Mountain, Inc. Wildlife Monitoring, Bull Mountains Mine No. 1, 1996. Tech. Rep. By Western Technology and Engineering, Inc. for Mountain Inc., Roundup.
- Holton, G.D. and H.E. Johnson. 1996. A Field Guide to Montana Fishes. Montana Department of Fish, Wildlife and Parks, Helena, Montana.
- Montana Department of Fish, Wildlife and Parks. 2001. Montana Rivers Information System (MRIS) database. Information obtained from the World Wide Web. <<http://nris.state.mt.us/wis/mris.1.html>>.
- Montana Natural Heritage Program. 2002a. Species of Special Concern within a 10-mile Radius of the Proposed Roundup Power Project. Unpublished. Report dated January 31, 2002.
- Moore, Orville. Moore Quality Flying, Roundup. Personal communication. March 27, 2002.
- Newell, Jay October 15, 2002. Area wildlife biologist, Montana Department of Fish, Wildlife, and Parks. Personal communication.
- Western Technology and Engineering, Inc. (WESTECH). 1993. Meridian Wildlife Monitoring, Bull Mountains Mine No. 1, 1992. Tech. Rep. for Meridian Minerals Co., Billings.

Fisheries and Aquatic Resources

- Holton, G.D. and H.E. Johnson. 1996. A Field Guide to Montana Fishes. Montana Department of Fish, Wildlife and Parks, Helena, Montana.
- Montana Department of Fish, Wildlife and Parks. 2001. Montana Rivers Information System (MRIS) database. Information obtained from the World Wide Web. <<http://nris.state.mt.us/wis/mris.1.html>>.

- Montana Natural Heritage Program. 2002a. Species of special concern within a 10-mile radius of the proposed Roundup Power Project. Unpublished. Report dated January 31, 2002.
- Moore, Orville. March 27, 2002. Owner/pilot, Moore Quality Flying, Roundup. Personal communication.
- Newell, Jay. October 15, 2002. Area wildlife biologist, Montana Department of Fish, Wildlife, and Parks. Personal communication.
- Western Technology and Engineering, Inc. (WESTECH). 1993. Meridian wildlife monitoring, Bull Mountains Mine No. 1, 1992. Tech. Rep. for Meridian Minerals Co., Billings.

Cultural Resources

- Ames Construction, Bull Mountains Land Company, LLC. Inc. 2002. A Programmatic Work Plan for Cultural Resource Studies and an Archaeological Treatment Plan for the Bull Mountains Railroad, Yellowstone and Musselshell Counties, Montana. Prepared by Metcalf Archaeological Consultants, Inc. Eagle, Colorado.
- Bohman, Robert, 2002. Personal Communication, October 9, 2002. Montana Department of Environmental Quality, Permitting/Compliance Division, Industrial and Energy Minerals Bureau. Helena, MT.
- Letter from M. Metcalf to L. Boteilho, Ames Construction, Inc. West Valley City, Utah. October 18, 2002b.
- Montana Department of State Lands 1991. A Survey of Homesteading and Prehistoric Land Use, Bull Mountains, Montana. Report Prepared by Tetra Tech, Inc.
- Pool, K.J. 1991. Meridian Minerals Proposed Broadview to Bull Mountains Railroad Corridor, Musselshell and Yellowstone Counties, Montana: A Class III Cultural Resources Inventory of Corridor Realignment. Prepared for Meridian Minerals Company, Englewood, Colorado by Metcalf Archaeological Consultants, Inc. Eagle, Colorado.
- Pouley, John O. 2002. Archaeological Investigative Cultural Resource Survey for the Bull Mountains Power Project, Musselshell County, Montana. Prepared for Mission Engineering, Inc. Billings, Mt. Prepared by Ethnoscience, Inc. Billings, MT.
- Tetra Tech Incorporated. 1991. A Survey of Homesteading and Prehistoric Land Use, Bull Mountains, Montana. Report prepared for Montana Department of Lands, Billings, Montana, by Tetra Tech, Inc. Helena, MT
- Rood, R.J. 1990. Results of a Class I and Class II Archaeological Survey for Meridian Minerals Company Bull Mountains Mine No. 1, Bull Mountains, Montana. Prepared for Greystone Development Consultants, Englewood, Colorado by Metcalf Archaeological Consultants, Inc. Eagle, Colorado.
- Warhank, Josef, 2002. Personal Communication, October 1 and 7, 2002. Historian/Compliance Officer, Montana State Historic Preservation Office, Montana Historical Society. Helena, MT.

Visual Resources

- Beaudry, Candi. Yellowstone County Montana, Planning Department Personal communication. October 9 and 16, 2002.
- Dames and Moore. 1992. Southwest Intertie Project Technical Report, Volume III, Human Environment.
- Danielson, Kirby. Musselshell County, Montana. Personal communication. October 3 and 9, 2002.
- Fenneman, N.M. 1931. Physiography of the Western United States. McGraw Hill, Book Company Inc. New York and London.
- Intermountain Planners, Inc. 1973. Comprehensive Plan, Musselshell County 1973-1993.
- Jones and Jones. 1976. "Measuring the Visibility of High Voltage Transmission Facilities in the Pacific Northwest."
- Musselshell County. 2002. Musselshell County rural addressing data
- Riley, James. 2001. Aerospace Management Specialist, Federal Aeronautics Administration, Seattle. Personal Communication with Nancy Johnson, DEQ, Regarding Filing of Federal Aviation Administration Form 7460-1.
- United States Department of the Interior, Bureau of Land Management. 1984. Bureau of Land Management Manual 8400 – Visual Resource Management April 5, 1984.
- _____. 1986. Bureau of Land Management Manual H-8410-1 Visual Resource Inventory 11/17/86.
- _____. 1986. Bureau of Land Management Manual H-8431-1 Visual Resource Contrast Rating 11/17/86.
- Yellowstone County Planning Department. 1990. Yellowstone County Comprehensive Plan.

Noise

- Acoustical Society of America (ASA), edited by Cyril M. Harris. 1998. The Handbook of Acoustical Measurements and Noise Control. 3rd Edition.
- American Society of Testing and Materials (ASTM). 1984. Standard E1014-84. Standard Guide for Measurement of Outdoor A-Weighted Sound Levels.
- Beranek, Leo and Istvan Ver (ed.). 1992. Noise and Vibration Control Engineering, Principles and Applications. John Wiley & Sons, Inc.
- Crocker, Malcolm J. (ed.). 1997. The Encyclopedia of Acoustics. John Wiley & Sons, Inc.
- Danielson, Kirby. 2002. Planning Department. Personal communication.
- Edison Electric Institute (EEI). 1983. Electric Power Plant Environmental Noise Guide. Volumes 1 and 2. 2nd Edition.
- Egan, M. David (ed.). 1988. Architectural Acoustics. McGraw-Hill Publishing Company.

- Elliott, Thomas C., Chen, Kao, Swanekamp, Robert C. 1997. Standard Handbook of Powerplant Engineering. 2nd Edition. McGraw-Hill Publishing Company.
- IEEE. 2000. Guide for Sound Level Abatement and Determination for Liquid-Immersed Power Transformers and Shunt Reactors Rated Over 500kVA. IEEE Standard C57.136-2000.
- _____. 1981. "Formulas for Predicting Audible Noise From Overhead High Voltage AC and DC Lines." Transactions on Power Apparatus and Systems. Vol. PAS-100, No. VL Chartier and RD Stearns.
- International Organization for Standardization (ISO). 1996. Standard 9613-2. Attenuation of Sound During Propagation Outdoors. Part 2: General Method of Calculation.
- Lord, Harold W., William S. Gatley, and Harold A. Evensen. 1987. Noise Control For Engineers. Krieger Publishing Company. Malabar, Florida.
- POWER Engineers, Inc. 2002. Map verifying sensitive receptors. Updated October 11, 2002.
- Sargent & Lundy, LLC. 2002a. Re: E-mail communications from Tim Krause regarding noise control commitments. May 7, 2002.
- _____. 2002b. Roundup Power Project Preliminary Equipment List and information. E-mail communications by Bill Stenzel and Ed Giermak. January 24 and 25, 2002.
- _____. 2002c. Preliminary forced-draft, primary-air, and induced-draft fan noise levels E-mail communications by Bill Stenzel. March 13, 2002.
- _____. 2002d. Re: E-mail communications, comments and information provided by Bill Stenzel, regarding construction methods, schedule, operations, and lime delivery. April 12, 2002.
- _____. Bill Stenzel. Personal communication. February 19, 2002e.
- State of Montana, Legislative Services Division. 1999. Re: Facsimile transmission of the Administrative Rules of Montana (ARM) Chapter 30, Nuisances, Sections 27-30-101 and 27-30-102.
- Tallon, Brendan. Personal communication. October 17, 2002.
- United States Department of Transportation (DOT). Federal Highway Administration. 1995a. Highway Traffic Noise Analysis and Abatement; Policy and Guidance.
- _____. Federal Transit Administration. 1995b. Transit Noise and Vibration Impact Assessment.
- United States Environmental Protection Agency (EPA). 1974. Information on Levels of Environmental Noise Requisite to Protect the Public Health and Welfare with an Adequate Margin of Safety. EPA 550/9-74-004.
- United States Geological Survey (USGS). 1980. 7.5-Minute Topographic Map. Signal Mountain Montana.

Land Use

- Beaudry, Candi. Yellowstone County Montana, Planning Department. Personal communication. October 9 and 16, 2002.
- Brandenburg, Gary. Montana Department of Natural Resources and Conservation, Southern Land Office. Personal communication. October 4 and 16, 2002.
- Charlton, Cindy. United States Department of Agriculture, Roundup Service Center, Farm Service Agency. Personal communication. October 9, 2002.
- Cumin, Cal. Yellowstone County Park Board, Personal communication. October 22, 2002.
- Danielson, Kirby. Musselshell County, Montana. Personal communication. October 3 and 9, 2002
- Gaglia, Jackie. United States Department of Agriculture, Billings Service Center, Farm Service Agency. Personal communication. October 9, 21 and 22, 2002.
- Hanify, Ken. United States Department of the Interior, Bureau of Land Management, Billings Field Office. Personal communication. October 22, 2002.
- Hinck, Laura. Montana Department of Agriculture. Personal communication. October 22, 2002.
- Intermountain Planners, Inc. 1973. Comprehensive Plan, Musselshell County 1973-1993.
- Miller, Martin. Montana Natural Heritage Program. Personal communication. October 4, 2002.
- Montague, Chris. Montana Land Reliance. Personal communication. October 3, 2002.
- Montana Department of Agriculture. October 2001. Montana Agricultural Statistics.
- Musselshell County. 2002. Fact Sheet: Facts At-A-Glance.
- State of Montana, Department of Environmental Quality, Permitting and Compliance Division. 2001. Draft Environmental Impact Statement. Silver Bow Generation Project.
- United States Department of Agriculture. Billings Service Center, Farm Service Agency. Yellowstone County cropland and Conservation Reserve Program land maps.
- _____. Farm Service Agency. Fact Sheet – Electronic Edition. October 1999 Conservation Reserve Program. Information obtained from the World Wide Web<<http://www.fsa.usda.gov/pas/publications/facts/html/crp99.htm>>
- _____. Roundup Service Center, Farm Service Agency. Musselshell County cropland and Conservation Reserve Program land maps.
- Wegmann, Bob. United States Department of Agriculture. Personal communication. October 3 and 9, 2002.
- Wheeler, Jan. Montana Department of Natural Resources and Conservation, Southern Land Office. Personal communication. October 22, 2002.
- Williams, Burt. The Nature Conservancy, Montana Field Office Personal communication. October 22, 2002a.

_____. The Nature Conservancy, Montana Field Office Personal communication October 3, 2002b.

Yellowstone County Planning Department. 1990. Yellowstone County Comprehensive Plan

Socioeconomics

Cortese, Charles F., and Bernie Jones. 1977. "Alcoholism and Suicidal Behavior. The Sociological Analysis of Boom Towns." *Western Sociological Review*. 8 (1): 75-90.

DesJarlais, Deloris. Musselshell County Mental Health Center. Personal communication. January 28, 2002

Gable, Pam. Musselshell County Social Worker. Personal communication. January 23, 2002.

Hardt, Mark D. 1994. Robbery and Stress Related Mortality. *Boom and Bust: A Comparison of Social Impacts on Oil Producing Communities*.

Jonutis, Stan. Montana Department of Transportation, Billings Division. Personal communication. October 30, 2002

Lapping, Mark B., Thomas L. Daniels, and John W. Keller. 1989. *Rural Planning and Development in the United States*.

McIver, Dave. Hospital Administrator Roundup Memorial Hospital. Personal communication. January 18, 2002

Mercardo, Rosalie, dispatcher; Mark Shoup, Highway Patrol; and Chuck Poulos, Commissary Manager. Personal communication. January 22, 2002.

Moen, Elizabeth. 1980. "Social Problems in Energy Boom Towns and the Role of Women in their Prevention and Mitigation." *The Boom Town: Problems and Promises in the Energy Vortex*.

Murdock, Steven H., Larry Leistriz, and Eldon C. Schriener. 1980. *Migration and Energy Developments: Implications for Rural Areas in the Great Plains*. David Brown and John M Wardwell, eds. "New Directions In Urban-Rural Migration." Academic Press.

Solberg, Ron. Director of Ambulance Services, Musselshell County Ambulance Service. Personal communication. January 22, 2002.

Thomas, Gary. January 22, 2002. Waste Water Manager. City of Roundup. Personal communication.

United States Bureau of the Census. 2000. *Census of Population*. Information obtained from the World Wide Web. <www.census.gov>.

_____. 1997. *Census of Governments*. Information obtained from the World Wide Web. <www.census.gov>.

United States Bureau of Economic Analysis. *Regional Economic Information System (REIS)*. 2001.

Whitman, John. Facility Manager BFI. Personal communication. March 13, 2002.

CHAPTER 8 ACRONYMS AND GLOSSARY

ACSR – Aluminum conductor, steel reinforced.

AQRV - air-quality-related value.

ANSI – American National Standards Institute.

ASME – American Society of Mechanical Engineers.

Adverse Impact on Visibility - Visibility impairment which interferes with the management, protection, preservation, or enjoyment of a visitor's visual experience of a Federal Class I or Class II area. This determination must be made on a case-by-case basis taking into account the geographic extent, intensity, duration, frequency and time of visibility impairments, and how these factors correlate with (1) times of visitor use of the Class I area, and (2) the frequency and timing of natural conditions that reduce visibility. This term does not include effects on integral vistas. [40 CFR 51.301(a)]

Air-Cooled Condenser - Air-cooled steam condensers provide low turbine back-pressure and deaerate the condensate in a steam turbine. The heat rejected by the steam is absorbed in the form of a sensible heat gain in the ambient air.

Air Pollution – Dust, fumes, smoke, other particulate mater, vapor, gas odorous substance or any combination of these.

Acid Rain – Precipitation which contains carbonic acid, nitric acid, or sulfuric acid in solution. The source of these acids may be traced to the combustion of fossil fuels.

Alluvial – Composed of alluvium or deposited by a stream or running water.

Alluvium – A general term for all deposits resulting from the operations of modern rivers and creeks, including the sediments laid down in riverbeds, floodplains, and fans at the foot of mountain slopes.

Ambient Air Quality Standard – An established concentration, exposure time, and frequency of occurrence of air contaminant(s) in the ambient air that shall not be exceeded.

Ambient Level – The existing level of air pollutants, noise, or other environmental factors used to describe background conditions(i.e., conditions before a project is implemented).

Anticline – A configuration of folded, stratified rocks in which rocks dip in two directions away from a crest, as principal rafters of a common gable roof dip away from ridgepole.

Apiary – A place where bees are kept.

Aquifer – Rock of sediment in a formation, or group of formations, or part of that formation that is saturated and sufficiently permeable to transmit economic quantities of water to wells and springs.

Artesian flow – Discharge of water from a well, spring, or aquifer by hydrostatic pressure.

BPA - Bonneville Power Administration.

BTU – British thermal unit. A measure of the energy required to raise the temperature of one pound of water by one degree Fahrenheit.

Baghouse - Also referred to as a fabric filter, baghouses separate particulates from a flue gas stream by filtration of the gas through a woven or felted fabric that has been sewn into a bag. Collection efficiencies can be expected to be 99.8% or greater of inlet dust loading.

Benthic – Of, relating to, or occurring at the bottom of a body of water.

Best Available Control Technology (BACT) – An EPA requirement that all major new plants use to limit their emissions. Used to prevent significant deterioration (PSD) of air quality in areas that were already in attainment of the National Air Quality Control Standards.

Best Management Practices (BMP) – A practice or combination of practices that are determined to be the most effective and practicable (including technological, economic, and institutional considerations) means of controlling point and nonpoint pollutants at levels compatible with environmental quality goals.

Big Game – Those species of large mammals normally managed as a sport hunting resource.

Bituminous – Type of coal with carbon content from 45% to 86% and heat value of 10, 500 to 15,500 BTUs-per-pound; most plentiful form of coal in U.S.; used primarily to generate electricity and make coke for steel.

CAA - Clean Air Act.

CAAA - Clean Air Act Amendments.

CCD - County Census Division.

CFC – chlorofluorocarbon.

CFR - Code of Federal Regulations.

CO - Carbon monoxide.

CRIS - Cultural Resource Information System

Cairn – A pile of rocks of prehistoric or historic origin that may have had a variety of functions, such as a monument, a marker, or a burial site.

Carbonic Acid/Carbon Dioxide – Coal contains carbon, which converts to a gas upon burning. When carbon dioxide combines with atmospheric water, it forms carbonic acid, which is absorbed as a nutrient by plants and trees.

Chemical Cleaning – Any pre-combustion cleaning technique that creates a chemical reaction, which changes the molecular form of organic sulfur in order for the sulfur to be easily separated and removed.

Circulating Fluidized Bed Combustion (CFBC) – Circulating fluidized bed combustion is a clean coal technology process that produces a mixture of coal and limestone in a liquid state by vertically moving air. The process effectively removes sulfur from coal, thus reducing sulfur dioxide emissions Also tends to reduce the formation of nitrogen oxide emissions.

Clinker – Thermally metamorphosed, fine-grained sedimentary rocks created by naturally burned coal beds. Often reddish brown to purple, brittle, with high porosity.

Coal Seam – A deposit of coal.

Conservation Reserve Program – A voluntary program that offers annual rental payments, incentive payments for certain activities, and cost-share assistance to establish approved cover on eligible cropland. The program encourages farmers to plant long-term resource conserving covers to improve soil, water, and wildlife resources. The Commodity Credit Corporation (CCC) makes available assistance in an amount equal to not more than 50 percent of the participant's costs in establishing approved practices. Contract duration is between 10 and 15 years. The CRP is administered by the CCC through the Farm Service Agency (FSA).

Conveyor – A continuous moving belt that transports large volumes of material.

Cultural Resources – Sites, buildings, structures, districts, landscapes, or objects that are important to a culture or community for scientific, traditional, religious, or other reasons. Cultural resources can be divided into three major categories: archaeological resources, architectural resources, and Traditional Cultural Properties.

dB(A) – Stands for A weighted decibels. This decibel scale is used to approximate the way human hearing responds more to some frequencies than to others.

DEIS - Draft Environmental Impact Statement

DEQ - Department of Environmental Quality

Decibel (dB) – A unit of measure for sound.

Dip – The angle at which a rock surface is inclined from the horizontal.

Dry Scrubber - Dry scrubbing involves spraying an aqueous sorbent into a reactor vessel so that the droplets dry as they contact the hot flue gas. The SO₂ removal reaction occurs during the drying process. A dry scrubber is usually coupled with a particulates removal device to separate the dry powder produced in the reactor, and fly ash, from the flue gas.

EC - electrical conductivity.

EPA - (United States) Environmental Protection Agency.

Electrostatic Precipitator (ESP) – An electrical device for removing small particles such as fly ash from combustion gases before release from a power plant's stack.

Emission – The release of air contaminants into the ambient air.

Ephemeral Drainage – A stream or stream segment that flows only briefly in response to local precipitation and has no base flow.

FD - Forced draft.

FEIS - Final Environmental Impact Statement.

FGR - Flue gas recirculation.

Flue Gas Desulfurization (FGD) – A clean coal technology consisting of a device fitted between a power plant's boiler and its smokestack. The device removes sulfur dioxide from flue

gases flowing up the stack during the post-combustion stage of coal churning. See "SCRUBBER".

Flue Gas Recirculation - A NO_x reduction process which reduces oxygen concentration and combustion temperatures by recirculating some of the flue gas to the furnace without increasing the total net gas mass flow.

Fluidized Bed Combustion – A clean coal technology process that removes sulfur from coal during combustion. In a fluidized bed boiler, crushed coal and limestone are suspended in the boiler by an upward stream of hot air. The coal is burned in this ebullient, liquid-like mixture, hence the name "fluidized." As the coal burns, sulfur gases from coal combine with limestone to form a solid compound that is recovered with ash.

Fluvial – Produced from the action of a river or stream. Refers to material transported by, suspended in, or deposited by river or stream action.

Fly Ash – The finely divided, inert particles of ash in flue gases arising from the combustion of fuel.

Formation – A body of rock of sufficient lateral extent and distinctive characteristics that allow geologists to map, describe, and name it.

Fossil Fuels – Naturally occurring fuels of an organic nature, such as coal, crude oil, and natural gas.

Fugitive Dust – A particulate emission made airborne by forces of wind, human activity, or both. Unpaved roads, construction sites, and tilled land are examples of areas that generate fugitive dust.

GVW – Gross vehicle weight.

GWP - Global warming potential.

Glaciated – Subjected to glacial action; also: showing the effects of glacial action.

Greenhouse Effect – A warming of the earth produced by the presence of certain gases in the atmosphere.

Greenhouse gases – A series of naturally-occurring gases capable of adsorbing heat in the atmosphere (e.g. carbon dioxide, methane, ozone, nitrous oxide). There are also unnatural greenhouse gases (e.g. chlorofluorocarbons).

Groundwater – Water found beneath the Earth's surface where all empty space in the rock is completely filled with water.

Group – A major rock-stratigraphic unit next higher in rank than a formation consisting wholly of two or more contiguous or associated formations having significant common lithologic features.

HAP - Hazardous air pollutant.

HDPE – high density polyethylene

HCFC – Hydrochlorofluorocarbon.

HFC – Hydrofluorocarbon.

High Sulfur – Coal that naturally contains a large amount of sulfur that converts into sulfur dioxide upon burning.

Historic – The period of time following the common use of written records in a specific area. In Montana, this term generally refers to the period after Euroamericans came to the region.

Hydrostratigraphy – Identification of rock formations based on their ability to transmit water.

ID - Induced draft.

IPCC - Intergovernmental Panel on Climate Change.

ISC - Industrial Source Complex.

ISO - International Organization for Standardization.

Integrated Gasification Combined Cycle - Coal gasification is a process that converts coal from a solid to a gaseous fuel through partial oxidation. Once the fuel is in a gaseous state contaminants, such as ash and sulfur compounds, may be removed by established techniques. The cleaned gas may then be combusted in a combined cycle (combustion turbine, heat recovery steam generator, steam turbine) power system to produce electricity.

Intermittent Stream – A stream that flows in a well-defined channel in response to precipitation and is dry for part of the year.

Km – kilometer. Equivalent to 0.621 miles

L_{dn} - Day-night average noise level.

LDPE – low density polyethylene

Lacustrine – Of, relating to, formed in, living in, or growing in lakes.

Lithic – Of, relating to, or being a stone tool.

Lithic Scatter – A prehistoric archaeological site consisting primarily of stone tools and the flakes resulting from stone tool manufacturing and use.

Longwall Mining – Mechanized technique used to “scrape” coal from a block several hundred feet wide.

Low-NO_x Burner (LNB) - Specially designed burners which minimize the formation of NO_x by reducing the oxidation of fuel-bound nitrogen and the formation of thermal NO_x through reduced oxygen combustion. This lean-burning reduces devolatilization of fuel-bound nitrogen and reduces flame temperature which reduces thermally formed NO_x.

MAAQS – Montana Ambient Air Quality Standards.

MACT – Maximum achievable control technology.

MDEQ – Montana Department of Environmental Quality.

MDFWP – Montana Department of Fish, Wildlife and Parks.

MDSL – Montana Department of State Lands.

MEPA – Montana Environmental Policy Act.

MPDES – Montana Pollutant Discharge Elimination System.

NAAQS - National Ambient Air Quality Standards.

NET – National Emission Trends.

NHPA – National Historic Preservation Act

NFPA – National Fire Protection Agency.

NMVOC – Non-methane volatile organic compound.

NSPS - New Source Performance Standards.

NTI - National Toxics Inventory.

NWS - National Weather Service.

National Acid Precipitation Assessment Program (NAPAP) – A 10-year, \$570 million federal effort that investigated and assessed the acid rain phenomenon from 1980 to 1990.

National Register of Historic Places (NRHP) – The Nation's official list of cultural resources worthy of preservation. Authorized under the National Historic Preservation Act of 1966, the National Register is part of a national program to coordinate and support public and private efforts to identify, evaluate, and protect our historic and archeological resources. The National Park Service administers the National Register.

Nitrogen Dioxide (NO₂) – A reddish brown gas that is a component of smog.

Nitrogen Oxides (NO_x) – A group of compounds containing varying proportions of nitrogen and oxygen.

Noxious Weeds – Exotic (non-native) species of plants that proliferate and reduce the value of land for agriculture, forestry, livestock, wildlife, or other beneficial uses.

OSHA - Occupational Safety and Health Administration

Overfire Air (OFA) - Relocated secondary air for a boiler combustion system. The air is diverted to ports which introduce it later in the combustion process. The majority of applications place the ports above (over) the burner zone in a furnace.

PA – Primary air.

PFC – Perfluorocarbon.

PM₁₀ - Particulate matter smaller than 10 microns in diameter.

PSD - Prevention of Significant Deterioration (of air quality)

Permeability – The ability of a rock or other material to allow water to flow through interconnected spaces. Permeable bedrock makes a good aquifer, a rock layer that yields water to wells.

Petroglyph – Cultural symbols, lines, or figures inscribed onto a rock surface by grinding, pecking or incising. The symbols may be prehistoric or historic.

Porosity – The ratio of the volume of the void spaces in a rock or sediment to the total volume of the rock or sediment.

Post-Combustion Cleaning – Cleaning coal emissions after combustion between the boiler and the smokestack.

Pre-Combustion Cleaning – Coal is cleaned by removing sulfur and mineral matter before combustion to reduce the emission of sulfur dioxide from combustion gases.

Prehistoric – The period of time before the use of written records in a specific area. In Montana this term usually refers to archaeological resources associated with Native Americans before contact with Euroamericans.

Pulverized Coal-Fired Boiler - Pulverized coal-fired boilers burn coal as a fine powder suspension (generally 90% <200 mesh) in an open furnace. This type of boiler is the dominant type used for coal-fired power plants today.

Pyrites - A form of iron sulfur compounds that have the formula FeS_2 . Found as a part of the ash in certain coals.

RAS – Remedial Action Schemes.

Reclamation – The process of restoring a surface mine site to its original contour, function, and appearance, thus “reclaiming” it.

Right-of-Way (ROW) – The right to pass over property owned by another. The strip of land over which facilities such as roadways, railroads, pipelines, or powerlines are built.

Rockshelter – A small overhang or cave used for shelter by prehistoric or historic people.

SO_x – Sulfur Oxides.

SO₂ - Sulfur dioxide.

Salmonid – Any of a family (Salmonidae) of elongate bony fishes (as a salmon or trout) that have the last three vertebrae upturned.

Scrubber – Any of several forms of chemical/physical devices that operate to remove sulfur compounds formed during coal combustion. These devices combine the sulfur in gaseous emissions with another chemical medium to form inert "sludge," which is removed for disposal or sold as a by-product.

Section 106 – A section of the National Historic Preservation Act of 1966 describing procedures for identifying, evaluating, and protecting cultural resources. The implementing regulations for Section 106 are in 36 CFR part 800.

Selective catalytic reduction (SCR) - A post-combustion NO_x reduction process which remove NO_x from flue gases by reaction with ammonia in the presence of a catalyst.

Selective non-catalytic reduction (SNCR) – A post-combustion NO_x reduction process wherein ammonia or other compounds such as urea are injected downstream of the combustion zone in a temperature region of 1400F to 2000F. If injected at the optimum temperature, NO_x is removed from the flue gas through reaction with the ammonia.

Slurry – A mixture of water and any of several finely crushed solids, especially cement, clay, or coal.

Special Status Species – Those species of plants or animals that have a protective status designated by a state or federal agency because of general or localized rarity or population decline.

State Historic Preservation Officer (SHPO) – The state official charged with overseeing the implementation of the Section 106 process.

Stoker Boiler - Mechanical stokers are boilers designed to feed fuel onto a grate where it burns with air passing up through it. The stoker is located within the furnace and is designed to remove the ash residue after combustion. Practical considerations limit stoker size and, consequently, the maximum steam generation rates.

Sulfur Dioxide Emission / Sulfuric Acid-Sulfate – Coal contains sulfur, which converts to gas upon burning. The sulfur dioxide gas combines with atmospheric water to form sulfuric acid/sulfate. Sulfate is a nutrient for trees and plants; however, in remote areas more sulfur is emitted than is needed by plants.

Sulfuric Acid Mist - H₂SO₄

Syncline – A configuration of folded, stratified rocks in which rocks dip downward from opposite directions to come together in a trough.

TSP - Total suspended particulates.

Traditional Cultural Property (TCP) – Resources associated with cultural practices and beliefs of a living community that are rooted in its history and are important in maintaining the continuing cultural identity of the community. In Montana, these are usually associated with modern Native Americans. Native American TCPs may include certain archaeological resources, such as cairns and petroglyphs; locations of important events; battlefields; sacred sites; and traditional hunting and gathering areas.

Tertiary – The tertiary period of systems of rocks.

Topsoil – Fertile soil or soil material, usually rich in organic matter, used to top dress disturbed areas. Topsoil is better suited to supporting plants than other materials.

USEPA - United States Environmental Protection Agency.

USGS – United States Geological Survey.

UTM – Universal Transverse Mercator.

Viewshed – The landscape that can be directly seen under favorable atmospheric conditions from a viewpoint or along a transportation corridor.

Visual Resources Management System (VRM) – The degree of acceptable visual change within a characteristic landscape. A class is based upon the physical and sociological characteristics of any given homogenous area as a management objective.

Volatile Organic Compound (VOC) – Any of several compounds of carbon that participate in atmospheric photochemical reactions, forming secondary pollutants.

WRCC - Western Regional Climate Center.

Wet Scrubber - A wet scrubber, used for removal of SO₂ from flue gases, contacts a sorbent slurry consisting of water mixed with lime, limestone, magnesium promoted lime, or sodium carbonate with the flue gas in a reactor vessel.

Wetlands – Areas that are inundated by surface or ground water with a frequency sufficient to support and under normal circumstances, does or would support a prevalence of vegetative or aquatic life that requires saturated or seasonally saturated soil conditions for growth and reproduction.

YNP - Yellowstone National Park.

APPENDIX A

Draft Air Quality Permit

AIR QUALITY PERMIT

Issued To: Roundup Power Project
P.O. Box 1697
Helena, Montana 59624

Permit: #3182-00
Application Complete: 07/22/02
Preliminary Determination Issued: 08/12/02
Department Decision Issued:
Permit Final:
AFS: #065-0003

An air quality permit, with conditions, is hereby granted to the Roundup Power Project (Roundup Power), pursuant to Sections 75-2-204 and 211 of the Montana Code Annotated (MCA), as amended, and Administrative Rules of Montana (ARM) 17.8.701, *et seq.*, as amended, for the following:

SECTION I: Permitted Facilities

A. Permitted Equipment

Roundup Power is proposing to construct and operate a nominal 780-megawatt (MW) pulverized coal (PC)-fired power plant. A complete list of the permitted equipment is contained in the permit analysis.

B. Plant Location

The proposed location for the Roundup Power coal-fired power plant is approximately 12 miles south-southeast of the town of Roundup, Montana. The site is located immediately east of U.S. Route 87, just east of Old Divide Road, and adjacent to the BMP Investments Incorporated proposed coal mine. The legal description of the site is the NW $\frac{1}{4}$ of the SE $\frac{1}{4}$ of Section 15, Township 6 North, Range 26 East in Musselshell County.

SECTION II. Conditions and Limitations

A. Operational and Emission Limitations

1. Roundup Power shall not cause or authorize emissions to be discharged into the outdoor atmosphere from any sources installed after November 23, 1968, that exhibit an opacity of 20% or greater averaged over 6 consecutive minutes (ARM 17.8.304).
2. Roundup Power shall not cause or authorize the use of any street, road, or parking lot without taking reasonable precautions to control emissions of airborne particulate matter (ARM 17.8.308).
3. Roundup Power shall treat all unpaved portions of the haul roads, access roads, parking lots, or general plant area with water and/or chemical dust suppressant as necessary to maintain compliance with the reasonable precautions limitation in Section II.A.2 (ARM 17.8.710).
4. The primary fuel feed rate for each of the two 390-MW PC boilers shall not exceed 1,646,880 tons of coal per rolling 12-month period (ARM 17.8.710).
5. The annual heat input to each of the 390-MW PC boilers shall not exceed 32,736,120 million British Thermal Units (mmBtu) per rolling 12-month period (ARM 17.8.710).

6. Oxides of nitrogen (NO_x) emissions from each of the two 390-MW PC boilers shall be controlled with the use of low-NO_x burners, overfire air, and selective catalytic reduction (SCR). NO_x emissions shall not exceed 261.6 lb/hr (0.07 lb/MMBtu) based on a rolling 30-day average (ARM 17.8.715).
7. Carbon monoxide (CO) emissions from each of the two 390-MW PC boilers shall be controlled by proper boiler design and operation. CO emissions shall not exceed 560.6 lb/hr (0.15 lb/MMBtu) (ARM 17.8.715).
8. Sulfur dioxide (SO₂) emissions from each of the two 390-MW PC boilers shall be controlled with the use of a dry flue gas desulfurization (FGD) system. SO₂ emissions shall not exceed 448.4 lb/hr (0.12 lb/MMBtu) based on a rolling 30-day average (ARM 17.8.715).
9. Particulate matter with an aerodynamic diameter less than 10 micrometers (PM₁₀) emissions from each of the two 390-MW PC boilers shall be controlled with the use of a fabric filter baghouse. PM₁₀ emissions shall not exceed 56.1 lb/hr (0.015 lb/MMBtu) (ARM 17.8.715).
10. Volatile Organic Compound (VOC) emissions from each of the two 390-MW PC boilers shall be controlled by proper boiler design and operation. VOC emissions shall not exceed 11.2 lb/hr (0.0030 lb/MMBtu) (ARM 17.8.715).
11. Sulfuric Acid (H₂SO₄) Mist emissions from each of the two 390-MW PC boilers shall be controlled with the use of dry FGD (ARM 17.8.715).
12. The stack height for each of the two 390-MW PC boilers shall, at a minimum, be maintained at 574 feet above ground level (ARM 17.8.710).
13. SO₂ emissions from each of the two auxiliary boilers shall not exceed 6.46 lb/hr (ARM 17.8.715).
14. NO_x emissions from each of the two auxiliary boilers shall not exceed 19.8 lb/hr (ARM 17.8.715).
15. CO emissions from each of the two auxiliary boilers shall not exceed 4.12 lb/hr (ARM 17.8.715).
16. The combined diesel consumption of the two auxiliary boilers shall be limited to 5,438,400 gallons per rolling 12-month period (ARM 17.8.710).
17. The combined hours of operation of the two auxiliary boilers shall be limited to 3300 hours per rolling 12-month period (ARM 17.8.710).
18. The stack height for each of the auxiliary boilers shall, at a minimum, be maintained at 259.9 feet above ground level (ARM 17.8.710).
19. The sulfur content of the No. 2 fuel oil used in the auxiliary boilers shall not exceed 0.05% sulfur (ARM 17.8.710).
20. The hours of operation of the emergency backup diesel generator shall not exceed 200 hours per rolling 12-month period (ARM 17.8.710).

21. Roundup Power shall use any one of the following methods or combination of the following methods to control particulate matter emissions from the coal handling transfer points: dust suppression systems and/or enclosures (ARM 17.8.308 and ARM 17.8.715).
22. Roundup Power shall install, operate, and maintain a bin exhaust filter (VE-15) on the surge hopper of the Crusher House to control the particulate emissions from transfer points #15, #16, and #17 (ARM 17.8.715).
23. Roundup Power shall install, operate, and maintain a baghouse (EP-27) on the Unit #1 Tripper Room Silo Vent to control the emissions from transfer points #20, #21, and #23 (ARM 17.8.715).
24. Roundup Power shall install, operate, and maintain a baghouse (EP-26) on the Unit #2 Tripper Room Silo Vent to control the emissions from transfer points #22, #24, and #25 (ARM 17.8.715).
25. Roundup Power shall install and use a wind fence, use dust suppression sprays, and use pile compaction to control particulate emissions from the inactive storage pile (ARM 17.8.715).
26. Roundup Power shall install and use a wind fence and use dust suppression sprays to control particulate emissions from the active storage pile (ARM 17.8.715).
27. Roundup Power shall handle/transfer all lime using a pneumatic system (ARM 17.8.715).
28. Roundup Power shall install, operate, and maintain a bin exhaust filter to control the particulate emissions from the emission source points for the lime storage silo bin (VE-42) and the lime feed bin (VE-43) (ARM 17.8.715).
29. Roundup Power shall use a vacuum-pressure system to transfer all fly ash (ARM 17.8.715).
30. Roundup Power shall install, operate, and maintain a bin exhaust filter to control the particulate emissions from the emission source points for the fly ash handling system (EP-50, EP-51, EP-52, EP-53, and EP-54) (ARM 17.8.715).
31. All baghouses/bin exhaust filters used to control emissions from coal handling, lime handling, and fly ash handling shall be designed, maintained, and operated such that particulate emissions do not exceed 0.01 gr/dscf (ARM 17.8.715).
32. Roundup Power shall utilize air-cooled condensers (ACC) within the process (ARM 17.8.710).
33. Roundup Power shall comply with all applicable standards and limitations, and the reporting, recordkeeping, and notification requirements contained in 40 CFR 60, Subpart Da (ARM 17.8.340 and 40 CFR 60).
34. Roundup Power shall comply with all applicable standards and limitations, and the reporting, recordkeeping, and notification requirements contained in 40 CFR 60, Subpart Db (ARM 17.8.340 and 40 CFR 60).
35. Roundup Power shall comply with all applicable standards and limitations, and the reporting, recordkeeping, and notification requirements contained in 40 CFR 60, Subpart Y (ARM 17.8.340 and 40 CFR 60).

36. Roundup Power shall comply with all applicable standards and limitations, and the reporting, recordkeeping, and notification requirements of the Acid Rain Program contained in 40 CFR 72-78 (40 CFR 72 through 40 CFR 78).

B. Testing Requirements

1. Roundup Power shall test each of the two 390-MW PC boilers for NO_x and CO, concurrently, within 180 days of initial start-up of the respective boiler, or according to another testing/monitoring schedule as may be approved by the Department of Environmental Quality (Department), to demonstrate compliance with the NO_x and CO emission limits contained in Section II.A.6 and II.A.7. The testing of each boiler shall continue on an annual basis, or according to another testing/monitoring schedule as may be approved by the Department (ARM 17.8.105 and 17.8.710).
2. Roundup Power shall test each of the two 390-MW PC boilers for SO₂ within 180 days of initial start-up of the respective boiler, or according to another testing/monitoring schedule as may be approved by the Department, to demonstrate compliance with the SO₂ emission limits contained in Section II.A.8. The testing of each boiler shall continue on an annual basis, or according to another testing/monitoring schedule as may be approved by the Department (ARM 17.8.105 and 17.8.710).
3. Roundup Power shall test each of the two 390-MW PC boilers for PM₁₀ within 180 days of initial start-up of the respective boiler, or according to another testing/monitoring schedule as may be approved by the Department, to demonstrate compliance with the PM₁₀ emission limits contained in Section II.A.9. The testing of each boiler shall continue on an annual basis, or according to another testing/monitoring schedule as may be approved by the Department (ARM 17.8.105 and 17.8.710).
4. Roundup Power shall test each of the two auxiliary boilers for NO_x and CO, concurrently, within 180 days of initial start-up of the respective boiler, or according to another testing/monitoring schedule as may be approved by the Department, to demonstrate compliance with the NO_x and CO emission limits contained in Section II.A.14 and II.A.15. The testing of each boiler shall continue on an every 5-year basis, or according to another testing/monitoring schedule as may be approved by the Department (ARM 17.8.105 and 17.8.710).
5. Roundup Power shall test each of the two auxiliary boilers for SO₂ within 180 days of initial start-up of the respective boiler, or according to another testing/monitoring schedule as may be approved by the Department, to demonstrate compliance with the SO₂ emission limit contained in Section II.A.13 (ARM 17.8.105 and 17.8.710).
6. All compliance source tests shall conform to the requirements of the Montana Source Test Protocol and Procedures Manual (ARM 17.8.106).
7. The Department may require further testing (ARM 17.8.105).

C. Operational Reporting Requirements

1. Roundup Power shall supply the Department with annual production information for all emission points, as required by the Department in the annual emission inventory request. The request will include, but is not limited to, all sources of emissions identified in the emission inventory contained in the permit analysis.

Production information shall be gathered on a calendar-year basis and submitted to the Department by the date required in the emission inventory request. Information shall be in the units required by the Department. This information may be used to calculate operating fees, based on actual emissions from the facility, and/or to verify compliance with permit limitations (ARM 17.8.505).

2. Roundup Power shall notify the Department of any construction or improvement project conducted pursuant to ARM 17.8.705(l)(r), that would include a change in control equipment, stack height, stack diameter, stack flow, stack gas temperature, source location or fuel specifications, or would result in an increase in source capacity above its permitted operation or the addition of a new emission unit.

The notice must be submitted to the Department, in writing, 10 days prior to start up or use of the proposed de minimis change, or as soon as reasonably practicable in the event of an unanticipated circumstance causing the de minimis change, and must include the information requested in ARM 17.8.705(l)(r)(iv) (ARM 17.8.705).

3. All records compiled in accordance with this permit must be maintained by Roundup Power as a permanent business record for at least 5 years following the date of the measurement, must be available at the plant site for inspection by the Department, and must be submitted to the Department upon request (ARM 17.8.710).
4. Roundup Power shall document, by month, the primary fuel feed rate for each of the two 390- MW PC boilers. By the 25th day of each month, Roundup Power shall total the primary fuel feed rate for each of the boilers during the previous 12 months to verify compliance with the limitation in Section II.A.4. A written report of the compliance verification shall be submitted along with annual emission inventory (ARM 17.8.710).
5. Roundup Power shall document, by month, the annual heat input to each of the 390-MW PC boilers. By the 25th day of each month, Roundup Power shall total the annual heat input to each of the boilers during the previous 12 months to verify compliance with the limitation in Section II.A.5. A written report of the compliance verification shall be submitted along with annual emission inventory (ARM 17.8.710).
6. Roundup Power shall document, by month, the combined diesel consumption of the two auxiliary boilers. By the 25th day of each month, Roundup Power shall total the combined diesel consumption of the two auxiliary boilers during the previous 12 months to verify compliance with the limitation in Section II.A.16. A written report of the compliance verification shall be submitted along with annual emission inventory (ARM 17.8.710).
7. Roundup Power shall document, by month, the combined hours of operation of the two auxiliary boilers. By the 25th day of each month, Roundup Power shall total the combined hours of operation of the two auxiliary boilers during the previous 12 months to verify compliance with the limitation in Section II.A.17. A written report of the compliance verification shall be submitted along with annual emission inventory (ARM 17.8.710).
8. Roundup Power shall document, by month, the hours of operation of the emergency backup diesel generator. By the 25th day of each month, Roundup Power shall total the hours of operation of the emergency backup diesel generator during the previous 12 months to verify compliance with the limitation in Section II.A.20. A written report of the compliance verification shall be submitted along with annual emission inventory (ARM 17.8.710).

D. Continuous Monitoring System Requirements

1. Roundup Power shall install, operate, calibrate, and maintain continuous monitoring systems for the following:
 - a. A continuous emission monitoring system (CEMS) for the measurement of SO₂ shall be operated on each main boiler stack (ARM 17.8.340; 40 CFR 60, Subpart Da; 40 CFR 60, Subpart Db; and 40 CFR 72-78).
 - b. A flow monitoring system to complement the SO₂ monitoring system shall be operated on each main boiler stack (ARM 17.8.340 and 40 CFR 72-78).
 - c. A CEMS for the measurement of NO_x shall be operated on each main boiler stack (ARM 17.8.340; 40 CFR 60, Subpart Da; 40 CFR 60, Subpart Db; and 40 CFR 72-78).
 - d. A CEMS for the measurement of opacity shall be operated on each main boiler stack (ARM 17.8.340; 40 CFR 60, Subpart Da; 40 CFR 60, Subpart Db; and 40 CFR 72-78).
 - e. A CEMS for the measurement of oxygen (O₂) or carbon dioxide (CO₂) content shall be operated on each main boiler stack (ARM 17.8.340 and 40 CFR 60, Subpart Da).
 - f. A CEMS for the measurement of CO₂ content shall be operated on each main boiler stack (ARM 17.8.340 and 40 CFR 72-78).
2. All continuous monitors required by this permit and by 40 CFR Part 60 shall be operated, excess emissions reported, and performance tests conducted in accordance with the requirements of 40 CFR Part 60, Subpart Da; 40 CFR Part 60, Subpart Db; 40 CFR Part 60, Appendix B (Performance Specifications #1, #2, and #3); and 40 CFR 72-78 (ARM 17.8.340 and 40 CFR 60).

E. Notification

1. Roundup Power shall provide the Department (both the Billings regional and Helena offices) with written notification of the following dates within the specified time periods (ARM 17.8.710):
 - a. Commencement of construction of the power generation facility within 30 days after commencement of construction;
 - b. Anticipated start-up date of the facility postmarked not more than 60 days nor less than 30 days prior to start-up;
 - c. Actual start-up date of the first 390-MW boiler within 15 days after the actual start-up of the boiler;
 - d. Actual start-up date of the second 390-MW boiler within 15 days after the actual start-up of the boiler,
 - e. All compliance source tests as required by the Montana Source Test Protocol and Procedures Manual (ARM 17.8.106), and
 - f. Any malfunction that occurs that can be expected to create emissions in excess of any applicable emission limitations or can be expected to last for a period greater than 4 hours shall be reported to the Department promptly by telephone (ARM 17.8.110).

2. Roundup Power shall provide the Department (both the Billings regional and Helena offices) with written notification of the following items within 30 days after actual startup of the power generation facility, or another time period as may be approved by the Department (ARM 17.8.710):
 - a. Make, model, type, size, serial number, year of manufacture, and year of installation of all proposed process equipment identified in Section 4.0 of Montana Air Quality Permit Application #3182-00.
 - b. Make, model, type, size, serial number, year of manufacture, and year of installation of all proposed control equipment identified in Section 5.0 of Montana Air Quality Permit Application #3182-00.

SECTION III: General Conditions

- A. Inspection – Roundup Power shall allow the Department’s representatives access to the source at all reasonable times for the purpose of making inspections or surveys, collecting samples, obtaining data, auditing any monitoring equipment (CEMS, CERMS) or observing any monitoring or testing, and otherwise conducting all necessary functions related to this permit.
- B. Waiver – The permit and the terms, conditions, and matters stated herein shall be deemed accepted if Roundup Power fails to appeal as indicated below.
- C. Compliance with Statutes and Regulations – Nothing in this permit shall be construed as relieving Roundup Power of the responsibility for complying with any applicable federal or Montana statute, rule or standard, except as specifically provided in ARM 17.8.701, *et seq.* (ARM 17.8.717).
- D. Enforcement – Violations of limitations, conditions and requirements contained herein may constitute grounds for permit revocation, penalties or other enforcement action as specified in Section 75-2-401, *et seq.*, MCA.
- E. Appeals – Any person or persons jointly or severally adversely affected by the Department’s decision may request, within 15 days after the Department renders its decision, upon affidavit setting forth the grounds therefore, a hearing before the Board of Environmental Review (Board). A hearing shall be held under the provisions of the Montana Administrative Procedures Act. The Department’s decision on the application is not final unless 15 days have elapsed and there is no request for a hearing under this section. The filing of a request for a hearing postpones the effective date of the Department’s decision until conclusion of the hearing and issuance of a final decision by the Board.
- F. Permit Inspection – As required by ARM 17.8.716, Inspection of Permit, a copy the air quality permit shall be made available for inspection by the Department at the location of the source.
- G. Permit Fee – Pursuant to Section 75-2-220, MCA, as amended by the 1991 Legislature, failure to pay the annual operation fee by Roundup Power may be grounds for revocation of this permit, as required by that section and rules adopted thereunder by the Board.
- H. Construction Commencement – Construction must begin within 3 years of permit issuance and proceed with due diligence until the project is complete or the permit shall be revoked (ARM 17.8.731).

Attachment 2

INSTRUCTIONS FOR COMPLETING EXCESS EMISSION REPORTS

PART 1 Complete as shown. Report total time during the reporting period in hours. The determination of plant operating time (in hours) includes time during unit start up, shut down, malfunctions, or whenever pollutants of any magnitude are generated, regardless of unit condition or operating load.

Excess emissions include all time periods when emissions, as measured by the CEMS, exceed any applicable emission standard for any applicable time period.

Percent of time in compliance is to be determined as:

$$(1 - (\text{total hours of excess emissions during reporting period} / \text{total hours of CEMS availability during reporting period})) \times 100$$

PART 2 Complete as shown. Report total time the point source operated during the reporting period in hours. The determination of point source operating time includes time during unit start up, shut down, malfunctions, or whenever pollutants (of any magnitude) are generated, regardless of unit condition or operating load.

Percent of time CEMS was available during point source operation is to be determined as:

$$(1 - (\text{CEMS downtime in hours during the reporting period}^a / \text{total hours of point source operation during reporting period})) \times 100$$

a - All time required for calibration and to perform preventative maintenance must be included in the opacity CEMS downtime.

PART 3 Complete a separate sheet for each pollutant control device. Be specific when identifying control equipment operating parameters. For example: number of TR units, energized for ESPs; pressure drop and effluent temperature for baghouses; and bypass flows and pH levels for scrubbers. For the initial EER, include a diagram or schematic for each piece of control equipment.

PART 4 Use Table I as a guideline to report all excess emissions. Complete a separate sheet for each monitor. Sequential numbering of each excess emission is recommended. For each excess emission, indicate: 1) time and duration, 2) nature and cause, and 3) action taken to correct the condition of excess emissions. Do not use computer reason codes for corrective actions or nature and cause; rather, be specific in the explanation. If no excess emissions occur during the quarter, it must be so stated.

PART 5 Use Table II as a guideline to report all CEM system upsets or malfunctions. Complete a separate sheet for each monitor. List the time, duration, nature and extent of problems, as well as the action taken to return the CEM system to proper operation. Do not use reason codes for nature, extent or corrective actions. Include normal calibrations and maintenance as prescribed by the monitor manufacturer. Do not include zero and span checks.

PART 6 Complete a separate sheet for each pollutant control device. Use Table III as a guideline to report operating status of control equipment during the excess emission. Follow the number sequence as recommended for excess emissions reporting. Report operating parameters consistent with Part 3, Subpart e.

PART 7 Complete a separate sheet for each monitor. Use Table IV as a guideline to summarize excess emissions and monitor availability.

PART 8 Have the person in charge of the overall system and reporting certify the validity of the report by signing in Part 8.

EXCESS EMISSIONS REPORT

PART 1

- a. Emission Reporting Period _____
- b. Report Date _____
- c. Person Completing Report _____
- d. Plant Name _____
- e. Plant Location _____
- f. Person Responsible for Review
and Integrity of Report _____
- g. Mailing Address for 1.f.

- h. Phone Number of 1.f. _____
- i. Total Time in Reporting Period _____
- j. Total Time Plant Operated During Quarter _____
- k. Permitted Allowable Emission Rates: Opacity
SO₂ _____ NO_x _____ TRS _____
- l. Percent of Time Out of Compliance: Opacity
SO₂ _____ NO_x _____ TRS _____
- m. Amount of Product Produced
During Reporting Period _____
- n. Amount of Fuel Used During Reporting Period _____

PART 2 - Monitor Information: Complete for each monitor.

a. Monitor Type (circle one)

Opacity SO₂ NO_x O₂ CO₂ TRS Flow

b. Manufacturer _____

c. Model No. _____

d. Serial No. _____

e. Automatic Calibration Value: Zero _____ Span _____

f. Date of Last Monitor Performance Test _____

g. Percent of Time Monitor Available:

1) During reporting period _____

2) During plant operation _____

h. Monitor Repairs or Replaced Components Which Affected or Altered Calibration Values _____

i. Conversion Factor (f-Factor, etc.)

j. Location of monitor (e.g. control equipment outlet)

PART 3 - Parameter Monitor of Process and Control Equipment. (Complete one sheet for each pollutant.)

a. Pollutant (circle one):

Opacity SO₂ NO_x TRS

b. Type of Control Equipment _____

c. Control Equipment Operating Parameters (i.e., delta P, scrubber water flow rate, primary and secondary amps, spark rate)

d. Date of Control Equipment Performance Test _____

e. Control Equipment Operating Parameter During Performance Test

PART 4 - Excess Emission (by Pollutant)

Use Table I: Complete table as per instructions. Complete one sheet for each monitor.

PART 5 - Continuous Monitoring System Operation Failures

Use Table II: Complete table as per instructions. Complete one sheet for each monitor.

PART 6 - Control Equipment Operation During Excess Emissions

Use Table III: Complete as per instructions. Complete one sheet for each pollutant control device.

PART 7 - Excess Emissions and CEMS performance Summary Report

Use Table IV: Complete one sheet for each monitor.

PART 8 - Certification for Report Integrity, by person in 1.f.

THIS IS TO CERTIFY THAT, TO THE BEST OF MY KNOWLEDGE, THE INFORMATION PROVIDED IN THE ABOVE REPORT IS COMPLETE AND ACCURATE.

SIGNATURE _____

NAME _____

TITLE _____

DATE _____

TABLE I
EXCESS EMISSIONS

<u>Date</u>	<u>Time</u>		<u>Duration</u>	<u>Magnitude</u>	<u>Explanation/Corrective Action</u>
	<u>From</u>	<u>To</u>			

TABLE II

CONTINUOUS MONITORING SYSTEM OPERATION FAILURES

<u>Date</u>	<u>Time</u>		<u>Duration</u>	<u>Problem/Corrective Action</u>
	<u>From</u>	<u>To</u>		

TABLE III
CONTROL EQUIPMENT OPERATION DURING EXCESS EMISSIONS

<u>Date</u>	<u>Time</u>		<u>Duration</u>	<u>Operating Parameters</u>	<u>Corrective Action</u>
	<u>From</u>	<u>To</u>			

TABLE IV

Excess Emission and CEMS Performance Summary Report

Pollutant (circle one): SO₂ NO_x TRS H₂S CO Opacity

Monitor ID

Emission data summary ¹	CEMS performance summary ¹
<p>1. Duration of excess emissions in reporting period due to:</p> <ul style="list-style-type: none"> a. Startup/shutdown b. Control equipment problems c. Process problems d. Other known causes e. Unknown causes <p>2. Total duration of excess emissions</p> <p>3. $\left[\frac{\text{Total duration of excess emissions}}{\text{Total time CEM operated}} \times 100 = \right]$</p>	<p>1. CEMS² downtime in reporting due to:</p> <ul style="list-style-type: none"> a. Monitor equipment malfunctions b. Non-monitor equipment malfunctions c. Quality assurance calibration d. Other known causes e. Unknown causes <p>2. Total CEMS downtime</p> <p>3. $\left[\frac{\text{Total CEMS downtime}}{\text{Total time source emitted}} \times 100 = \right]$</p>

¹ For opacity, record all times in minutes. For gases, record all times in hours. Fractions are acceptable (e.g., 4.06 hours)

² CEMS downtime shall be regarded as any time CEMS is not measuring emissions.

Permit Analysis
Roundup Power Project
Permit #3182-00

I. Introduction/Process Description

A. Permitted Equipment

The Roundup Power Project (Roundup Power) facility will be located approximately 35 miles north of Billings and 12 miles south-southeast of the town of Roundup. The facility's primary equipment will consist of the following:

- Two main boilers with dry Flue Gas Desulfurization (FGD) systems, Selective Catalytic Reduction (SCR) systems, and pulse jet baghouses. The boilers will use coal as their primary fuel and No.2 fuel oil for startup.
- Two steam turbine-generators rated at 390-megawatt (MW) gross electrical output each.
- Two air-cooled condensers.
- Two auxiliary boilers fueled with No.2 fuel oil.
- One emergency generator fueled with No.2 fuel oil.
- Storage and handling equipment for coal, lime, ash, and No.2 fuel oil.
- 4000-foot long overland conveyor.

B. Source Description

Coal for the main boilers will be supplied by the BMP Investments Incorporated coal mine that is located on the adjacent property immediately to the east of the power plant location. The coal will be transferred to the power plant via a 4000-foot long overland conveyor. The coal that is transferred to the power plant facility will be stored in either the active coal storage pile or in the inactive coal storage pile. The inactive coal storage pile will consist of approximately 92,500 tons of coal (11 days worth of coal storage for the power plant).

From the active coal storage pile (Transfer House 1), coal will be transferred to the 25,000-ton capacity reclaim hoppers (3 days worth of coal storage), and then on to the crusher house. From the crusher house, coal is transferred via conveyors to the main boilers for combustion.

II. Applicable Rules and Regulations

The following are partial explanations of some applicable rules and regulations that apply to the facility. The complete rules are stated in the Administrative Rules of Montana (ARM) and are available, upon request, from the Department of Environmental Quality (Department). Upon request, the Department will provide references for location of complete copies of all applicable rules and regulations or copies where appropriate.

A. ARM 17.8, Subchapter 1 – General Provisions, including but not limited to:

1. ARM 17.8.101 Definitions. This rule includes a list of applicable definitions used in this chapter, unless indicated otherwise in a specific subchapter.

2. ARM 17.8.105 Testing Requirements. Any person or persons responsible for the emission of any air contaminant into the outdoor atmosphere shall, upon written request of the Department, provide the facilities and necessary equipment (including instruments and sensing devices) and shall conduct test, emission or ambient, for such periods of time as may be necessary using methods approved by the Department.
3. ARM 17.8.106 Source Testing Protocol. The requirements of this rule apply to any emission source testing conducted by the Department, any source or other entity as required by any rule in this chapter, or any permit or order issued pursuant to this chapter, or the provisions of the Clean Air Act of Montana, 75-2-101, et seq., Montana Code Annotated (MCA).

Roundup Power shall comply with the requirements contained in the Montana Source Test Protocol and Procedures Manual, including, but not limited to, using the proper test methods and supplying the required reports. A copy of the Montana Source Test Protocol and Procedures Manual is available from the Department upon request.

4. ARM 17.8.110 Malfunctions. (2) The Department must be notified promptly by telephone whenever a malfunction occurs that can be expected to create emissions in excess of any applicable emission limitation or to continue for a period greater than 4 hours.
5. ARM 17.8.111 Circumvention. (1) No person shall cause or permit the installation or use of any device or any means that, without resulting in reduction of the total amount of air contaminant emitted, conceals or dilutes an emission of air contaminant that would otherwise violate an air pollution control regulation. (2) No equipment that may produce emissions shall be operated or maintained in such a manner as to create a public nuisance.

B. ARM 17.8, Subchapter 2 – Ambient Air Quality, including, but not limited to the following:

1. ARM 17.8.204 Ambient Air Monitoring
2. ARM 17.8.210 Ambient Air Quality Standards for Sulfur Dioxide
3. ARM 17.8.211 Ambient Air Quality Standards for Nitrogen Dioxide
4. ARM 17.8.212 Ambient Air Quality Standards for Carbon Monoxide
5. ARM 17.8.213 Ambient Air Quality Standard for Ozone
6. ARM 17.8.214 Ambient Air Quality Standard for Hydrogen Sulfide
7. ARM 17.8.220 Ambient Air Quality Standard for Settled Particulate Matter
8. ARM 17.8.221 Ambient Air Quality Standard for Visibility
9. ARM 17.8.222 Ambient Air Quality Standard for Lead
10. ARM 17.8.223 Ambient Air Quality Standard for PM₁₀

Roundup Power must maintain compliance with the applicable ambient air quality standards.

C. ARM 17.8, Subchapter 3 – Emission Standards, including, but not limited to:

1. ARM 17.8.304 Visible Air Contaminants. This rule requires that no person may cause or authorize emissions to be discharged into the outdoor atmosphere from any source installed after November 23, 1968, that exhibit an opacity of 20% or greater averaged over 6 consecutive minutes.
2. ARM 17.8.308 Particulate Matter, Airborne. (1) This rule requires an opacity limitation of 20% for all fugitive emission sources and that reasonable precautions be taken to control emissions of airborne particulate matter. (2) Under this rule, Roundup Power shall not cause or authorize the use of any street, road, or parking lot without taking reasonable precautions to control emissions of airborne particulate matter.

3. ARM 17.8.309 Particulate Matter, Fuel Burning Equipment. This rule requires that no person shall cause, allow, or permit to be discharged into the atmosphere particulate matter caused by the combustion of fuel in excess of the amount determined by this rule.
4. ARM 17.8.310 Particulate Matter, Industrial Process. This rule requires that no person shall cause, allow, or permit to be discharged into the atmosphere particulate matter in excess of the amount set forth in this rule.
5. ARM 17.8.322 Sulfur Oxide Emissions--Sulfur in Fuel. (4) Commencing July 1, 1972, no person shall burn liquid or solid fuels containing sulfur in excess of 1 pound of sulfur per million Btu fired. Roundup Power will comply with this limitation by combusting low sulfur coal and using dry flue gas desulfurization.
6. ARM 17.8.324 Hydrocarbon Emissions--Petroleum Products. (3) No person shall load or permit the loading of gasoline into any stationary tank with a capacity of 250 gallons or more from any tank truck or trailer, except through a permanent submerged fill pipe, unless such tank is equipped with a vapor loss control device as described in (1) of this rule.
7. ARM 17.8.340 Standard of Performance for New Stationary Sources and Emission Guidelines for Existing Sources. This rule incorporates, by reference, 40 CFR 60, Standards of Performance for New Stationary Sources (NSPS). Roundup Power is considered an NSPS affected facility under 40 CFR 60 and is subject to the requirements of the following subparts.

40 CFR Part 60, Subpart A – General Provisions. This subpart applies to all affected equipment or facilities subject to an NSPS subpart as listed below.

40 CFR 60, Subpart Da, Standards of Performance Electric Utility Steam Generating Units for Which Construction is Commenced after September 18, 1978. Roundup Power is an affected facility under this subpart because 1) the electric utility steam generating units are capable of combusting more than 73-MW heat input of fossil fuel and 2) the construction of the facility would occur after September 18, 1978.

40 CFR 60, Subpart Db, Standards of Performance for Industrial-Commercial-Institutional Steam Generating Units. Roundup Power is an affected facility under this subpart because 1) the steam generating units will commence construction after June 19, 1984 and 2) the facility will have a heat input capacity from fuels combusted in the steam generating unit of greater than 29 MW.

40 CFR 60, Subpart Y, Standards of Performance for Coal Preparation Plants. Roundup Power is an affected facility under this subpart because 1) the facility meets the definition of a coal preparation facility as defined in §60.251, 2) the facility has coal processing and conveying equipment (including breakers and crushers), and 3) the facility would process more than 200 tons of coal per day.

8. ARM 17.8.341 Emission Standards for Hazardous Air Pollutants. This source shall comply with the standards and provisions of 40 CFR 61.
9. ARM 17.8.342 Emission Standards for Hazardous Air Pollutants for Source Categories. This source, as defined and applied in 40 CFR 63, shall comply with the requirements of 40 CFR 63.

- D. ARM 17.8, Subchapter 4 – Stack Height and Dispersion Techniques, including, but not limited to:
1. ARM 17.8.401 Definitions. This rule includes a list of definitions used in this chapter, unless indicated otherwise in a specific subchapter.
 2. ARM 17.8.402 Requirements. Roundup Power must demonstrate compliance with the ambient air quality standards with a stack height that does not exceed Good Engineering Practices (GEP). The proposed height of the new or altered stack for Roundup Power is below the allowable GEP stack height.
- E. ARM 17.8, Subchapter 5 – Air Quality Permit Application, Operation and Open Burning Fees, including, but not limited to:
1. ARM 17.8.504 Air Quality Permit Application Fees. This rule requires that an applicant submit an air quality permit application fee concurrent with the submittal of an air quality permit application. A permit application is incomplete until the proper application fee is paid to the Department. Roundup Power submitted the appropriate permit application fee for the current permit action.
 2. ARM 17.8.505 When Permit Required--Exclusions. An annual air quality operation fee must, as a condition of continued operation, be submitted to the Department by each source of air contaminants holding an air quality permit (excluding an open burning permit) issued by the Department. The air quality operation fee is based on the actual or estimated actual amount of air pollutants emitted during the previous calendar year.

An air quality operation fee is separate and distinct from an air quality permit application fee. The annual assessment and collection of the air quality operation fee, described above, shall take place on a calendar-year basis. The Department may insert into any final permit issued after the effective date of these rules, such conditions as may be necessary to require the payment of an air quality operation fee on a calendar-year basis, including provisions that prorate the required fee amount.
- F. ARM 17.8, Subchapter 7 – Permit, Construction and Operation of Air Contaminant Sources, including, but not limited to:
1. ARM 17.8.701 Definitions. This rule is a list of applicable definitions used in this chapter, unless indicated otherwise in a specific subchapter.
 2. ARM 17.8.704 General Procedures for Air Quality Preconstruction Permitting. This air quality preconstruction permit contains requirements and conditions applicable to both construction and subsequent use of the permitted equipment.
 3. ARM 17.8.705 When Permit Required--Exclusions. This rule requires a facility to obtain an air quality permit or permit alteration if they construct, alter or use any air contaminant sources that have the potential to emit greater than 25 tons per year of any pollutant.
 4. ARM 17.8.706 New or Altered Sources and Stacks--Permit Application Requirements. This rule requires that a permit application be submitted prior to installation, alteration or use of a source. Roundup Power submitted the required permit application for the current permit action.

5. ARM 17.8.707 Waivers. ARM 17.8.706 requires that a permit application be submitted 180 days before construction begins. This rule allows the Department to waive this time limit. The Department hereby waives this time limit.
 6. ARM 17.8.710 Conditions for Issuance of Permit. This rule requires that Roundup Power demonstrate compliance with applicable rules and standards before a permit can be issued. Also, a permit may be issued with such conditions as are necessary to ensure compliance with all applicable rules and standards. Roundup Power demonstrated compliance with all applicable rules and standards as required for permit issuance.
 7. ARM 17.8.715 Emission Control Requirements. This rule requires a source to install the maximum air pollution control capability that is technically practicable and economically feasible, except that Best Available Control Technology (BACT) shall be utilized. The required BACT analysis is included in Section III of this permit analysis.
 8. ARM 17.8.716 Inspection of Permit. This rule requires that air quality permits shall be made available for inspection by the Department at the location of the source.
 9. ARM 17.8.717 Compliance with Other Statutes and Rules. This rule states that nothing in the permit shall be construed as relieving Roundup Power of the responsibility for complying with any applicable federal or Montana statute, rule, or standard, except as specifically provided in ARM 17.8.701, *et seq.*
 10. ARM 17.8.720 Public Review of Permit Applications. The rule requires that the applicant notify the public by means of legal publication in a newspaper of general circulation in the area affected by the application for a permit. Roundup Power submitted an affidavit of publication of public notice for the January 18, 2002, issue of the *Billings Gazette*, a newspaper of general circulation in the city of Billings in Yellowstone County, as proof of compliance with the public notice requirements. Roundup Power submitted a second affidavit of publication of public notice for the January 23, 2002, issue of the *Roundup Record-Tribune* and *The Winnett Times*, newspapers of general circulation in the area of the project, as proof of compliance with the public notice requirements.
 11. ARM 17.8.731 Duration of Permit. An air quality permit shall be valid until revoked or modified, as provided in this subchapter, except that a permit issued prior to construction of a new or altered source may contain a condition providing that the permit will expire unless construction is commenced within the time specified in the permit, which in no event may be less than 1 year after the permit is issued.
 12. ARM 17.8.733 Modification of Permit. An air quality permit may be modified for changes in any applicable rules and standards adopted by the Board of Environmental Review (Board) or changed conditions of operation at a source or stack that do not result in an increase of emissions as a result of those changed conditions. A source may not increase its emissions beyond those found in its permit unless the source applies for and receives another permit.
 13. ARM 17.8.734 Transfer of Permit. This rule states that an air quality permit may be transferred from one person to another if written notice of Intent to Transfer, including the names of the transferor and the transferee, is sent to the Department.
- G. ARM 17.8, Subchapter 8 – Prevention of Significant Deterioration of Air Quality, including, but not limited to:

1. ARM 17.8.801 Definitions. This rule is a list of applicable definitions used in this subchapter.
2. ARM 17.8.818 Review of Major Stationary Sources and Major Modifications--Source Applicability and Exemptions. The requirements contained in ARM 17.8.819 through ARM 17.8.827 shall apply to any major stationary source and any major modification, with respect to each pollutant subject to regulation under the Federal Clean Air Act (FCAA) that it would emit, except as this subchapter would otherwise allow.

This facility is a listed source because it is a fossil-fuel fired steam-electric plant having more than 250 MMBtu/hr heat input. Furthermore, the facility's emissions are greater than 100 tons per year; therefore, the facility is a major source under the New Source Review (NSR)-Prevention of Significant Deterioration (PSD) program.

H. ARM 17.8, Subchapter 12 – Operating Permit Program Applicability, including, but not limited to:

1. ARM 17.8.1201 Definitions. (23) Major Source under Section 7412 of the FCAA is defined as any source having:
 - a. Potential to Emit (PTE) > 100 tons/year of any pollutant;
 - b. PTE > 10 tons/year of any one Hazardous Air Pollutant (HAP), PTE > 25 tons/year of a combination of all HAPs, or lesser quantity as the Department may establish by rule; or
 - c. Sources with the PTE > 70 tons/year of PM₁₀ in a serious PM₁₀ nonattainment area.
2. ARM 17.8.1204 Air Quality Operating Permit Program. (1) Title V of the FCAA amendments of 1990 requires that all sources, as defined in ARM 17.8.1204(1), obtain a Title V Operating Permit. In reviewing and issuing Air Quality Permit #3182-00 for Roundup Power, the following conclusions were made.
 - a. The facility's PTE is greater than 100 tons/year for PM₁₀, SO₂, NO_x, and VOCs.
 - b. The facility's PTE is greater than 10 tons/year for an individual HAP and greater than 25 tons/year for the combination of all HAPs.
 - c. This source is not located in a serious PM₁₀ nonattainment area.
 - d. This facility is subject to several current New Source Performance Standards (NSPS).
 - e. This facility is currently subject to case-by-case MACT. As appropriate, the electric utility MACT standards will apply to the facility once they are promulgated.
 - f. This source is a Title IV affected source.
 - g. This source is not an EPA designated Title V source.

Based on these facts, the Department determined that Roundup Power is a major source of emissions as defined under the Title V Operating Permit Program.

III. BACT Determination

A BACT determination is required for each new or altered source. Roundup Power shall install on the new or altered source the maximum air pollution control capability which is technically practicable and economically feasible, except that BACT shall be utilized. A BACT analysis was submitted by Roundup Power in Permit Application #3182-00, addressing some available methods of controlling emissions from the power plant's main boilers, auxiliary boilers, backup generator, and fugitive emissions. A BACT analysis has been performed for the following boiler emissions: CO, NO_x, SO₂, PM₁₀, and VOCs. A BACT analysis was also performed for PM₁₀ emissions from the fuel handling and storage, lime handling and storage, and ash handling and storage.

The Department reviewed these methods, as well as previous BACT determinations. The following control options have been reviewed by the Department in order to make the following BACT determination.

A. Main Boilers (MB-1 and MB-2)

1. NO_x Emissions

Two types of control methods exist for NO_x--combustion controls and post-combustion controls. Combustion controls reduce the amount of NO_x that is generated in the boiler, while post-combustion controls remove NO_x from the boiler exhaust gas.

- a. Low Excess Air (LEA) - LEA technology is a combustion control. Combustion processes typically require excess air in order to ensure that fuel molecules find and react with oxygen. With LEA, the amount of excess air supplied to the firing chamber is reduced, thereby lowering the combustion temperature. The lower combustion temperature reduces the amount of thermal NO_x formed during the combustion process. Incorporating LEA into boiler design is a technologically feasible option and is common with current boiler design.
- b. Low NO_x Burners (LNB) - LNB technology is a combustion control. LNBs limit NO_x formation by controlling both the stoichiometric and temperature profiles of the combustion flame in each burner flame envelope. This control is achieved with design features that regulate the aerodynamic distribution and mixing of the fuel and air, yielding reduced oxygen residence time at peak combustion temperatures. The combination of these techniques produces lower NO_x emissions during the combustion process.
- c. Overfire Air (OFA) - OFA technology is a combustion control that involves the injection of air into the firing chamber in two staged zones. The staging of the combustion air reduces NO_x formation by two mechanisms. The staged combustion results in a cooler flame, and the staged combustion results in less oxygen reacting with fuel molecules. The degree of staging is limited by operational problems since the staged combustion results in incomplete combustion conditions and a longer flame.
- d. Flue Gas Recirculation (FGR) - FGR is a combustion control that controls NO_x by recycling a portion of the flue gas back into the primary combustion zone. The recycled air lowers NO_x emissions by lowering combustion temperatures (the recycled gas is made up of combustion products, which are inert during combustion) and by lowering the oxygen content in the primary flame zone. The amount of recirculation is based on flame stability. The Department was unable to find any examples of FGR being required to control NO_x emissions from other coal-fired boilers.

- e. Selective Non-Catalytic Reduction (SNCR) - SNCR is a post combustion control that involves the direct injection of ammonia or urea at high flue gas temperatures. The ammonia (or urea) reacts with the NO_x in the flue gas to produce N_2 and water. Flue gas temperature at the point of reagent injection can greatly affect NO_x removal efficiencies and the quantity of ammonia or urea that would pass through the SNCR unreacted. If the temperature is too low, NO_x reduction reactions are less effective and ammonia emissions may increase. Conversely, if the temperature is too hot, ammonia is oxidized to NO_x , and the efficiency of NO_x reduction is reduced.

Mixing of the reactant and flue gas within the reaction zone is also an important factor to SNCR performance. In large boilers, the physical distance over which the reagent must be dispersed increases, and the surface area/volume ratio of the convective pass decreases. Both of these factors may make it difficult to achieve good mixing of the reagent and flue gas, to deliver the reagent in the proper temperature window, and to provide sufficient residence time of the reagent and flue gas in that temperature window.

In addition to temperature and mixing, several other factors influence the performance of an SNCR system, including residence time, reagent-to- NO_x ratio, and fuel sulfur content.

Both urea and ammonia-based SNCR systems have been applied to new coal-fired fluidized bed combustion (FBC) boilers. The application of SNCR to FBC boilers is feasible due to the extensive flue gas mixing which occurs as a result of the fluidizing process, and the normal operating temperature of an FBC is also at the optimum temperature for NO_x reduction by ammonia. On FBCs, SNCR systems have been designed to achieve a NO_x reduction of approximately 30-60%. However, SNCR has not been used on large pulverized coal units. Pulverized coal boilers present several design problems that make it difficult to ensure that the reagent will be injected at the optimum fuel gas temperature, and that there will be adequate mixing and residence time.

- f. Selective Catalytic Reduction (SCR) - SCR is a post combustion control that involves injecting ammonia into the boiler flue gas in the presence of a catalyst to reduce NO_x to N_2 and water. The performance of the SCR is influenced by several factors including flue gas temperature, SCR inlet NO_x level, surface area, volume and age of the catalyst, and the amount of ammonia slip that is acceptable.

The optimal temperature range depends on the type of catalyst used, but is typically between 560°F and 800°F to maximize the NO_x reduction efficiency and minimize salt formation. This temperature range typically occurs between the economizer and the air heater in a large utility boiler. Below this range, ammonium sulfate is formed resulting in catalyst deactivation. Above the optimum temperature, the catalyst will sinter and thus deactivate rapidly.

Another factor affecting SCR performance is the condition of the catalyst material. As the catalyst degrades over time or is damaged, NO_x removal decreases.

Based on the inlet NO_x concentration expected for the Roundup Power units, an 80% reduction efficiency would be anticipated using SCR.

The Department determined that a NO_x emission limit of 0.07 lb/MMBtu would constitute BACT for each of the main power boilers. The Department also determined that the use of a combination of LNBs, OFA, and SCR technology on each boiler would be necessary to meet the NO_x emission limit established through this BACT analysis.

2. PM₁₀ Emissions

The primary methods for PM₁₀ control are post-combustion methods. There are two generally recognized particulate matter control devices that are used to control particulate matter emissions from pulverized coal-fired boilers: electrostatic precipitators (ESP) and fabric filters (or baghouses). Either of these devices, if properly designed and operated, is capable of reducing particulate matter emissions below the 0.03 lb/MMBtu limit required by 40 CFR 60, Subpart Da (NSPS) as well as limiting opacity to below 20%.

For this BACT analysis, and for permitting purposes, uncontrolled particulate matter emissions from the proposed boiler were calculated based on the following assumptions: (1) 80% of the ash would be emitted as fly ash; (2) all fly ash would be emitted as filterable particulate matter; and (3) all filterable particulate matter would be classified as PM₁₀. Assuming a maximum coal ash content of 10.12% and a heating value of 9,916 Btu/lb, the maximum uncontrolled PM₁₀ emissions from the boiler would be 8.16 lb/MMBtu. This will be used as the baseline PM₁₀ emission rate for this BACT analysis.

- a. ESP - Electrostatic precipitation technology is applicable to a variety of coal combustion sources. ESPs remove particulate matter from the flue gas stream by charging fly ash particulates with a high direct current (dc) voltage and attracting these particles to charged collection plates. A layer of collected particulate forms on the collecting plates (electrodes) and is removed by rapping the electrodes. The collected particulate drops into hoppers below the precipitator and is periodically removed from the fly ash handling system.

Because of their modular design, ESPs can be applied to a wide range of system sizes and should have no adverse effect on combustion system performance. The operating parameters that influence ESP performance include fly ash mass loading, particle size distribution, fly ash electrical resistivity, and precipitator voltage and current. Other factors that determine ESP collection efficiency are collection plate area, gas flow velocity, and cleaning cycle. Data for ESPs applied to coal-fired sources show fractional collection efficiencies of approximately 95% for fine particles (less than 0.1 microns) and greater than 99% for coarse particles (greater than 10 microns). These data show a reduction in collection efficiency for particle diameters between 0.1 and 10 micrometers.

ESPs are considered a technically feasible option for Roundup Power. Based on information provided by Roundup Power, the lowest anticipated post-control PM₁₀ emission rate that could be practically achieved with ESP technology is 0.018 lb/MMBtu, which represents control efficiency of 99.78%.

- b. Fabric Filters - Fabric filtration has been widely applied to coal combustion sources and consists of a number of filtering elements (bags) along with a bag cleaning system contained in a main shell structure incorporating dust hoppers. Fabric filters use fabric bags as filters to collect particulate matter. The particulate-laden gas enters a fabric filter compartment and passes through a layer of filter bags. The collected particulate forms a cake on the bag that enhances the bag's filtering efficiency. Excessive caking would increase the pressure drop across the fabric filter at which point the filters must be cleaned.

The particulate removal efficiency of fabric filters is dependent upon a variety of particle and operational characteristics. Particle characteristics that affect the collection efficiency include particle size distribution, particle cohesion characteristics, and particle electrical resistivity. Operational parameters that may affect fabric filter collection efficiency include bag material, air-to-cloth ratio, and operating pressure loss. In addition, certain filter properties (e.g., structure of the fabric and fiber composition) can affect the system's particle collection efficiency.

Fabric filters are considered a technically feasible option to control particulate matter from the proposed boilers. Fabric filters are capable of collection efficiencies greater than 99% when appropriately sized and operated. For Roundup Power a pulse jet fabric filter system was proposed that would be designed to consistently achieve a post-control PM₁₀ emission rate of 0.015 lb/MMBtu. Based on an uncontrolled PM₁₀ emission rate of 8.16 lb/MMBtu, 0.015 lb/MMBtu represents a control efficiency of 99.82%.

The Department determined that a PM₁₀ emission limit of 0.015 lb/MMBtu constitutes BACT for each of the main power boilers. The Department also determined that the use of a fabric filter baghouse will be necessary to meet the emission limits established through this BACT analysis.

3. SO₂ Emissions

SO_x emissions from coal combustion consist primarily of SO₂ with a much lower quantity of SO₃ and gaseous sulfates. These compounds form as the organic and pyretic sulfur in the coal is oxidized during the combustion process. On average, about 95% of the sulfur present in bituminous coal will be emitted as gaseous SO_x. Boiler size, firing configuration, and boiler operations generally have little effect on the percent conversion of fuel sulfur to SO₂.

The generation of SO₂ is directly related to the sulfur content and heating value of the fuel burned. The sulfur content and heating value of coal can vary dramatically depending on the source of the coal. Roundup Power would be a mine-mouth facility and would receive coal from the BMP Investments Incorporated coal mine located adjacent to the proposed power plant.

Based on analysis of the poorest quality coal sample obtained from the BMP Investments Incorporated, the worst case heating value of coal would be approximately 9,916 Btu/lb, and the maximum sulfur content is expected to be 0.94%. Without post-combustion controls, maximum SO₂ emissions from the boiler firing this coal would be 1.9 lb/MMBtu. This emission rate was considered as the baseline emission rate for this BACT analysis.

Several techniques are used to reduce SO₂ emissions from coal combustion. Strategies for the control of SO₂ emissions can be divided into pre-combustion and post-combustion categories. A pre-combustion method is to switch to lower sulfur coals, since SO₂ emissions are proportional to the sulfur content of the coal. Post-combustion flue gas desulfurization (FGD) techniques can remove SO₂ formed during combustion.

- a. Fuel Switching - A potential control for reducing SO₂ emissions from the proposed project is reducing the amount of sulfur contained in the coal. The Roundup Power boilers are designed to burn local coal from the BMP Investments Incorporated coal mine. The coal is a bituminous western coal with a relatively high heat content and low sulfur content. Bituminous coals from mines in the eastern and midwestern U.S. generally have a higher heating value, but also have a significantly higher sulfur content. Western sub-bituminous coals may have a somewhat lower average sulfur content but also typically have lower heating values.

Roundup Power is designed as a mine-mouth project. The economics of this project are based on the availability of an abundant supply of fuel in the immediate vicinity. Therefore, burning coal from another vicinity is not consistent with the project concept. Furthermore, although burning western sub-bituminous coal may reduce the uncontrolled SO₂ emission rate somewhat, the controlled SO₂ emission rate would be essentially the same for either sub-bituminous coal or BMP Investments Incorporated coal. Overall, there is no justification, either economically or environmentally to burn a coal that may have a slightly lower sulfur content.

b. Wet Scrubbing (Lime/Limestone)

Wet FGD technology is an established SO₂ control technology. Wet FGD systems are generally categorized as lime or limestone scrubbing systems. The scrubbing process and equipment for both lime scrubbing and limestone scrubbing is similar. Some FGD systems are designed to accommodate both lime and limestone.

i. Wet Lime Scrubbing

The wet lime scrubbing process uses an alkaline slurry made by adding lime (CaO) to water. The alkaline slurry is sprayed in the absorber and reacts with SO₂ in the flue gas. Insoluble calcium sulfite (CaSO₃) and calcium sulfate (CaSO₄) salts are formed in the chemical reaction that occurs in the scrubber. The salts are removed as a solid waste by-product. The waste by-product is made up of mainly CaSO₃, which is difficult to dewater. Solid waste by-products from wet lime scrubbing are typically managed in dewatering ponds and landfills.

ii. Wet Limestone Scrubbing

Limestone scrubbers are very similar to lime scrubbers. However, the use of limestone (CaCO₃) instead of lime requires different feed preparation equipment and a higher liquid-to-gas ratio. The higher liquid-to-gas ratio typically requires a larger absorbing unit. The limestone slurry process also requires a ball mill to crush the limestone feed.

Forced oxidation of the scrubber slurry can be used with either the lime or limestone wet FGD system to produce gypsum solids instead of the calcium sulfite by-product. Forced oxidation of the scrubber slurry provides a more stable by-product and reduces the potential for scaling in the FGD. The gypsum by-product may be salable, reducing the quantity of solid waste that needs to be landfilled.

Wet lime/limestone scrubber systems can achieve SO₂ control efficiencies of greater than 95% when used for boilers burning higher sulfur bituminous coals. The actual control efficiency of a wet FGD system depends on several factors, including the uncontrolled SO₂ concentration entering the system.

Wet FGD is considered a technically feasible control option for this project. For this BACT analysis, it was assumed that the wet FGD system would consist of wet limestone scrubbing with forced oxidation. Wet lime and wet limestone scrubbing systems achieve about the same SO₂ control efficiency, however, the higher cost of lime makes wet limestone scrubbing the more attractive option of the two.

Using a maximum uncontrolled SO₂ emission rate of 1.9 lb/MMBtu, the wet limestone scrubbing system could consistently achieve 96% SO₂ removal, resulting in a controlled emission rate of 0.08 lb/MMBtu.

iii. Wet FGD with Wet Electrostatic Precipitator (WESP)

Wet FGD systems can result in increased emissions of condensable particulates and acid gases. Additional add-on technology (such as WESP) exists to address the particulate and acid gas concern associated with wet FGD. WESP operates in much the same way as a dry ESP; charging and collecting the fine particulates. However, with WESP cleaning is performed by washing the collection surfaces with water rather than cleaning by mechanical means.

Wet FGD combined with WESP (wet FGD+WESP) is considered a technically feasible option to control SO₂ and acid gases from the proposed facility. The major advantage of using this combined technology instead of wet FGD alone is the reduction of sulfuric acid mist. It is anticipated that the SO₂ emission rate would still be approximately 0.08 lb/MMBtu; however, the collateral environmental impact of the control system would be reduced.

iv. Dual-Alkali Wet Scrubber

Dual-alkali scrubbing is a desulfurization process that uses a sodium-based alkali solution to remove SO₂ from combustion exhaust gas. The process uses both sodium-based and calcium-based compounds. The sodium-based reagent absorbs SO₂ from the exhaust gas, and the calcium-based solution (lime or limestone) regenerates the spent liquor. Calcium sulfites and sulfates are precipitated and discarded as sludge, while the regenerated sodium solution is returned to the absorber loop.

The dual-alkali process requires lower liquid-to-gas ratios than scrubbing with lime or limestone. The reduced liquid-to-gas ratios generally mean smaller reaction units, however additional regeneration and sludge processing equipment is necessary.

The sodium-based scrubbing liquor, typically consisting of a mixture of sodium hydroxide, sodium carbonate, and sodium sulfite, is an efficient SO₂ control reagent. However, the high cost of the sodium-based chemicals limits the feasibility of such a unit on a large utility boiler. In addition, the process generates a less stable sludge that can create material handling and disposal problems.

The total water use demands for a wet FGD system (for two 390-MW units) would be approximately 420.5 MMgal/year, the total sorbent feed rate for a wet FGD system would be approximately 24,740 lb/hr, and the total solid waste generation rate would be approximately 206,296 ton/yr. In addition, the use of a wet FGD system by Roundup Power would result in approximately 35 gal/min of wastewater. Treatment of the wastewater may require settling, pH adjustment, desupersaturation, and chemical precipitation.

Wet FGD provides some control of H₂SO₄ emissions. The total emissions (from both units) of H₂SO₄ while using wet FGD would be approximately 1,254 tons per year. If wet FGD was used in conjunction with WESP, the total H₂SO₄ emissions would be 125 tons per year.

The use of wet FGD would potentially result in visibility impacts both locally and on a more widespread basis. Locally, the high moisture plume would be quite visible on days with cool weather or humid conditions. On a more widespread basis, the facility's modeled emissions indicate that impacts would result at Class 1 areas around the facility.

The average cost per ton of reduction was determined for wet FGD and wet FGD+WESP. For wet FGD, the average cost per ton of reduction was estimated to be \$435 and for wet FGD+WESP, the average cost per ton of reduction was estimated to be \$542.

c. Dry Flue Gas Desulfurization

An alternative to wet scrubbing that has proven to effectively remove SO₂ from combustion gases is dry scrubbing. Dry FGD systems produce a dry by-product that is removed in the particulate control equipment, versus wet FGD systems where the by-product is a slurry collected separately from the fly ash. Various types of dry FGD systems are described below.

i. Spray Dry Absorber

The typical spray dry absorber uses a slurry of lime and water injected into the tower to remove SO₂ from the combustion gases. The towers must be designed to provide adequate contact and residence time between the exhaust gas and the slurry in order to produce a relatively dry by-product. The process equipment associated with a spray dryer typically includes an alkaline storage tank, mixing and feed tanks, an atomizer, spray chamber, particulate control device, and a recycle system. The recycle system collects solid reaction products and recycles them back to the spray dryer feed system to reduce alkaline sorbent use.

Spray dry systems are the typical dry scrubbing method in large industrial and utility boiler applications. Spray dry systems have demonstrated the ability to achieve greater than 90% SO₂ reduction on a consistent basis. The actual control efficiency depends on several factors, including the SO₂ concentration in the flue gas exhaust entering the spray dryer. Based on a maximum uncontrolled SO₂ emission rate of 1.9 lb/MMBtu, the dry spray absorber technology would consistently achieve a removal efficiency of approximately 94% and a maximum controlled emission rate of 0.12 lb/MMBtu.

ii. Dry Sorbent Injection

Dry sorbent injection involves the injection of powdered absorbent directly into the flue gas exhaust stream. Dry sorbent injection systems are simple systems, and generally require a sorbent storage tank, feeding mechanism, transfer line and blower, and an injection device. The dry sorbent is typically injected countercurrent to the gas flow. An expansion chamber is often located downstream of the injection point to increase residence time and efficiency. Particulates generated in the reaction are controlled in the systems particulate control device.

Typical SO₂ control efficiencies for a dry sorbent injection system are around 50%. The control efficiency of the dry sorbent system is lower than the control efficiency of either the wet FGD or spray dry absorber FGD.

iii. Circulating Dry Scrubber

A third type of dry scrubbing system uses a circulating fluidized bed of dry hydrated lime reagent to remove SO₂. Flue gas passes through a venturi at the base of a vertical reactor tower and is humidified by a water mist. The humidified flue gas then enters a fluidized bed of powdered hydrated lime where SO₂ is removed. The dry by-product produced by this system is similar to the spray dry absorber by-product and is routed with the flue gas to the particulate removal system. Because of the high particulate loading, the pressure drop across a fabric filter is generally unacceptable; therefore, ESPs are generally required for particulate control.

The circulating dry scrubber has limited application and has not been used on large pulverized coal boilers. Assuming that a circulating dry scrubber system could be designed for the proposed project, the anticipated SO₂ control efficiency would be similar to the control efficiency of a spray dry absorber system.

The total water use demands for a dry FGD system (for two 390-MW units) would be approximately 304.8 MMgal/year, the total sorbent feed rate for a dry FGD system would be approximately 20,664 lb/hr, and the total solid waste generation rate would be approximately 154,458 ton/yr. In addition, the dry FGD system would not generate a wastewater stream. The dry by-product that is created in a dry FGD system does not require dewatering or treatment prior to disposal.

Dry FGD also provides some control of H₂SO₄ emissions. The total emissions (from both units) of H₂SO₄ while using dry FGD would be approximately 209 tons per year.

The use of dry FGD would potentially result in visibility impacts on a more widespread basis, but would likely not result in impacts on a local basis. On a more widespread basis, the facility's modeled emissions indicate that impacts would result at Class 1 areas around the facility. Locally, the plume would be relatively dry and would not be much more visible on any one day as compared to another.

The average cost per ton of reduction was determined for dry FGD. The average cost per ton of reduction was estimated to be \$390.

The Department determined that an SO₂ emission limit of 0.12 lb/MMBtu will constitute BACT for each of the two main power boilers. Wet scrubbing does not constitute BACT for the main power boiler for a variety of reasons. Although wet lime and wet limestone scrubbing are technically feasible, the technologies can result in collateral impacts. For example, both of these technologies can result in the formation of condensable particulates and acid gases, neither of which would be controlled with the proposed particulate control (baghouse). In addition, the wet process would require additional water, which is a critical limiting factor in the area. In fact, an air cooled condenser (ACC) will be used elsewhere in the process, rather than a cooling tower, to minimize water usage. Also, the solid waste by-product from the scrubbing process would need to be managed in dewatering ponds and/or a landfill. Conversely, the Department determined that the control provided by a dry FGD system is consistent with other recently permitted similar sources and that the collateral environmental effects from using a wet FGD system are too great to justify designating that a wet FGD (with or without WESP) system constitutes BACT.

4. CO Emissions

CO is a product of incomplete combustion. In order to minimize emissions of CO, good combustion must be ensured. An ideal burner scenario designed for complete combustion would allow for maximum temperatures, maximum residence time, and enough excess air and turbulence to assure good mixing and availability of O₂. However, CO emissions vary inversely with NO_x emissions. Combustion controls designed to reduce NO_x emissions, including low excess air, reduced residence time, and lower temperatures, tend to increase the generation of CO.

Two post-combustion control systems have been identified for potential application at the proposed Roundup Power facility; thermal oxidation and catalytic oxidation. Both of these post-combustion control systems are currently used to control volatile organic compound emissions from sources in petro-chemical industry.

- a. Catalytic Oxidation - Catalytic oxidation systems are designed to oxidize CO to CO₂ in the presence of a catalyst. In refinery applications, and on gas turbine applications, catalytic oxidation systems have demonstrated CO reduction efficiencies of 80-90%. However, there are no known installations of oxidation catalysts on coal-fired power plant boilers.

Several technical issues accompany the use of catalytic oxidation as a control for a coal-fired power plant boiler. For example, sulfur compounds in the flue gas tend to deactivate the catalyst at a rapid rate. Furthermore, in a coal fired boiler, dust suspended in the exhaust gas tends to foul and poison the catalyst. Because of the catalyst fouling concern, the catalyst would have to be placed downstream of the particulate control device and the SO₂ control device. Even then, sulfur compounds and particulates remaining in the flue gas would tend to foul the catalyst.

The need to place the catalyst downstream of the SO₂ and particulate control devices creates other problems--primarily dealing with flue gas temperature. The flue gas exiting the particulate control device (baghouse) would be approximately 180°F, while the catalyst requires a minimum temperature of approximately 500°F-600°F to oxidize CO to CO₂. The exhaust gases would have to be reheated to approximately 500°-600°F for the CO oxidation to occur. Reheating the exhaust would require oil-fired heaters, which would increase overall emissions of NO_x and PM₁₀.

Finally, the conditions necessary to oxidize CO would also oxidize SO₂ to SO₃. It is estimated that as much as 30-50% of the SO₂ in the flue gas would oxidize to SO₃ as a result of the CO oxidation catalyst. SO₃ would react with moisture in the flue gas to form sulfuric acid mist in the atmosphere.

- b. Thermal Oxidation - Thermal oxidation uses heat and oxygen to convert CO to CO₂. Because no catalyst is used in a thermal oxidizer, the temperature at which the conversion takes place is much higher. Temperatures above 1500°F are required to convert CO to CO₂.

Particulate matter present in the coal-fired boiler exhaust gas would accumulate in the thermal oxidizer chamber and would plug and foul fans, ductwork, and other essential equipment. Therefore, as with catalytic oxidizers, thermal oxidizers must be located downstream of the particulate control device. The exhaust gas temperature at the baghouse outlet is typically approximately 180°F. To increase the exhaust temperature from 180°F to 1500°F requires a series of heat exchangers and a natural gas-fire furnace. Burning of additional fuel to heat the exhaust gas would increase overall emissions of NO_x, CO, and PM₁₀.

There are no known installations of thermal oxidizers on coal-fired power plants. Most thermal oxidation technology for stationary sources is utilized for the control of volatile organic emissions.

- c. Proper Boiler Design and Operation - A properly designed and operated boiler effectively minimizes CO emissions. CO formation is minimized when the boiler temperature and excess oxygen availability are adequate for complete combustion. Minimizing CO emissions is in the economical best interest of the boiler operator because CO represents unutilized energy exiting the process.

Proper boiler design and operation can minimize the generation of both CO and NO_x. The Department determined that an emission limit of 0.15 lb/MMBtu constitutes BACT for the proposed boiler. Furthermore, the Department determined that proper boiler design and operation is necessary to maintain compliance with the CO emission limit established as part of this BACT analysis. Because of the technological difficulties associated with designing an oxidation catalyst for a coal-fired boiler, and because an oxidation catalyst system has not been used on a coal-fired power plant and is not commercially available, catalytic oxidation is deemed to be technically infeasible and was eliminated from further consideration in the BACT analysis. Furthermore, because of the technical issues (need to reheat gas and burn more fuel) associated with thermal oxidation and because thermal oxidizers have not been used on coal-fired power plants or any other stationary source applications of this magnitude, the use of a thermal oxidizer was eliminated from further consideration.

5. VOC Emissions

The rate at which VOCs are emitted depends on the combustion efficiency of the boiler. Controls that are designed to reduce NO_x emissions tend to increase VOC emissions and controls that tend to reduce CO emissions tend to reduce VOC emissions. Post-combustion catalytic oxidation and thermal oxidation would generally reduce VOC emissions, but neither of these control options is considered technically feasible because they have not been practically proven on a pulverized coal unit.

The only technically feasible control option for VOC control is proper design and operation. With proper design and operation, a pulverized coal boiler will provide all of the factors to facilitate complete volatile combustion, including extended residence time, consistent high temperatures in the combustion chamber, and continuous mixing of air and fuel. Proper boiler design and operation will minimize VOC emissions and limit the generation of NO_x. Also as part of the BACT determination, the Department determined that a VOC limit of 0.0030 lb/MMBtu is appropriate.

6. Sulfuric Acid Mist Emissions

Sulfuric acid mist (H₂SO₄) is one of the PSD pollutants listed in 40 CFR 52.21. Sulfuric acid mist is typically generated when sulfuric trioxide (SO₃) in the flue gas reacts with water to form sulfuric acid. The combustion of coal will result in the formation of sulfuric acid.

Four options were analyzed for the sulfuric acid mist control technology review. The four options are summarized below.

- a. Dry FGD (Spray Dry Absorber) - Using a dry FGD system, SO₃ would react with sprayed lime in the absorber to form calcium sulfate. Because SO₃ is very reactive, approximately 90% of the SO₃ would be removed from the flue gas in the spray dry absorber and subsequent reactions in the fabric filter. The remaining 10% (5 ppm) of the SO₃ would be emitted to atmosphere and would react with water in atmosphere and precipitate out of the atmosphere as sulfuric acid.
- b. Wet FGD - Using a wet FGD system, SO₃ would enter the wet scrubbers and react with the water to form micron sized sulfuric acid droplets. Because micron sized droplets can pass through the spray levels and the mist eliminator, the droplets can be emitted as sulfuric acid mist. Although some of the droplets would react with limestone in the wet scrubber, the size of the droplets would prevent the majority of the droplets from contacting the limestone. Approximately 25% of the sulfuric acid mist droplets would be captured by this system and approximately 75% (37.5 ppm) of the sulfuric acid mist droplets would be released to atmosphere from this system.
- c. Wet FGD with WESP - While using Wet FGD, sulfuric acid mist can be further reduced by using a WESP downstream from the Wet FGD. The sulfuric acid mist would be removed from the flue gas stream as a condensable particulate in the WESP. Using WESP in conjunction with wet FGD would reduce the sulfuric acid mist emissions by approximately 90%. The remaining 10% (5 ppm) would be emitted to atmosphere.
- d. No Additional controls - The base case would result in approximately 50 ppm of sulfuric acid mist.

Roundup Power proposed and the Department agrees that dry FGD constitutes BACT for sulfuric acid mist emissions. Not only is the use of dry FGD technology feasible, but dry FGD is required as part of the SO₂ BACT analysis and will be economically feasible. Furthermore, the use of dry FGD will yield the highest sulfuric acid control of the technically feasible control options.

B. Auxiliary Boilers

In addition to the coal-fired main boilers, the Roundup Power Project will have two oil-fired auxiliary boilers. The auxiliary boilers will generate steam for heating plant buildings and for start-up of the main boilers when both of the main units are shut down. Generally, operation of the auxiliary boilers will not be necessary when either of the main boilers is operating.

As proposed, the auxiliary boilers would be designed with low NO_x burners, and would be fired with low sulfur No. 2 fuel oil. This is an inherently clean fuel, with a maximum sulfur content of 0.05% and a maximum ash content of 0.25%. Emissions from the auxiliary boilers would also be minimized by limits on the annual hours of operation of the boilers. As stated above, the primary function of the auxiliary boilers is to provide steam for start-up and plant heating when both of the main boilers are shut down. Each of the main boilers is expected to have an average annual capacity factor of approximately 90%, so operation of the auxiliary boilers should be very infrequent.

In order to estimate maximum annual emissions from the auxiliary boilers, it was assumed that during some years the auxiliary boilers might need to operate as much as 3,300 hours/year (total for both boilers). This assumption is considered very conservative, because in most years the auxiliary boilers are expected to operate much less than 3,300 hours/year. Nevertheless, limiting the hours of operation to 3,300 hours/year will reduce the potential annual emissions from the auxiliary boilers by more than 81%.

The Department determined that the use of low NO_x burners and low sulfur No. 2 fuel oil, in conjunction with the requested hourly restriction (3300 hours per rolling 12-month period), constitutes BACT for the auxiliary boilers.

C. Backup Generator

The proposed Roundup Power facility will be equipped with one 1.6-MW emergency generator fired with low sulfur No. 2 fuel oil. As discussed above, low sulfur No. 2 fuel oil is an inherently clean fuel. Furthermore, the emergency generator would be used only during an interruption of the electrical power supply to the site and for short test periods. It is estimated that the emergency generator would be fired for a maximum of 200 hours per year.

The Department determined that the use of low sulfur No. 2 fuel oil, in conjunction with the requested hourly restriction (200 hours per rolling 12-month period), constitutes BACT for the emergency generator.

D. Material Handling Emission Sources - Particulate Emissions

The proposed Roundup Power facility would consist of numerous sources of particulate emissions (transfer points, fugitive sources, and storage piles). Control options for each of the sources have been analyzed to determine the best available control technology.

1. Transfer Points

Transfer points include railcar/truck loading and unloading, conveyor to conveyor drops, material transfers from reclaim hoppers to conveyors, and transfers from conveyors to storage silos. Particulate emissions would be generated as the material drops through the transfer point. The potential to generate particulate emissions at a transfer point is a function of the rate at which the material flows through the transfer point, the material's particle size, and the material's moisture content.

Based on EPA's emission factor for predicting particulate emissions from a transfer point (which factors in wind speed, material particle size distribution, and moisture content), potential emissions from a transfer point can be reduced by decreasing the speed at which the material is transferred or increasing the aggregate's moisture content by watering or chemical wetting agents. Transfer point emissions may be further reduced by enclosing the transfer operations within a structure and exhausting the structure through a particulate control device.

The Department determined that the use of a combination of dust suppression systems, enclosures, and baghouses to control particulate matter emissions from coal handling transfer points constitutes BACT. Furthermore, the Department determined that the lime needs to be handled/transferred using a pneumatic system and that a bin exhaust filter needs to be used on each of the two lime storage silos. Roundup Power will be required to ensure that all fly ash is transferred using a vacuum-pressure system. The Department also determined that all baghouses/bin vents used to control emissions from the material handling system need to be capable of maintaining a maximum outlet emission rate of 0.010 grain/dscf.

2. Fugitive Dust Sources

Fugitive particulate emissions from coal, lime, and fly ash handling can occur at several points in the storage cycle, including material loading onto a storage pile, disturbances by strong wind currents, and loadout from the pile. Based on AP-42 equations that predict the potential particulate emissions from an aggregate storage pile, the generation of fugitive dust from material handling is a function of the following variables:

- a. **Threshold Friction Velocity.** Threshold friction velocity is a characteristic of the storage pile that relates to the wind speed necessary to remove dust particles from the storage pile. The higher the threshold friction velocity the higher the wind speed needed to generate dust. Threshold friction velocity is a function of the material's erosion potential, which in turn is a function of the material's size distribution and moisture content. Increasing the material's particle size or moisture content would decrease its erosion potential and increase the storage pile's threshold friction velocity.
- b. **Wind Speed.** Wind speed at the face of the storage pile must exceed the threshold friction velocity in order to generate dust.
- c. **Frequency of Disturbance.** Emissions generated by wind erosion are dependent on the frequency of disturbance of the erodible surface of the storage pile. Each time that a surface is disturbed, its erosion potential is restored. A disturbance is defined as an action that results in the exposure of fresh surface material. On a storage pile, this would occur whenever material is added to or removed from the old surface.

The potential for fugitive emissions from a storage pile can be reduced by reducing the material's erosion potential, reducing the wind speed at the face of the storage pile, and/or reducing the frequency of storage pile disturbances. Watering, or the use of chemical wetting agents can reduce the erosion potential of a storage pile. Reducing the maximum wind speed that impacts the face of the storage pile can reduce wind erosion. Technologies that may feasibly reduce wind speed include enclosures and wind breaks around the storage pile.

Several control technologies may be used to reduce particulate emissions from material handling transfer points. Particulate matter control options considered for the Roundup Power Project include dust suppression systems, enclosed transfer points, pneumatic lines, and baghouse filters.

Spray dust suppression systems consist of a fine water mist that is sprayed onto the aggregate as it moves through the transfer point. The water mist effectively knocks down particulates before they are emitted to the atmosphere. Based on manufacturer studies and literature, it is predicted that a properly operating spray dust suppression system can reduce potential particulate emissions from a material transfer point by approximately 95%.

Locating transfer points within an enclosed building would also reduce particulate emissions. Dust generated from the transfer point would be contained within the building. Depending on air movement within the enclosure, and the material's particle size distribution, dust generated from the transfer point would either settle out in the enclosure or be emitted with the building's exhaust. If transfer operations within an enclosure are such that significant dust will be exhausted, a dust collection system (e.g., baghouse) can be used at the building's emission point to reduce particulate emissions. A baghouse can reduce particulate emissions from the transfer points by greater than 99.5% on a consistent basis, and can be designed to meet an outlet loading of 0.010 grain/dscf under all inlet loading conditions.

Separate material handling systems will be designed to handle lime and fly ash. Lime will be handled/transferred using a pneumatic system, and fly ash will be transferred using a vacuum/pressure system. A complete description of the proposed material handling systems, identifying the coal, lime, and fly ash transfer points, emission points, and control systems is included in Section 2 of the permit application.

3. Active Storage Piles

Totally enclosing the active storage pile is not practical because of the activity at the active storage pile (i.e., bulldozing and adding coal to the pile with a radial stacker). However, active coal storage piles have been located within coal storage sheds. Storage sheds are designed such that coal is delivered to the active storage pile by way of a conveyor system. Coal in the storage shed is funneled to the bottom of the shed where large rotary plows scrape the coal onto conveyors to be transported to the boilers. A storage shed would eliminate wind erosion from the active storage pile, however, particulates would still be generated by the rotary plows and from adding coal to the storage pile.

Particulates generated from the rotary plows and from adding coal to the active storage pile may be emitted with the storage shed's ventilation exhaust. It is estimated that total particulates from the active storage pile would be reduced by approximately 98% if the active storage pile is located within a storage shed.

Roundup Power is proposing to control particulate emissions from the active storage pile by installing a wind fence and using dust suppression sprays on coal as it is added to the pile. It is predicted that this combination of control strategies would reduce potential particulate emissions from the active storage pile by 98%.

4. Inactive Storage Pile

Several design and operational techniques exist to control fugitive emissions from an aggregate storage pile. The effectiveness of each control system would depend on the type of material stored, the size and shape of the pile, and how often the storage pile is disturbed. Fugitive emission control options considered for the Roundup Power Project are described below.

Totally enclosing a material storage pile that is infrequently disturbed may be a technically feasible option to control fugitive emissions. It may be possible to construct a structure covering approximately 100,000 square feet to cover the inactive coal storage pile. The structure would have to be designed to allow coal to be added and removed from the pile. The most economical structure available to cover a storage pile would likely be an air-inflated building. Although enclosing the inactive storage pile may be technically feasible, the Department is not aware of any pulverized coal facilities with covered inactive storage piles, and technical issues may arise which would preclude covering the entire storage pile. For example, heat generated within the storage pile may not be effectively dissipated thus creating a fire hazard.

Enclosing the inactive storage pile would reduce wind speeds at the surface of the storage pile, essentially eliminating emissions generated from wind erosion. Particulates would only be generated when the storage pile is disturbed (e.g., material is either added to or removed from the pile). Particulates generated when the pile is disturbed may be emitted to the atmosphere with the enclosure's exhaust system. Assuming that particulates would only be generated when the inactive storage pile is disturbed, it is predicted that totally enclosing the inactive storage pile would reduce potential particulate emissions by approximately 99.5%.

A wind fence may be a feasible option to reduce the wind speed at the surface of a storage pile and thus reduce particulate emissions. Wind tunnels and field experiments have shown that windbreaks produce large areas of reduced wind speed in their line. A properly designed windbreak placed upwind of a oval, flat-topped storage pile can

produce wind speed reduction factors of 20 - 60% over the surface of the pile. To be effective, the windbreak should be at least as high as the pile and as long as the pile base. Windbreaks of height and/or length less than that of the pile are less effective. Based on published literature, and AP-42 emission factors, it is predicted that a windbreak would reduce potential particulate emissions by 90% for each wind event. Reducing the windspeed reduces the number of events in which the coal threshold friction velocity is exceeded. Therefore, the number of emission events per year is reduced and the annual emission reduction is 98%.

Dust suppression sprays can be used on storage piles to reduce particulate emissions. Dust suppression sprays can consist of a water spray or water mixed with surfactants to increase wetting and/or produce a residual crust over the storage pile. Dust suppression sprays reduce the material's erosion potential, thus increasing the threshold friction velocity. Therefore, a higher wind speed would be required to generate dust from the storage pile. Compacting the storage pile can further reduce the pile's erosion potential. It is estimated that treating material storage piles which are not frequently disturbed (e.g., the inactive coal pile) with compaction and a dust suppression spray can reduce total particulate emissions from aggregate storage operations by up to 90%.

Using a dust suppression spray consisting of water and/or a surfactant to increase wetting on the active storage pile would not be as effective, and would require more frequent application of the suppressant because disturbing the pile would restore its erosion potential. It is projected that application of a dust suppression spray to material being added to the active storage pile will reduce potential fugitive emissions from the pile by 80%.

Roundup Power is proposing, and the Department agrees, that particulate emissions from the inactive storage pile should be controlled by installing a wind fence and using dust suppression sprays and pile compaction. It is predicted that this combination of control strategies will reduce potential particulate emissions from the inactive storage pile by 98%.

The control options selected have controls and control costs comparable to other recently permitted similar sources and are capable of achieving the appropriate emission standards.

IV. Emission Inventory

Source	PM ₁₀ (tpy)	SO ₂ (tpy)	NO _x (tpy)	VOC (tpy)	CO (tpy)	HAPs (tpy)	Pb (tpy)
Main Boiler #1 (MP-1)	245.5	1964.1	1145.7	49.5	2455.1	45.09	0.10
Main Boiler #2 (MP-2)	245.5	1964.1	1145.7	49.5	2455.1	45.09	0.10
Auxiliary Boiler #1 (AB-1)	1.38	5.43	16.61	0.17	3.46	0.15	0.00
Auxiliary Boiler #2 (AB-2)	1.38	5.43	16.61	0.17	3.46	0.15	0.00
Backup Generator (BG-1)	0.05	0.08	4.42	0.10	0.10	0.00	0.00
Coal Handling	8.29	---	---	---	---	---	---
Lime Handling	1.06	---	---	---	---	---	---
Fly Ash Handling	5.26	---	---	---	---	---	---
Totals	508.41	3939.1	2329.0	99.45	4917.2	90.48	0.19

Main Power Boiler #1 (MP-1)

Fuel: Pulverized bituminous coal
 Gross Plant Output = 390,100 kW
 Net Plant Output = 350,172 kW
 Primary Fuel Feed Rate = 188 ton/hr

Full Load Heat Input to Boiler = 3737 MMBtu/hr
Sorbent Feed Rate = 10,332 lb/hr (45,255 ton/yr)
Annual Capacity Factor = 100% per year

PM₁₀ Emissions

Emission Factor (uncontrolled) = 8.16 lb/MMBtu
Emission Factor (controlled) = 0.015 lb/MMBtu (permit condition)
Calculation: 0.015 lb/MMBtu * 3737 MMBtu/hr = 56.055 lb/hr
56.055 lb/hr * 8760 hr/yr * 0.0005 ton/lb = 245.5 ton/yr

SO_x Emissions

Emission Factor (uncontrolled) = 1.90 lb/MMBtu
Emission Factor (controlled) = 0.12 lb/MMBtu (permit condition)
Calculation: 0.12 lb/MMBtu * 3737 MMBtu/hr = 448.44 lb/hr
448.44 lb/hr * 8760 hr/yr * 0.0005 ton/lb = 1964.2 ton/yr

NO_x Emissions

Emission Factor (uncontrolled) = 31 lb/ton (AP-42, Table 1.1-3, 9/98)
Emission Factor (unc.) = 31 lb/ton * 188 ton/hr * 1hr/3737 MMBtu = 1.56 lb/MMBtu
Emission Factor (controlled) = 0.07 lb/MMBtu (permit condition)
Calculation: 0.07 lb/MMBtu * 3737 MMBtu/hr = 261.59 lb/hr
261.59 lb/hr * 8760 hr/yr * 0.0005 ton/lb = 1145.8 ton/yr

VOC Emissions

Emission Factor (uncontrolled) = 0.0030 lb/MMBtu (permit condition)
Calculation: 0.0030 lb/MMBtu * 3737 MMBtu/hr = 11.21 lb/hr
11.21 lb/hr * 8760 hr/yr * 0.0005 ton/lb = 49.1 ton/yr

CO Emissions

Emission Factor (uncontrolled) = 0.15 lb/MMBtu (permit condition)
Calculation: 150 lb/MMBtu * 3737 MMBtu/hr = 261.59 lb/hr
261.59 lb/hr * 8760 hr/yr * 0.0005 ton/lb = 1145.8 ton/yr

HAP Emissions

Total HAP emissions were determined for "unwashed coal." A summary of the calculations for the HAP emissions is contained in permit application #3182-00 (in Appendix B). The total HAP emissions are the sum of the total emissions from several tables in the appendix. HAPS = 45.09 ton/yr

Main Power Boiler #2 (MP-2)

Fuel: Pulverized bituminous coal
Gross Plant Output = 390,100 kW
Net Plant Output = 350,172 kW
Primary Fuel Feed Rate = 188 ton/hr
Full Load Heat Input to Boiler = 3737 MMBtu/hr
Sorbent Feed Rate = 10,332 lb/hr (45,255 ton/yr)
Annual Capacity Factor = 100% per year

PM₁₀ Emissions

Emission Factor (uncontrolled) = 8.16 lb/MMBtu
Emission Factor (controlled) = 0.015 lb/MMBtu (permit condition)
Calculation: 0.015 lb/MMBtu * 3737 MMBtu/hr = 56.055 lb/hr
56.055 lb/hr * 8760 hr/yr * 0.0005 ton/lb = 245.5 ton/yr

SO_x Emissions

Emission Factor (uncontrolled) = 1.90 lb/MMBtu
Emission Factor (controlled) = 0.12 lb/MMBtu (permit condition)
Calculation: $0.12 \text{ lb/MMBtu} * 3737 \text{ MMBtu/hr} = 448.44 \text{ lb/hr}$
 $448.44 \text{ lb/hr} * 8760 \text{ hr/yr} * 0.0005 \text{ ton/lb} = 1964.2 \text{ ton/yr}$

NO_x Emissions

Emission Factor (uncontrolled) = 31 lb/ton (AP-42, Table 1.1-3, 9/98)
Emission Factor = $31 \text{ lb/ton} * 188 \text{ ton/hr} * 1\text{hr}/3737 \text{ MMBtu} = 1.56 \text{ lb/MMBtu}$
Emission Factor (controlled) = 0.07 lb/MMBtu (permit condition)
Calculation: $0.07 \text{ lb/MMBtu} * 3737 \text{ MMBtu/hr} = 261.59 \text{ lb/hr}$
 $261.59 \text{ lb/hr} * 8760 \text{ hr/yr} * 0.0005 \text{ ton/lb} = 1145.8 \text{ ton/yr}$

VOC Emissions

Emission Factor (uncontrolled) = 0.0030 lb/MMBtu (permit condition)
Calculation: $0.0030 \text{ lb/MMBtu} * 3737 \text{ MMBtu/hr} = 11.21 \text{ lb/hr}$
 $11.21 \text{ lb/hr} * 8760 \text{ hr/yr} * 0.0005 \text{ ton/lb} = 49.1 \text{ ton/yr}$

CO Emissions

Emission Factor (uncontrolled) = 0.15 lb/MMBtu (permit condition)
Calculation: $150 \text{ lb/MMBtu} * 3737 \text{ MMBtu/hr} = 261.59 \text{ lb/hr}$
 $261.59 \text{ lb/hr} * 8760 \text{ hr/yr} * 0.0005 \text{ ton/lb} = 1145.8 \text{ ton/yr}$

HAP Emissions

Total HAP emissions were determined for "unwashed coal." A summary of the calculations for the HAP emissions is contained in permit application #3182-00 (in Appendix B). The total HAP emissions are the sum of the total emissions from several tables in the appendix. HAPS = 45.09 ton/yr

Auxiliary Boiler #1 (AB-1)

Fuel = No.2 Fuel Oil
Boiler Heat Input with Margin = 117 MMBtu/hr
Fuel Consumption = 6014 lb/hr
Total Fuel Consumption = 823 gal/hr
Annual Fuel Consumption = 1,383,000 gal
Hours of operation = 3360 hours per year combined (\cong 1680 hours)
Sulfur in Fuel = 0.5%

PM₁₀ Emissions

Emission Factor = 2 lb/1000 gal (AP-42, Table 1.3-1, 9/98)
Calculation: $(2/1000) \text{ lb/gal} * 823 \text{ gal/hr} = 1.646 \text{ lb/hr}$
 $1.646 \text{ lb/hr} * 1680 \text{ hr/yr} * 0.0005 \text{ ton/lb} = 1.38 \text{ ton/yr}$

SO_x Emissions

Emission Factor = $157 * S \text{ lb/1000 gal}$ (AP-42, Table 1.3-1, 9/98)
Calculation: $(157(0.5)/1000) \text{ lb/gal} * 823 \text{ gal/hr} = 64.61 \text{ lb/hr}$
 $64.61 \text{ lb/hr} * 1680 \text{ hr/yr} * 0.0005 \text{ ton/lb} = 54.3 \text{ ton/yr}$

NO_x Emissions

Emission Factor = 24 lb/1000 gal (AP-42, Table 1.3-1, 9/98)
Calculation: $(24/1000) \text{ lb/gal} * 823 \text{ gal/hr} = 19.75 \text{ lb/hr}$
 $19.75 \text{ lb/hr} * 1680 \text{ hr/yr} * 0.0005 \text{ ton/lb} = 16.60 \text{ ton/yr}$

VOC Emissions

Emission Factor = 0.252 lb/1000 gal (AP-42, Table 1.3-1, 9/98)
Calculation: $(0.252/1000) \text{ lb/gal} * 823 \text{ gal/hr} = 0.207 \text{ lb/hr}$
 $0.207 \text{ lb/hr} * 1680 \text{ hr/yr} * 0.0005 \text{ ton/lb} = 0.17 \text{ ton/yr}$

CO Emissions

Emission Factor = 5 lb/1000 gal (AP-42, Table 1.3-1, 9/98)
Calculation: $(5/1000) \text{ lb/gal} * 823 \text{ gal/hr} = 4.12 \text{ lb/hr}$
 $4.12 \text{ lb/hr} * 1680 \text{ hr/yr} * 0.0005 \text{ ton/lb} = 3.46 \text{ ton/yr}$

HAP Emissions

Emission Factors (AP-42, Table 3.4-3, Table 3.4-4, 10/96)
Calculation: See Permit Application #3182-00, Appendix B = 0.15 ton/yr

Auxiliary Boiler #2 (AB-2)

Fuel = No.2 Fuel Oil
Boiler Heat Input with Margin = 117 MMBtu/hr
Fuel Consumption = 6014 lb/hr
Total Fuel Consumption = 823 gal/hr
Annual Fuel Consumption = 1,383,000 gal
Hours of operation = 3360 hours per year combined (\cong 1680 hours)
Sulfur in Fuel = 0.5%

PM₁₀ Emissions

Emission Factor = 2 lb/1000 gal (AP-42, Table 1.3-1, 9/98)
Calculation: $(2/1000) \text{ lb/gal} * 823 \text{ gal/hr} = 1.646 \text{ lb/hr}$
 $1.646 \text{ lb/hr} * 1680 \text{ hr/yr} * 0.0005 \text{ ton/lb} = 1.38 \text{ ton/yr}$

SO_x Emissions

Emission Factor = 157*S lb/1000 gal (AP-42, Table 1.3-1, 9/98)
Calculation: $(157(0.5)/1000) \text{ lb/gal} * 823 \text{ gal/hr} = 64.61 \text{ lb/hr}$
 $64.61 \text{ lb/hr} * 1680 \text{ hr/yr} * 0.0005 \text{ ton/lb} = 54.3 \text{ ton/yr}$

NO_x Emissions

Emission Factor = 24 lb/1000 gal (AP-42, Table 1.3-1, 9/98)
Calculation: $(24/1000) \text{ lb/gal} * 823 \text{ gal/hr} = 19.75 \text{ lb/hr}$
 $19.75 \text{ lb/hr} * 1680 \text{ hr/yr} * 0.0005 \text{ ton/lb} = 16.60 \text{ ton/yr}$

VOC Emissions

Emission Factor = 0.252 lb/1000 gal (AP-42, Table 1.3-1, 9/98)
Calculation: $(0.252/1000) \text{ lb/gal} * 823 \text{ gal/hr} = 0.207 \text{ lb/hr}$
 $0.207 \text{ lb/hr} * 1680 \text{ hr/yr} * 0.0005 \text{ ton/lb} = 0.17 \text{ ton/yr}$

CO Emissions

Emission Factor = 5 lb/1000 gal (AP-42, Table 1.3-1, 9/98)
Calculation: $(5/1000) \text{ lb/gal} * 823 \text{ gal/hr} = 4.12 \text{ lb/hr}$
 $4.12 \text{ lb/hr} * 1680 \text{ hr/yr} * 0.0005 \text{ ton/lb} = 3.46 \text{ ton/yr}$

HAP Emissions

Emission Factors (AP-42, Table 3.4-3, Table 3.4-4, 10/96)
Calculation: See permit application #3182-00, Appendix B = 0.15 ton/yr

Backup Generator (BG-1)

Fuel = No.2 Fuel Oil

Size = 2336.2 Hp

Max. Sulfur in Fuel = 0.05%

Fuel Consumption = 111.5 gal/hr

Hours of operation = 200 hours per year

PM₁₀ Emissions

Emission Factor = 0.52 lb/hr (Manufacturer's Data)

Calculation: 0.52 lb/hr * 200 hr/yr * 0.0005 ton/lb = 0.05 ton/yr

SO_x Emissions

Emission Factor = 0.00355 lb/gal (Mass Balance - Allowable Sulfur in Fuel)

Calculation: 0.00355 lb/gal * 111.5 gal/hr = 0.3958 lb/hr

0.3958 lb/hr * 200 hr/yr * 0.0005 tons/lb = 0.04 ton/yr

NO_x Emissions

Emission Factor = 44.22 lb/hr (Manufacturer's Data)

Calculation: 44.22 lb/hr * 200 hr/yr * 0.0005 ton/lb = 4.42 ton/yr

VOC Emissions

Emission Factor = 0.98 lb/hr (Manufacturer's Data)

Calculation: 0.98 lb/hr * 200 hr/yr * 0.0005 ton/lb = 0.10 ton/yr

CO Emissions

Emission Factor = 0.95 lb/hr (Manufacturer's Data)

Calculation: 0.95 lb/hr * 200 hr/yr * 0.0005 ton/lb = 0.10 ton/yr

HAP Emissions

Emission Factors (AP-42, Table 3.4-3, Table 3.4-4, 10/96)

Calculation: See Permit Application #3182-00, Appendix B = 0.00 ton/yr

V. Existing Air Quality

As part of complying with the PSD program requirements, Roundup Power was required to conduct on-site pre-monitoring for PM₁₀ and SO₂, because air modeling showed the concentrations of these pollutants to exceed the levels identified in ARM 17.8.818(7). Roundup Power requested to use, and the Department agreed to accept, ambient PM₁₀ data that was collected by Meridian Minerals Company from March 1989 through March 1992. The measured PM₁₀ values yielded an annual average PM₁₀ concentration of 9 µg/m³, and the maximum measured 24-hour concentration was 53 µg/m³ (compared to standards of 50 µg/m³ for the annual average, and 150 µg/m³ for the 24-hour average).

Ambient monitoring was conducted by Roundup Power to measure the concentration of SO_x in the project area. Roundup Power began collecting ambient SO_x data on January 1, 2002. Based upon the data collected so far, the amount of SO₂ in the immediate area of the project facility is relatively low (highest measured 1-hour concentration was 16 ppb, highest measured 3-hour concentration was 10 ppb, highest measured 24-hour concentration was 3 ppb). All of the measured concentrations were very low in comparison to the applicable Montana and Federal ambient air quality standards.

Roundup Power also elected to conduct ambient monitoring to measure the concentration of NO₂ in the project area. Roundup Power began collecting ambient NO₂ data on January 1, 2002. Based upon the data collected so far, the amount of NO₂ in the immediate area of the project facility is relatively low (highest measured 1-hour concentration was 8 ppb for NO₂). The measured concentrations were very low in comparison to the applicable 1-hour Montana ambient air quality standards.

Baseline monitoring was not conducted for any other air pollutants. The proposed project area is considered to be in attainment of all air quality standards.

VI. Ambient Air Impact Analysis

The Department determined, based on ambient air modeling, that the impact from this permitting action will be minor. The Department believes the proposed project will not cause or contribute to a violation of any ambient air quality standard.

VII. Taking or Damaging Implication Analysis

As required by 2-10-105, MCA, the Department conducted a private property taking and damaging assessment and determined there are no taking or damaging implications.

VIII. Environmental Assessment

A Draft Environmental Impact Statement is being prepared for this project by the Department.

Permit Analysis Prepared By: Dan Walsh
Date: 08/08/02

APPENDIX B DETAILED CUMULATIVE VISIBILITY AND PSD CLASS I INCREMENT ANALYSES

Cumulative Class I Increment Impacts

Since the predicted Class I increment impacts from the Project were above the Prevention of Significant Deterioration (PSD) Class I significance levels (proposed by EPA but never formally adopted), a cumulative Class I -increment analysis was conducted. There are three mandatory Class I areas within 200 kilometers (km) of the Project: Yellowstone National Park (YNP), UL Bend Wilderness (UL Bend), and North Absaroka Wilderness (NAW). The Northern Cheyenne Reservation (NCR) is a nonmandatory Class I area. Because these Class I areas are all located more than 50 kilometers from the site, CALPUFF modeling was used to assess the cumulative impacts on the Class I areas. The CALPUFF modeling protocol is detailed in the air quality permit application (Bull Mountain Development Company, LLC., 2002b).

Off-site Emitting Sources for Class I Analysis

The off-site emitting sources included in the Class I cumulative increment analysis are presented in Table B-1.

Table B-1 Emissions for Off-site Emitting Sources in Class I Cumulative Increment Analysis

Source	SO ₂ Emissions (lbs/hr)	NO _x Emissions (lbs/hr)	PM ₁₀ Emissions (lbs/hr)
Graymont Western Lime, Townsend, MT			
Kiln #1	63.5	89.8	20.8
Kiln #2	63.5	100	20.8
Rocky Mountain Generation, Hardin, MT			
Main Stack	195.6	117.4	19.56
Yellowstone Energy Limited Partnership, Billings, MT			
Main Stack	0	319	1.21
Colstrip Energy Limited Partnership, Colstrip, MT			
Main Stack	16.32	328	6.4
PPL Units #3 and #4, Colstrip, MT			
Unit #3, 3-hour	2136.5	5301	379
Unit #4, 3-hour	2136.5	5301	379
Unit #3, 24-hr	1363	5301	379
Unit #4, 24-hr	1363	5301	379
Sources in Park and Big Horn Counties, WY			
Williston Basin, EB	0	38.1	0
Colorado Inter. EB	0	34.2	0
Dakota Coal, Frannie	0.75	28.8	0

Source: Bull Mountain Development Company No 1 LLC., 2002f

PSD Class I Increment Impacts

A cumulative Class I increment analysis was performed since Class I increment impacts from Project, by itself, were greater than PSD Class I significance levels (the proposed, but not adopted PSD significance levels are 4% of the Class I increments). The CALPUFF modeling results in Table B-2 show the impacts for the cumulative PSD Class I increment analysis. This analysis includes impacts from all PSD-increment consuming sources in the area, including PPL Colstrip Units #3 and #4.

Table B-2: Cumulative Analysis PSD Class I Increments

Pollutant	Average Period	YNP Impacts ($\mu\text{g}/\text{m}^3$)	UL Bend Impacts ($\mu\text{g}/\text{m}^3$)	NAW Impacts ($\mu\text{g}/\text{m}^3$)	NCR Impacts ($\mu\text{g}/\text{m}^3$)	PSD Class I Increment ($\mu\text{g}/\text{m}^3$)	PSD Class I Sig. Level ($\mu\text{g}/\text{m}^3$)
NO ₂	Annual	0.0005	0.009	0.0009	1.248	2.5	0.1
SO ₂	Annual	0.013	0.037	0.015	0.50	2	0.08
	24-hour ^a	0.55	0.78	0.58	6.64 ^b	5	0.2
	3-hour ^a	1.80	3.08	1.77	38.18 ^b	25	1.0
PM ₁₀	Annual	0.005	0.012	0.006	0.139	4	0.16
	24-hour ^a	0.17	0.31	0.18	2.25	8	0.32

Source: Memo to Dan Walsh, DEQ from Diane Lorenzen, P.E., 2002b

^aBased on High Second High Impact

^bPrior to undertaking the cumulative impact analysis, MDEQ informed the Proponent that exceedances of the short-term SO₂ Class I increments had been previously modeled at receptors on the NCR.

The cumulative modeled impacts in the above table show that the 24-hr and 3-hr SO₂ Class I increments at YNP, NAW, and UL Bend are above the PSD Class I significance levels but below the Class I increments. Therefore, these predicted impacts would be considered moderate. All of the other modeled impacts at these Class I areas are below the PSD Class I significance levels. Therefore, the predicted impacts would be considered low.

The cumulative modeled impacts, as outlined in Table B-2, predict that the 24-hr and 3-hr SO₂ Class I increments at the NCR are exceeded. The modeling results indicate the major contributors to these predicted exceedances are PPL Colstrip Units #3 and #4. During any predicted exceedance shown by the model, the Project is not a significant contributor (i.e., Project impacts are below the PSD Class I significance level). Table B-3 and Table B-4 show the Project's highest impacts at the receptors where the 3-hr and 24-hr SO₂ Class I increments, respectively, are exceeded.

Table B-3 Project Contributions to Predicted SO₂ 3-hr Class I Increment Exceedances on the Northern Cheyenne Reservation

Receptor Number	Receptor Location		Date of Impact		Cumulative Impact (µg/m ³)	Project Impact at Receptor		
	Lambert Conf. E. (km.)	Lambert Conf. N. (km.)				Date and Time of Impact		1st / 2nd High Impact (µg/m ³)
			Day	Start Hour		Day	Start Hour	
271	224.807	24.444	46	1200	38.18	275	0600	0.95
						302	1200	0.89
272	226.732	24.501	63	1200	36.80	336	1200	0.97
						275	0600	0.96
269	220.957	24.331	260	1200	36.31	275	0600	0.99
			178	1200	35.61	115	0600	0.93
			63	1200	32.24			
268	219.032	24.274	260	1200	35.37	275	0600	1.01
			178	1200	33.56	115	0600	0.96
			63	1200	25.91			
270	222.882	24.388	178	1200	31.59	275	0600	0.97
			46	1200	30.89	302	1200	0.91
273	228.657	24.558	63	1200	30.38	336	1200	1.06
						275	0600	0.98
267	217.152	24.176	178	1200	26.26	275	0600	0.96
			63	1500	25.71	302	1200	0.94
266	216.157	23.222	63	1500	25.51	302	1200	0.94

Source: Memo to Dan Walsh, DEQ from Diane Lorenzen, P.E., 2002b

Table B-4 Project Contributions to Predicted SO₂ 24-hr Class I Increment Exceedances on the Northern Cheyenne Reservation

Receptor Number	Receptor Location		Date of Impact		Cumulative Impact (µg/m ³)	Project Impact at Receptor		
	Lambert Conf. E. (km.)	Lambert Conf. N. (km.)				Date of Impact		Project High Impact (µg/m ³)
			Day	Start Hours		Day	Start Hours	
268	219.032	24.274	363	00 - 23	6.64	363	00 - 23	0.05
			189	00 - 23	5.34	189	00 - 23	0.03

Source: Memo to Dan Walsh, DEQ from Diane Lorenzen, P.E., 2002b

Cumulative impacts at the NCR, with respect to the 24-hr and 3-hr SO₂ PSD increments, are considered high, but the Project's contributions to the exceedances are below the PSD Class I significance levels. Therefore, the Project's contributions to the exceedances on the NCR are considered low during the times of exceedances. The annual modeled SO₂ impacts at the NCR are above the PSD Class I significance level but below the increment. Therefore, the predicted cumulative impacts with respect to the Class I increment are considered moderate.

Cumulative Visibility Analysis

As part of assessing air quality impacts of the Project in combination with impacts of other major sources in the region, a cumulative visibility analysis was completed. The focus of the cumulative visibility analysis was on impacts to PSD Class I areas in the Project vicinity (i.e., YNP, UL Bend, NAW, and NCR).

The Federal Land Managers Air Quality Related Values Workshop (FLAG) Guidance document (December 2000) indicates that a cumulative visibility analysis is expected when an individual source shows impacts that exceed a 5% change in light extinction. The Project exceeded this criteria in three PSD Class I areas (YNP, NAW and UL Bend), so a cumulative impacts analysis is expected. The NCR is not a mandatory PSD Class I area (not designated by the Federal Clean Air Act), so a visibility analysis is not required by regulation; however, results of visibility modeling on the NCR are provided in this Appendix.

Procedures for conducting a cumulative visibility analysis are described in Section D.2 of the FLAG Guidance document (U.S. Forest Service, et. al., 2000). In this case, several alternate approaches to determining cumulative visibility impacts from distant sources have been applied as follows:

- Scenario #1: The proponent used a visibility baseline at year 1996 and modeled emissions from PSD sources proposed, built or with emissions since that date. Between 1987 and 1997, the US Forest Service and National Park Service started collecting aerosol and relative humidity background data at various PSD Class I areas located in the western U.S. as part of the Interagency Monitoring of Protected Visual Environments (IMPROVE) monitoring program. Natural visibility extinction coefficients listed in the FLAG document for western U.S. Class I areas are reasonably representative of baseline conditions existing during the first ten years of the IMPROVE monitoring program. Therefore, 1996 was assumed to be the visibility baseline date for determining which background sources should be included in the cumulative Class I visibility analysis (m^{emo} to Dan Walsh, DEQ, from Diane Lorenzen, P.E., 2002). Emissions from major sources or major modifications that were permitted since 1996 were included in the CALPUFF modeling.
- Scenario #2: The Federal Land Managers (FLM) have asserted that a cumulative analysis must consider all major source and major modification emissions increases permitted after the PSD baseline date of January 6, 1975. Emissions increases (but not decreases) from the PSD sources permitted since 1975 were included in the CALPUFF modeling conducted by the FLMs.
- Scenario #3: In response to the FLM position on baseline, the proponent has completed additional CALPUFF modeling to predict cumulative visibility impacts from all

major sources and major modifications, including both emissions increases and decreases, since the PSD baseline date of January 6, 1975. This analysis predicts the aggregate visibility impacts of source emissions changes by combining both positive and negative predictions of visibility impact (change in light extinction or % delta b_{ext}) into a cumulative result.

The following sections discuss the results of cumulative visibility modeling with each scenario.

Scenario #1: Cumulative Visibility Modeling Results

Emissions sources included in Scenario #1 are listed in Table B-1; however, Graymont, Colstrip Energy Limited Partnership, and Colstrip Units 3 & 4 were permitted before the 1996 baseline date and are not included in the cumulative analysis. Results generated by application of Scenario #1, incorporating emissions since 1996, are given in Table B-5. The table summarizes the daily results of the cumulative visibility impact analysis on the Class I areas and it provides the Project's contribution during that day.

Table B-5 The Project and Cumulative Visibility Modeling Results with 1996 Baseline

Date	Receptor Number	Cumulative Change in Light Extinction (%)	Receptor Number	Change in Light Extinction from the Project (%)
Yellowstone National Park				
March 6	1	14.67	234	13.03
July 21	214	12.07	214	9.63
January 16	33	10.07	33	8.22
September 29	178	9.27	183	7.14
March 24	214	8.91	214	5.81
July 20	39	6.92	34	5.59
January 17	33	6.85	33	5.66
April 6	214	6.13	214	6.03
October 7	33	6.13	33	5.31
September 19	33	6.07	--	<5.0
June 16	33	5.90	--	<5.0
February 14	113	5.73	--	<5.0
September 20	156	5.69	--	<5.0

Date	Receptor Number	Cumulative Change in Light Extinction (%)	Receptor Number	Change in Light Extinction from the Project (%)
May 13	33	5.20	--	<5.0
May 12	57	5.06	--	<5.0

UL Bend Wilderness

February 17*	243	9.95	243	7.93
February 18	243	9.75	243	6.83
August 27	243	8.30	243	6.39
February 16	243	6.62	243	6.49
December 11	243	5.62	243	<5.0

North Absaroka Wilderness

January 16	349	13.65	349	11.07
March 6	349	10.62	349	7.29
January 17	349	9.52	349	7.68
June 16	349	7.90	--	<5.0
July 20	350	7.36	350	6.15
October 7	349	6.78	349	5.49
September 19	349	6.60	350	<5.0
September 29	350	5.95	--	5.30
May 13	349	5.29	--	<5.0
March 23	349	5.27	--	<5.0
May 12	350	5.26	--	<5.0
August 12	349	5.25	--	<5.0

Source: Memo to Dan Walsh, DEQ from Diane Lorenzen, P.E., 2002b

Note: Relative Humidity (RH) Factor Estimation Method: Hourly CALMET Database RH Data (Maximum RH of 98% for Particle Growth)

The maximum impacts predicted by the cumulative visibility analysis in Scenario #1 are higher than 10% at YNP and NAW. Therefore, the predicted impacts would be considered high.

Cumulative impacts predicted at the UL Bend are below 10% but above the *de minimis* level. Therefore, the predicted impacts would be considered moderate.

Scenario #2: Cumulative Visibility Modeling Results

Impacts determined in the Scenario #2 cumulative visibility modeling conducted by the FLMs are given in Table B-6. The FLM modeling included the facilities listed in Table B-1 (7 other PSD sources and the Project) in a CALPUFF modeling analysis, resulting in the visibility impacts given in Table B-6.

Table B-6 The Project and Cumulative Visibility Impacts from the FLM Modeling Analysis

The Project Visibility Impacts (without other PSD sources)			
Class I Area	Change in Light Extinction (Days > 5%)	Change in Light Extinction (Days > 10%)	Maximum Change in Light Extinction (%)
Yellowstone NP	9	1	12.74 %
UL Bend WA	4	0	8.14 %
North Absaroka WA	5	1	10.47 %
Northern Cheyenne	35	12	38.35%
Visibility Impacts of the Project (with 7 other PSD Sources)			
Class I Area	Change in Light Extinction (Days > 5%)	Change in Light Extinction (Days > 10%)	Maximum Change in Light Extinction (%)
Yellowstone NP	39	24	119.93 %
UL Bend WA	46	28	156.05 %
North Absaroka WA	33	21	126.41 %
Northern Cheyenne	260	224	637.07%

Source: National Park Service and US Fish Wildlife Service, 2002b

Note: CALPUFF modeling with 1990 meteorological data and maximum RH of 98%

Scenario #2 modeling predicted days above 10% extinction with Project emissions alone at YNP and NAW, and numerous days above 10% in the cumulative analysis. This scenario may result in a finding of adverse impact by the FLMs and the resulting impacts to all Class I areas would be rated high.

Scenario #3: Cumulative Visibility Modeling

The proponent provided additional cumulative visibility modeling to address the FLM position that the baseline should be concurrent with the initiation of the PSD program. This modeling used the PSD sources listed in Table B-1, but also included reductions in sulfur dioxide emissions from major sources in the region over the time period of 1975 to present. Table B-7 provides the sources and emissions used in Scenario #3 modeling.

Table B-7 PSD Source SO₂ Emissions Changes Based on 1975 Baseline

Source	1977 ^e Actual Emissions (tpy)	2001 Actual Emissions (tpy)	24-hour Max.		
			Baseline (lb/day)	Current ^f (lb/day)	Change (lb/day)
ExxonMobil Refinery, Billings ^a	9,800	5,112	101,402	53,154	-48,248
YELP, Billings	0	1,932	0	16,320	16,320
Conoco Refinery, Billings ^a	3,198	1,102	71,647	16,901	-54,746
MSCC, Billings ^a	2,000	1,969	198,400	74,336	-124,064
PPL-Corette, Billings ^a	9,986	2,647	78,200	33,296	-44,904
Western Sugar, Billings ^b	815	86	33,070	7,558	-25,512
Cenex Refinery, Laurel ^a	11,830	2,558	76,618	64,957	-11,661
Colstrip 3&4	NA	1,243	0	65,424	65,424
Rocky Mountain Generation	NA	NA	0	4,694	4,694
Anaconda Smelter, Anaconda ^c	321,136	0	1,759,649	0	-1,759,649
Asarco, East Helena ^d	80,000	0	188,420	0	-188,420
Graymont Lime, Townsend	NA	92	0	3,048	3,048
Total	438,765	16,741	2,507,406	336,640	

Source: Bull Mountain Development Company, No. 1, LLC, 2002d

a Baseline 24-hour emissions for Exxon, Conoco, MSCC, PPL and Cenex based on 1989 Pechan Report to EPA, Maximum Feasible Emissions.

b Baseline 24-hour emissions for Western Sugar based on 1989 Pechan Report to EPA, Potential to Emit.

c Baseline 24-hour emissions for Anaconda based on 1977 annual emissions divided by 365 days per year.

d Baseline 24-hour emissions for Asarco based on Operating Permit for facility, representing SIP restrictions.

e 1977 Emission are consistent with 1975 emissions

f Current 24-hour emission for existing and proposed sources based on permit allowables

Scenario #3 CALPUFF visibility modeling was completed by modeling all of the sulfur dioxide emissions increases since the baseline and then modeling all of the emissions decreases since the baseline. The shut-down of the Anaconda Smelter and the ASARCO Lead Smelter in East Helena, along with reductions in sources of sulfur dioxide in the Billings-Laurel area since adoption of a new State Implementation Plan (SIP) have produced large reductions of sulfur dioxide in the region. By modeling both increases and decreases and aggregating results in post-processing of the model data, a more complete picture of emissions changes and resulting visibility impairment is presented. Tables B-8, B-9, and B-10 provide the results of cumulative visibility monitoring under this Scenario for YNP, UL Bend and NAW.

Table B-8 Scenario #3: Yellowstone National Park Cumulative Visibility Modeling

Date	Receptor Number	RHDS ^a b _{ext} % (%)	RHIS ^b b _{ext} % (%)	Cumulative b _{ext} % (%)	Receptor Number	Project b _{ext} % (%)
March 5	33	120.03	-104.29	15.74	234	12.86
September 19	170	45.01	-292.09	-247.08	--	<5%
May 12	33	43.02	-237.42	-194.40	--	<5%
September 28	61	40.07	-43.23	-3.16	183	7.14
February 14	58	38.46	-129.39	-90.93	--	<5%
May 11	57	35.03	-102.07	-67.04	--	<5%
February 13	59	33.09	-73.92	-40.83	--	<5%
June 15	33	32.35	-52.01	-19.66	--	<5%
July 20	246	30.12	-173.20	-143.08	214	9.63
August 3	58	26.76	-14.99	11.77	--	<5%
July 21	58	26.14	-10.62	15.52	--	<5%
August 11	33	24.56	-127.11	-102.55	--	<5%
January 15	33	22.73	-350.89	-328.16	33	8.22
June 16	33	21.23	-46.76	-25.53	--	<5%
January 16	33	20.61	-639.65	-619.04	33	5.66
September 20	157	20.43	-221.89	-201.46	--	<5%
September 18	33	20.01	-111.73	-91.72	--	<5%
July 22	58	19.68	-49.60	-29.92	--	<5%
December 21	113	14.97	-1.83	13.14	--	<5%
August 10	33	13.30	-78.07	-64.77	--	<5%
March 6	113	12.44	-6.99	5.45	--	<5%
March 23	214	12.38	-65.63	-53.25	214	5.81
July 10	33	12.06	-164.32	-152.26	--	<5%
August 4	33	11.20	-96.43	-85.23	--	<5%
July 19	40	10.04	-244.98	-234.94	34	5.59

Source Bull Mountain Development Company, No. 1, LLC., 2002d

^aRegional Haze Deteriorating Sources (RHDS); emissions from sources commencing after guideline baseline date of January 6, 1975

^bRegional Haze Improving Sources (RHIS); emissions from sources shutting down after guideline baseline date of January 6, 1975

Note: Relative Humidity (RH) Factor Estimation Method: Hourly CALMET Database RH Data (Maximum RH of 98% for Particle Growth)

Table B-9 Scenario #3: UL Bend Wilderness Area Cumulative Visibility Modeling

Date	Receptor Number	RHDS (1) b _{ext} [%] (%)	RHIS (2) b _{ext} [%] (%)	Cumulative b _{ext} [%] (%)	Receptor Number	Project b _{ext} [%] (%)
February 16	243	143.49	-139.45	4.04	243	8.01
November 25	243	131.58	-13.92	117.66	--	<5%
March 7	243	87.62	-8.22	79.40	--	<5%
February 17	243	83.35	-132.55	-49.20	243	6.88
August 26	243	57.02	-277.34	-220.32	243	8.53
September 2	243	28.01	-41.82	-13.81	--	<5%
May 12	243	25.92	-5.47	20.45	--	<5%
May 14	243	25.53	-14.83	10.70	--	<5%
February 1	243	24.29	-123.00	-98.71	--	<5%
September 16	243	22.78	-11.95	10.83	--	<5%
February 15	243	22.75	-55.82	-33.07	243	6.49
May 15	243	20.98	-30.04	-9.06	--	<5%
September 5	243	20.95	-44.36	-23.41	--	<5%
June 16	243	20.35	-12.43	7.92	--	<5%
September 19	243	17.52	-15.10	2.42	--	<5%
September 29	243	17.24	-14.00	3.24	--	<5%
August 27	243	14.00	-477.44	-463.44	--	<5%
May 27	243	13.93	-38.77	-24.84	--	<5%
May 23	243	12.90	-13.16	-0.26	--	<5%
July 31	243	11.73	-74.30	-62.57	--	<5%
July 23	243	11.64	-29.03	-17.39	--	<5%
December 10	243	11.22	-56.13	-44.91	--	<5%
July 25	243	10.55	-13.64	-3.09	--	<5%

Source: Bull Mountain Development Company, No. 1, LLC., 2002d

Table B-10 Scenario #3: North Absaroka Wilderness Area Cumulative Visibility Modeling

Date	Receptor Number	RHDS _a b _{ext} [%] (%)	RHIS _b b _{ext} [%] (%)	Cumulative b _{ext} [%] (%)	Receptor Number	Project b _{ext} [%] (%)
March 5	349	124.89	-106.38	18.51	349	7.25
May 12	349	46.41	-237.96	-191.55	--	<5%

Date	Receptor Number	RHDS ^a bext% (%)	RHIS ^b bext% (%)	Cumulative bext% (%)	Receptor Number	Project bext% (%)
June 15	349	43.03	-73.52	-30.49	--	<5%
February 14	350	40.43	-127.60	-87.17	--	<5%
January 15	349	32.36	-360.22	-327.86	349	11.07
May 11	350	32.03	-88.39	-56.36	--	<5%
September 28	350	30.34	-19.38	10.96	350	5.30
January 16	349	28.97	-663.84	-634.87	349	7.68
February 13	350	28.85	-57.37	-28.52	--	<5%
June 16	349	28.27	-66.18	-37.91	--	<5%
August 11	350	27.56	-133.87	-106.31	--	<5%
July 20	350	25.81	-73.18	-47.37	--	<5%
September 19	349	23.20	-136.56	-113.36	--	<5%
September 18	349	21.74	-112.57	-90.83	--	<5%
August 5	350	21.20	-7.33	13.87	--	<5%
July 22	350	16.54	-40.76	-24.22	--	<5%
July 21	350	16.23	-12.97	3.26	--	<5%
August 10	349	15.13	-88.78	-73.65	--	<5%
July 10	349	13.75	-162.97	-149.22	--	<5%
August 4	349	11.87	-99.45	-87.58	--	<5%
July 19	350	10.42	-228.03	-217.61	350	6.15

Source: Bull Mountain Development Company, No. 1, LLC, 2002^d

^aRegional Haze Deteriorating Sources (RHDS); emissions from sources commencing after guideline baseline date of January 6, 1975

^bRegional Haze Improving Sources (RHIS); emissions from sources shutting down after guideline baseline date of January 6, 1975

Note: Relative Humidity (RH) Factor Estimation Method: Hourly CALMET Database RH Data (Maximum RH of 98% for Particle Growth)

Results of cumulative visibility modeling in Scenario #3 show improvement over the more conservative results from Scenario #2. However, Tables B-8 and B-10 still show impacts exceeding the 10% light extinction level, for both cumulative analyses and the Project alone. These results indicate a potential for an impact to visibility in Class I areas that rates high. Table B-9 shows impacts at UL Bend that exceed 10% in the cumulative mode, but no exceedances of the 10% criteria by the Project alone. Impacts due to the Project at UL Bend would be considered moderate.

Since the cumulative model-predicted impacts remain above 10% at YNP and NAW in all three scenarios and the Project impacts are above the visibility *de minimis* level (0.4%), the FLM and MDEQ will need to make a decision as to whether or not the Project adversely affects the Class I areas.

The proponent has further analyzed the modeled visibility results on a case-by-case basis for the highest impact days and has asserted in a letter to MDEQ that, on the days the model-predicted impacts exceed the 10% threshold, the Project does not adversely impact visibility in any of the Class I areas. (Bull Mountain Development Company No 1 LLC, 2002c). In this letter, the proponent explains that during the high impact days, CALPOST, when predicting a change in light extinction, is highly sensitive to relative humidity. The model-predicted change in light extinction is calculated relative to natural background conditions. The proponent claims that on most model-predicted high impact days, weather conditions (e.g., snow, fog, rain, etc.) are causing changes in light extinction greater than any model-predicted visibility impact from the Project. Therefore, the proponent claims that the Project's visibility impacts on days of high relative humidity are insignificant compared to visibility impairment caused by natural conditions (snow, fog, rain, etc.). When the high relative humidity days are excluded, the predicted visibility impacts to the Class I areas are all below the 5% change in light extinction threshold. If the proponent's assertions about the CALPUFF model are accepted by DEQ and/or the FLMs, no cumulative visibility analysis would be expected at any of the Class I areas

INDEX

- Acid Rain**, 1, 5
- ACSR**, 22, 1
- Air Pollution**, 3, 1
- Air Quality**, 1, 6, 7, 8, 38, 3, 8, 9, 1, 4, 5, 6, 14, 25, 1, 3, 1, 2, 3, 2, 1, 9, 5, 6, 7, 8, 33, 6
- Air Resources**, 1, 36, 2, 3, 24, 56, 99, 1
- Alluvial**, 1
- Alluvium**, 1
- Ambient Air Quality**, 7, 8, 9, 2, 4, 20, 1, 2, 1, 6, 3
- ANSI**, 2, 1
- Anticline**, 1
- Apiary**, 1
- AQRV**, 4, 6, 16, 1
- Aquifer**, 27, 29, 104, 2
- Artesian flow**, 14, 2
- ASME**, 2, 1
- Best Available Control Technology (BACT)**, 8, 2, 6
- Best Management Practices (BMP)**, 2
- Big Game**, 2
- Bituminous**, 12, 2, 14
- BPA**, 51, 73, 98, 108, 2
- BTU**, 2
- CAA**, 2, 16, 2
- CAAA**, 2, 11, 2
- Cairn**, 2
- Carbonic Acid/Carbon Dioxide**, 2
- CCD**, 61, 62, 64, 73, 88, 2
- CFC**, 2
- CFR**, 6, 20, 34, 3, 1, 2, 8, 4, 5, 7, 8, 4, 5, 11, 21
- Chemical Cleaning**, 3
- Circulating Fluidized Bed Combustion (CFBC)**, 3
- Clean Air Act**, 1
- Clinker**, 3
- CO**, 3, 4, 11, 12, 13, 4, 6, 7, 9, 10, 11, 12, 14, 15, 16, 19, 22, 24, 40, 100, 2, 3, 5, 21, 9, 19, 20, 27, 28, 30, 31, 32, 33
- Coal Seam**, 3
- Conservation Reserve Program**, 57, 9, 3
- Conveyor**, 9, 20, 3
- CRIS**, 36, 2
- Cultural Resources**, 40, 33, 35, 43, 51, 56, 105, 2, 4, 6, 3
- Decibel (dB)**, 3
- DEIS**, 28, 32, 1, 2, 3
- DEQ**, 1, 6, 7, 8, 9, 1, 2, 38, 46, 52, 55, 13, 28, 32, 35, 1, 2, 3, 5, 6, 10, 11, 17, 18, 19, 25, 31, 35, 36, 40, 103, 1, 2, 3, 1, 2, 3, 7, 3, 4, 5, 6, 8, 14
- Dip**, 3
- Earth Resources**, 39, 15, 32, 4
- EC**, 20, 3
- Electrostatic Precipitator (ESP)**, 4
- Emission**, 11, 10, 6, 7, 8, 10, 14, 23, 42, 99, 3, 4, 6, 1, 13, 17, 21, 3, 4, 5, 6, 23, 27, 28, 29, 30, 31, 32, 33
- Emission Standard**, 3, 5
- EPA**, 15, 44, 46, 4, 10, 13, 46, 2, 3, 4, 6, 11, 12, 13, 16, 19, 20, 21, 22, 23, 35, 64, 66, 67, 68, 69, 70, 74, 102, 106, 3, 4, 5, 9, 2, 3, 8, 23, 3, 10

- Ephemeral Drainage**, 4
- FD**, 66, 74, 4
- FEIS**, 13, 23, 28, 32, 45, 50, 53, 26, 32, 38, 46, 49, 51, 64, 74, 105, 4
- FGR**, 47, 9, 4, 10
- Flue Gas Desulfurization (FGD)**, 4, 1
- Fluidized Bed Combustion**, 4
- Fluvial**, 4
- Fly Ash**, 17, 4, 27
- Formation**, 13, 14, 16, 21, 29, 30, 4
- Fossil Fuels**, 4
- Fugitive Dust**, 4, 23
- Glaciated**, 4
- Greenhouse Effect**, 4
- Groundwater**, 39, 42, 14, 15, 30, 32, 36, 37, 2, 5
- Group**, 13, 14, 16, 17, 3, 4, 5
- GVW**, 74, 4
- GWP**, 3, 22, 4
- HAP**, 46, 10, 2, 6, 7, 8, 11, 12, 25, 5, 8, 28, 30, 31, 32, 33
- HCFC**, 5
- HFC**, 5
- High Sulfur**, 5
- Historic**, 7, 33, 34, 2, 3, 7, 5, 6, 8
- Hydrostratigraphy**, 5
- ID**, 66, 74, 5, 21
- Infrastructure**, 8, 9, 97, 98, 107
- Intermittent Stream**, 5
- IPCC**, 3, 22, 2, 5
- ISC**, 99, 101, 5
- ISO**, 63, 64, 8, 5
- Lacustrine**, 5
- L_{dn}**, 41, 46, 49, 50, 64, 66, 67, 68, 69, 70, 74, 106, 5
- Lithic**, 5, 6
- Lithic Scatter**, 6
- LNB**, 9, 10, 6, 9
- Longwall Mining**, 6
- MAAQS**, 2, 3, 4, 13, 15, 16, 24, 99, 100, 101, 6
- MACT**, 2, 11, 12, 6, 8
- MDEQ**, 6, 4, 13, 14
- MDFWP**, 104, 6
- MDSL**, 19, 20, 28, 29, 32, 98, 1, 6
- MEPA**, 1, 6, 8, 1, 16, 97, 1, 2, 3, 6
- Montana Environmental Policy Act, 1
- MPDES**, 16, 29, 35, 36, 37, 6
- NAAQS**, 2, 3, 4, 13, 15, 16, 24, 99, 100, 101, 6
- National Acid Precipitation Assessment Program (NAPAP)**, 6
- National Register of Historic Places**, 7, 34, 6
- NET**, 10, 6
- NFPA**, 2, 20, 6
- Nitrogen Dioxide (NO₂)**, 6
- Nitrogen Oxides (NO_x)**, 7
- NMVOC**, 22, 6
- Noise**, 9, 38, 41, 45, 46, 47, 49, 50, 52, 63, 64, 65, 66, 67, 68, 69, 71, 75, 106, 3, 4, 7, 8, 9
- Noxious Weeds**, 41, 7
- NRHP**, 6
- NSPS**, 6, 4, 8, 11
- NTI**, 10, 6
- NWS**, 13, 6

- OSHA**, 2, 45, 7
- PA**, 66, 74, 7, 15
- Permeability**, 7
- Petroglyph**, 7
- PFC**, 7
- PM**, 40, 49, 57, 7, 12, 98, 102
- PM₁₀**, 46, 47, 3, 7, 9, 11, 12, 13, 4, 6, 7, 10, 11, 12, 14, 15, 16, 18, 24, 25, 100, 101, 7, 2, 5, 3, 8, 9, 11, 12, 13, 19, 20, 27, 29, 30, 31, 33, 3, 4
- Porosity**, 7
- Post-Combustion Cleaning**, 7
- Pre-Combustion Cleaning**, 7
- Prehistoric**, 33, 6, 7
- Preparation Plant**, 4
- PSD**, 9, 36, 2, 3, 4, 6, 9, 12, 13, 15, 16, 18, 24, 56, 99, 100, 101, 102, 103, 1, 2, 7, 21, 33, 1, 3, 4, 6, 7, 9, 10
- RAS**, 107, 7
- Reclamation**, 1, 7
- Right-of-Way (ROW)**, 7
- RO**, 14, 27
- Rockshelter**, 54, 8
- SCR**, 11, 12, 27, 31, 47, 9, 10, 26, 8, 2, 1, 11
- Scrubber**, 3, 8, 9, 15, 17
- Section 106**, 7, 40, 34, 105, 106, 3, 8
- Slurry**, 8
- SNCR**, 47, 9, 8, 10
- SO₂**, 12, 44, 47, 2, 3, 4, 8, 9, 11, 12, 13, 4, 6, 7, 9, 10, 11, 12, 14, 15, 16, 18, 19, 24, 40, 99, 100, 101, 102, 3, 8, 9, 2, 3, 5, 6, 7, 13, 14, 15, 21, 8, 9, 13, 14, 15, 16, 17, 18, 19, 22, 27, 33, 34, 3, 4, 5, 6, 10
- Socioeconomic Effects**, 8
- Sorbent**, 17, 27, 29
- Special Status Species**, 8
- State Historic Preservation Officer (SHPO)**, 34, 8
- Stratigraphy**, 18
- Sulfur Dioxide Emission / Sulfuric Acid-Sulfate**, 8
- Syncline**, 8
- Tertiary**, 14, 15, 9
- Topsoil**, 4, 19, 36, 9
- Traditional Cultural Property (TCP)**, 54, 9
- TSP**, 9
- USEPA**, 9
- USGS**, 13, 15, 23, 28, 32, 13, 40, 9
- UTM**, 1, 13, 9
- Viewshed**, 54, 57, 9
- Visual Resources**, 40, 36, 45, 56, 62, 106, 1, 7, 9
- Visual Resources Management System (VRM)**, 9
- Volatile Organic Compound (VOC)**, 9, 2
- Waste**, 17, 39, 45, 49, 74, 12, 35, 37, 61, 69, 92, 2, 10
- Water Resources**, 9, 39, 13, 26, 32, 104, 3
- Wetlands**, 39, 27, 45, 2, 9
- Wildlife Resources**, 39, 28, 45, 49, 104, 5
- WRCC**, 2, 9
- YNP**, 9, 16, 17, 18, 102, 103, 9, 3, 4, 6, 9, 10, 13

State Location

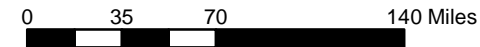
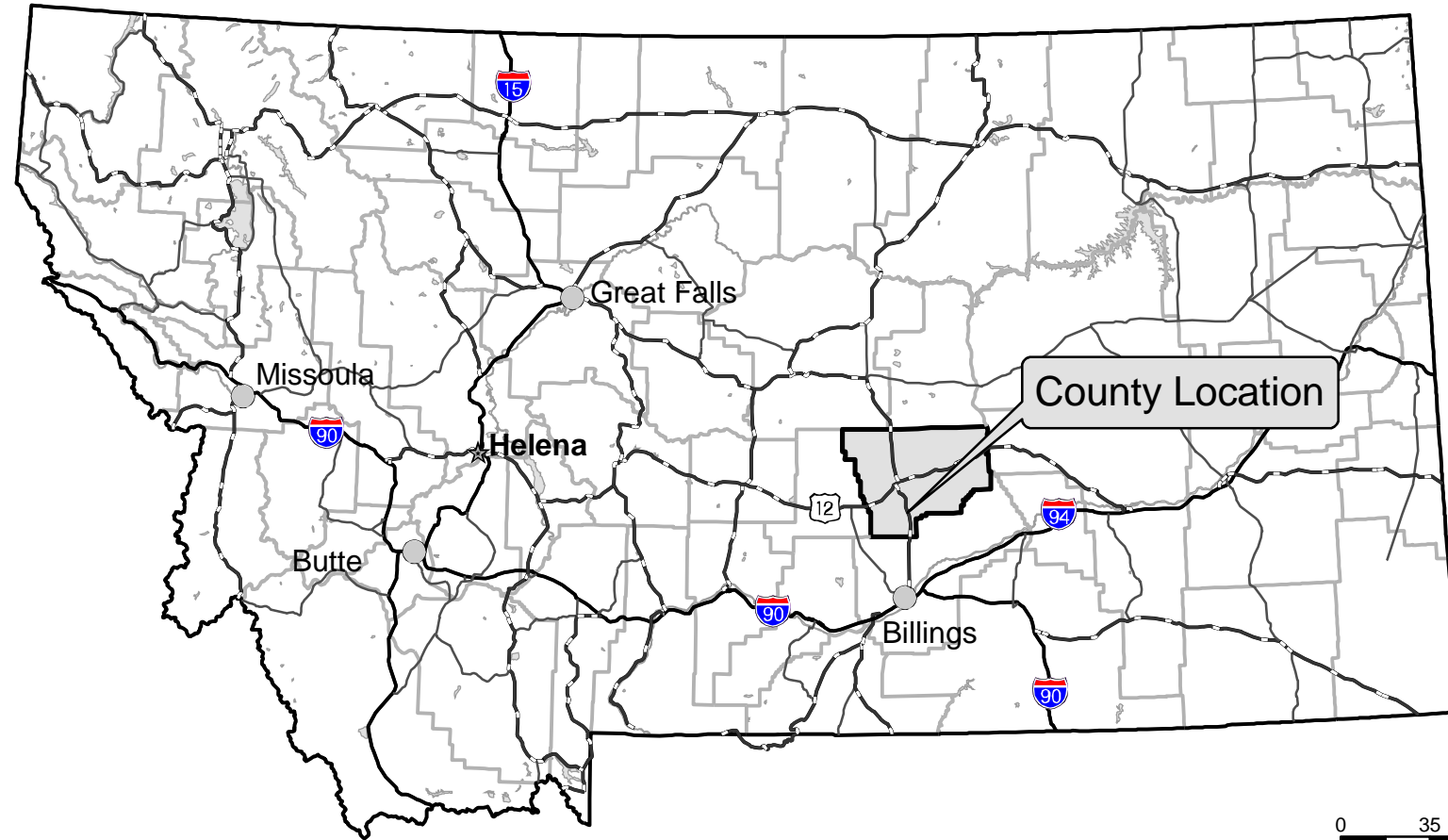

Figure 1-1

Vicinity Map

Roundup Power Project DEIS

Legend

- Preliminary Transfer Location
- Towns
- Cities
- State Capital
- Conveyor Location
- Proposed Transmission
- Interstate Highway
- U.S. Highway
- State Highway
- County Road
- Proposed Railroad
- County Line
- Lake / Stream

County Location

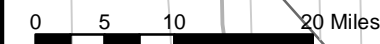
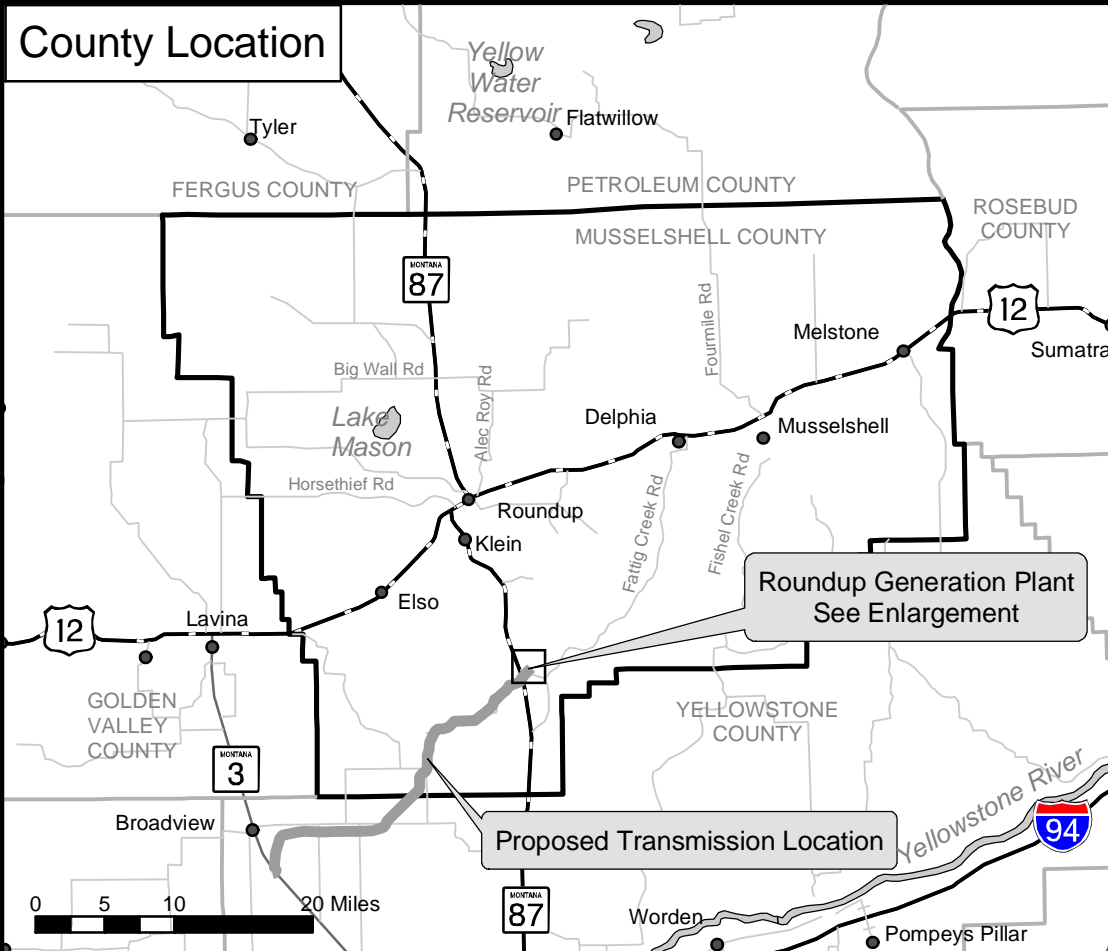

Roundup Power Project Location (Enlargement)

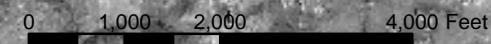
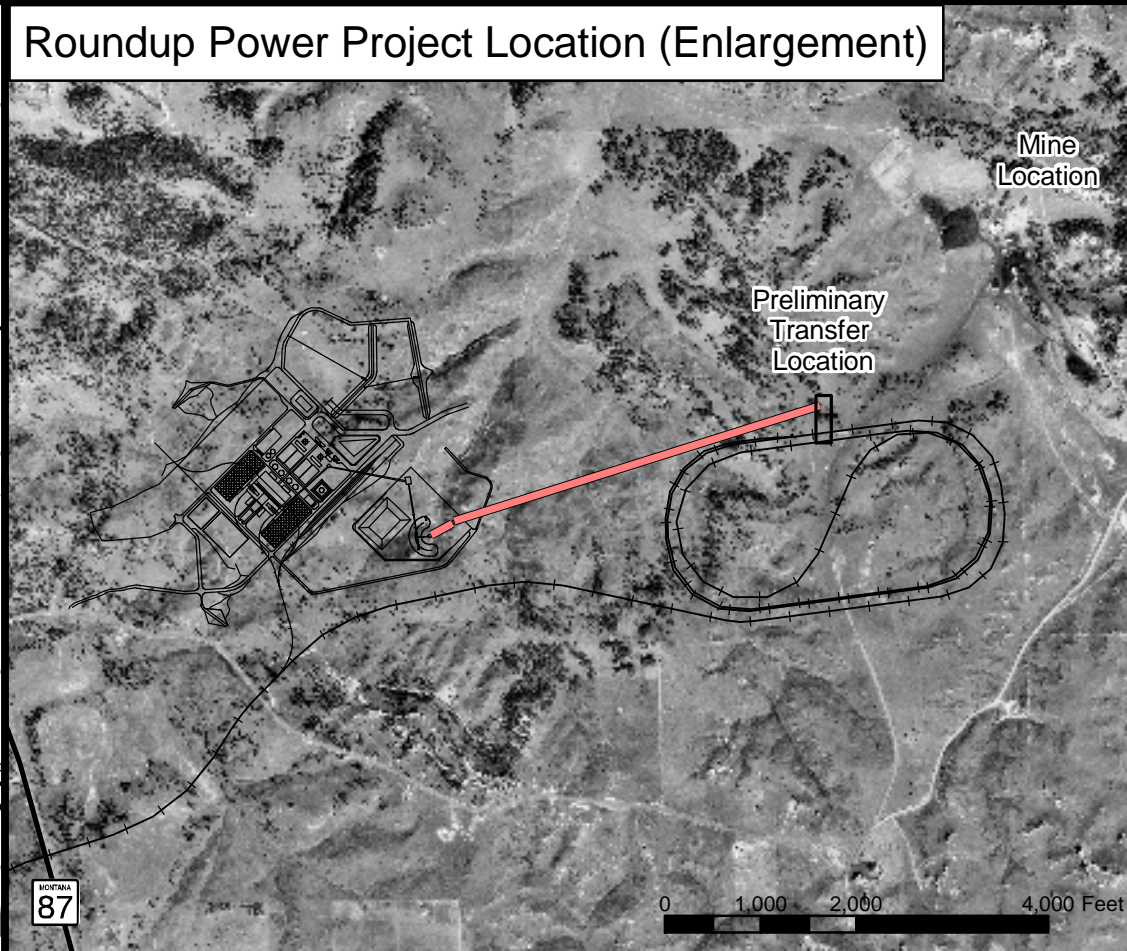

T06NR26E



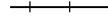



Figure 2-10

Alternative Solid Waste Disposal Area

Roundup Power Project DEIS

Legend

-  Preliminary Transfer Location
-  Fence Line
-  State Highway
-  Proposed Railroad
-  Section Line
-  River / Stream

1" : 1,250'

0 625 1,250 2,500 Feet













Figure 2-11

Transmission System

Roundup Power Project DEIS

Legend

-  Residential
-  Proposed Transmission Line
-  Milepost
-  Substation
-  State Highway
-  Local Road
-  Proposed Railroad
-  County Line
-  Township/Range
-  River

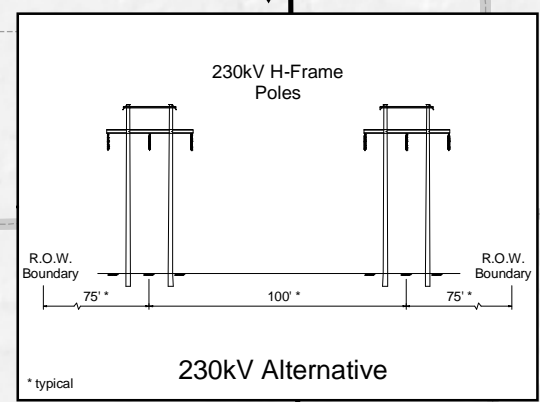
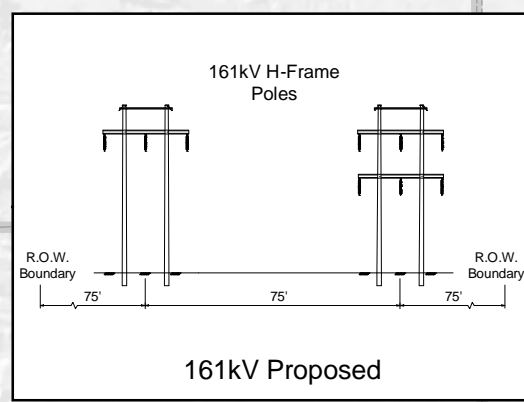
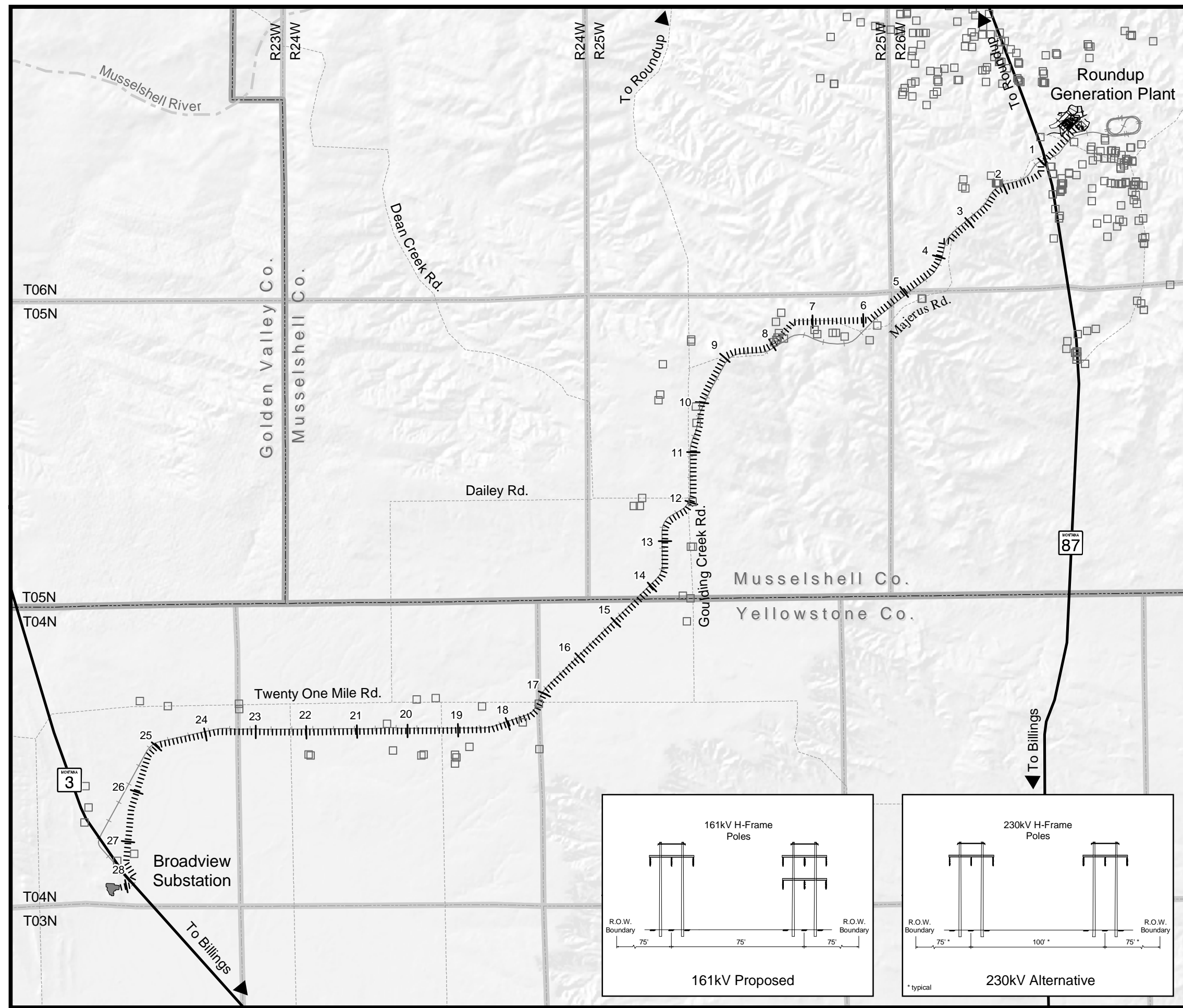

Scale 1 : 125,000

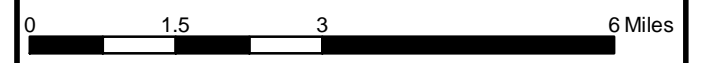
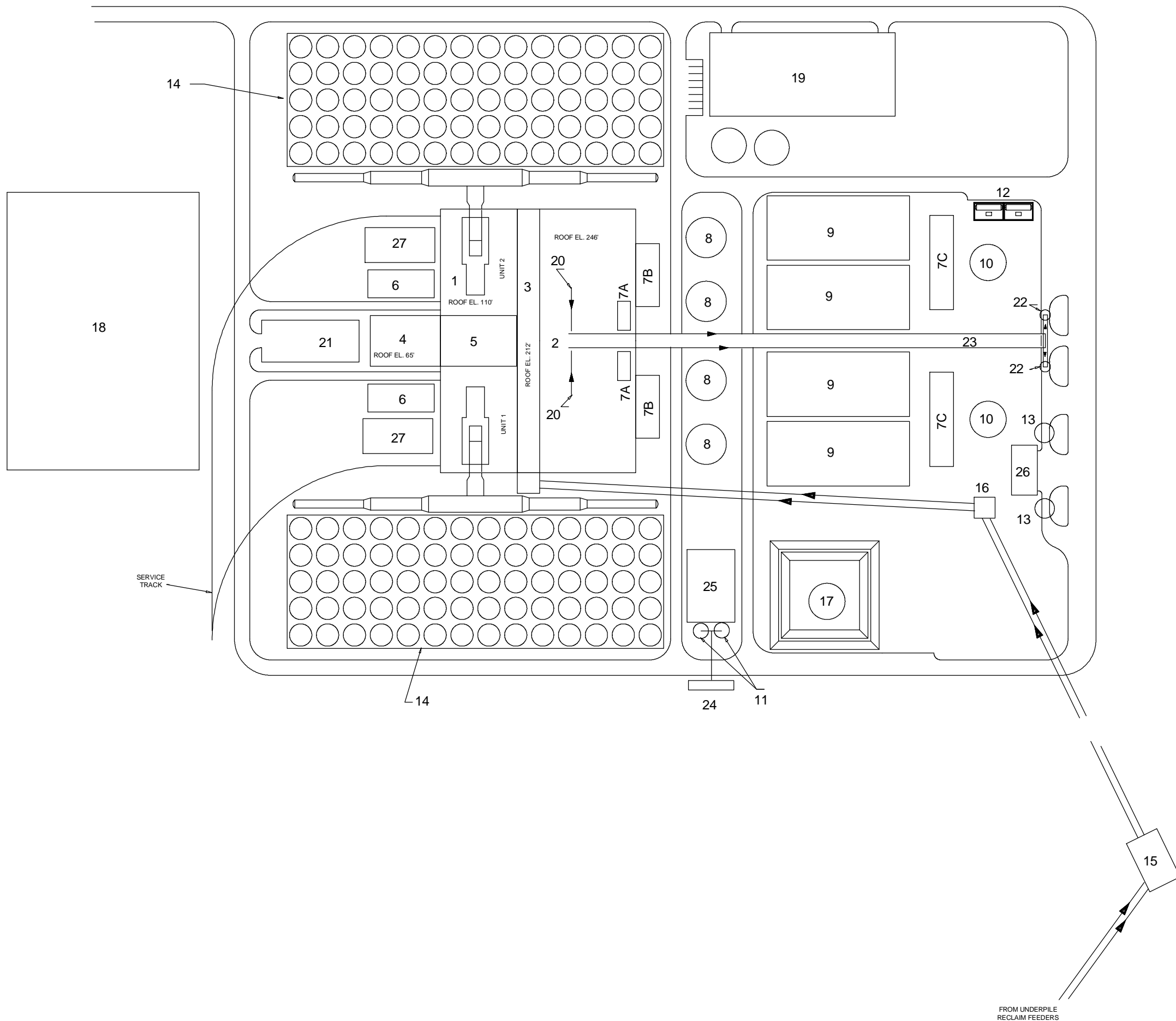
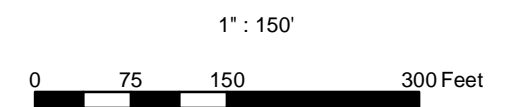

Figure 2-2

Plant Layout

Roundup Power Project DEIS

Legend	
1	Turbine Room
2	Boiler Room
3	Pulverizer/Silo Bay
4	Administration
5	Control Room & Electrical Equip.
6	Transformers
7	Fans (A=P.A. B=F.D. C=I.D.)
8	Dry FGD Absorbers
9	Baghouses
10	Chimneys
11	Lime Storage Silos
12	Ammonia Tanks for SCR
13	Ash Silos
14	Air Cooled Condenser
15	Coal Crusher House
16	Transfer Tower
17	Oil Tank
18	Switchyard
19	Water Treatment, Shops/Storage
20	Drag Chain Conveyors
21	Parking
22	Bottom Ash Silos
23	Bottom Ash Conveyors
24	Lime Unloading Facility
25	Lime Preparation Building
26	Flyash Blower Building
27	Water to Air Cooler



FROM UNDERPILE RECLAIM FEEDERS

T06NR26E









Figure 2-3

Site Design

Roundup Power Project DEIS

Legend

-  Preliminary Transfer Location
-  Fence Line
-  State Highway
-  Proposed Railroad
-  Section Line
-  River / Stream

1" : 1,250'

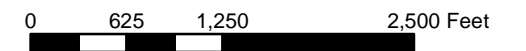

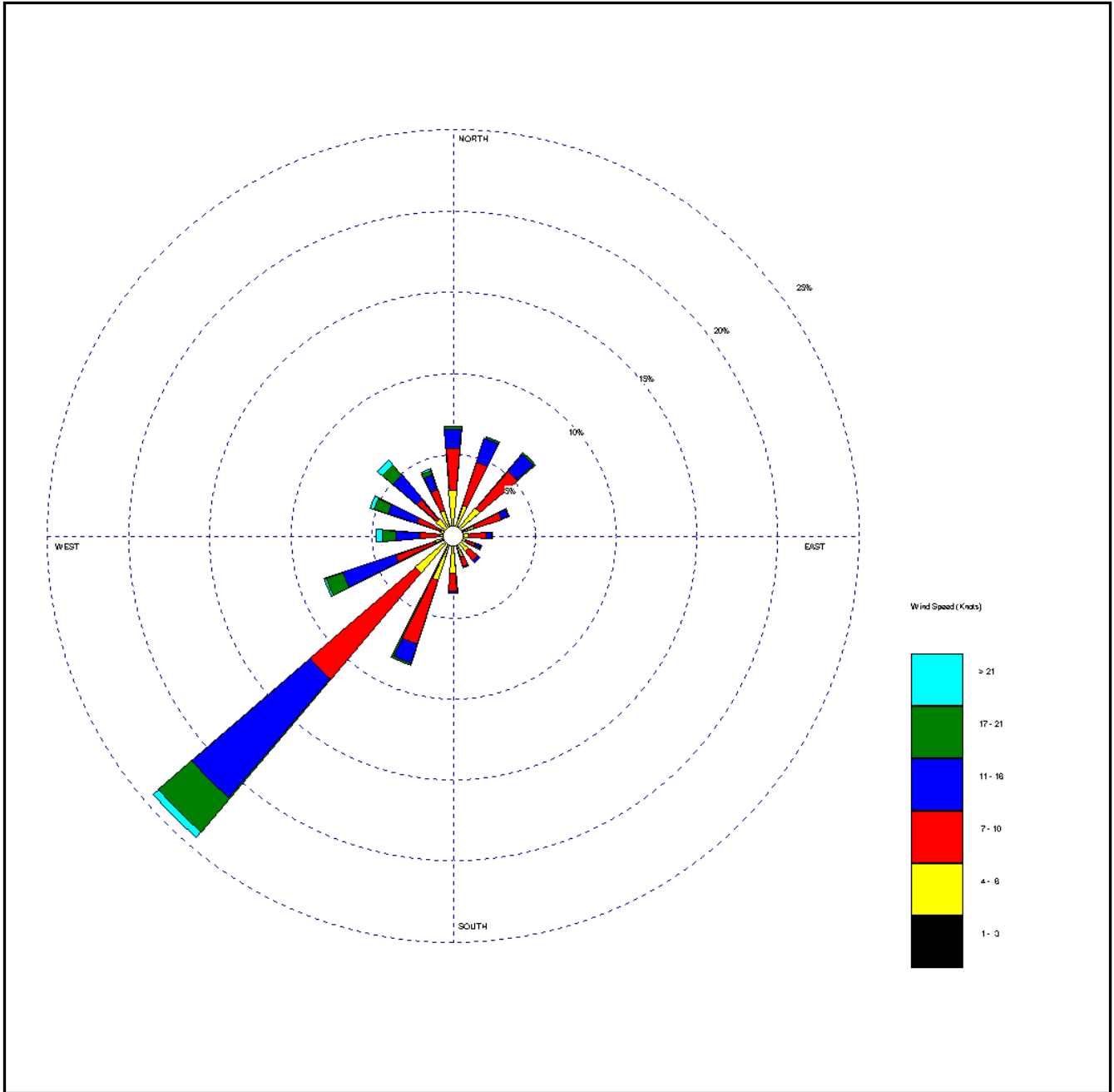

Figure 3-1 Billings WSO, Montana, Wind Rose, 1986-1990

T06NR26E

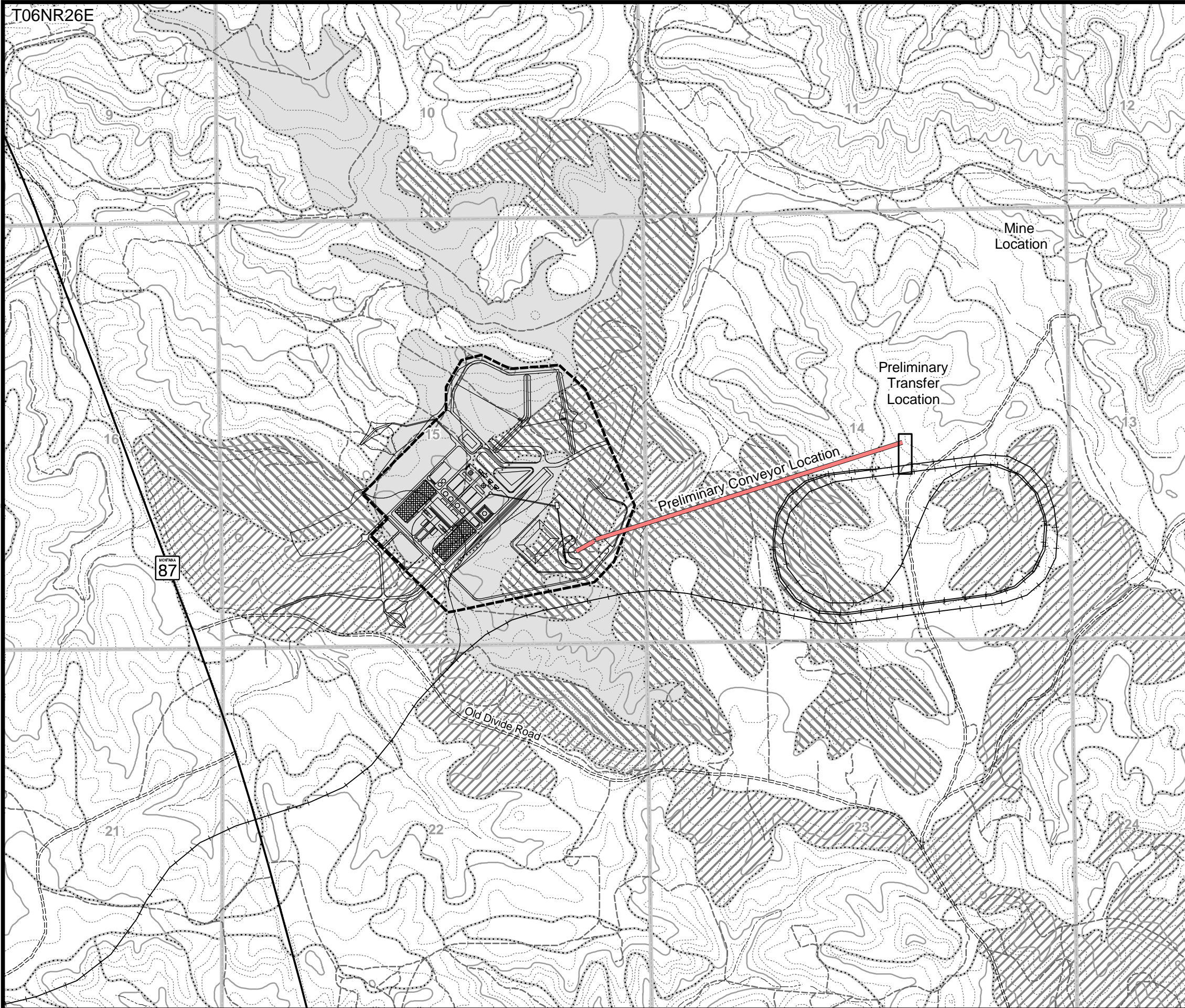



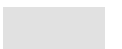





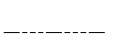



Figure 3-3

Soils

Roundup Power Project DEIS

Legend

-  Soil Boundary
-  B - Cabba-Barvon Loams, 15-65% Slope
-  C - Cabba-Doney Loams, 8-45% Slope
-  D - Doney-Cabba-Macar Loams, 4-15% Slope
-  Preliminary Transfer Location
-  Fence Line
-  State Highway
-  Local Road
-  Dirt Road
-  Proposed Railroad
-  Section Line
-  River / Stream

1" : 1,250'

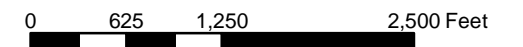

T06NR26E

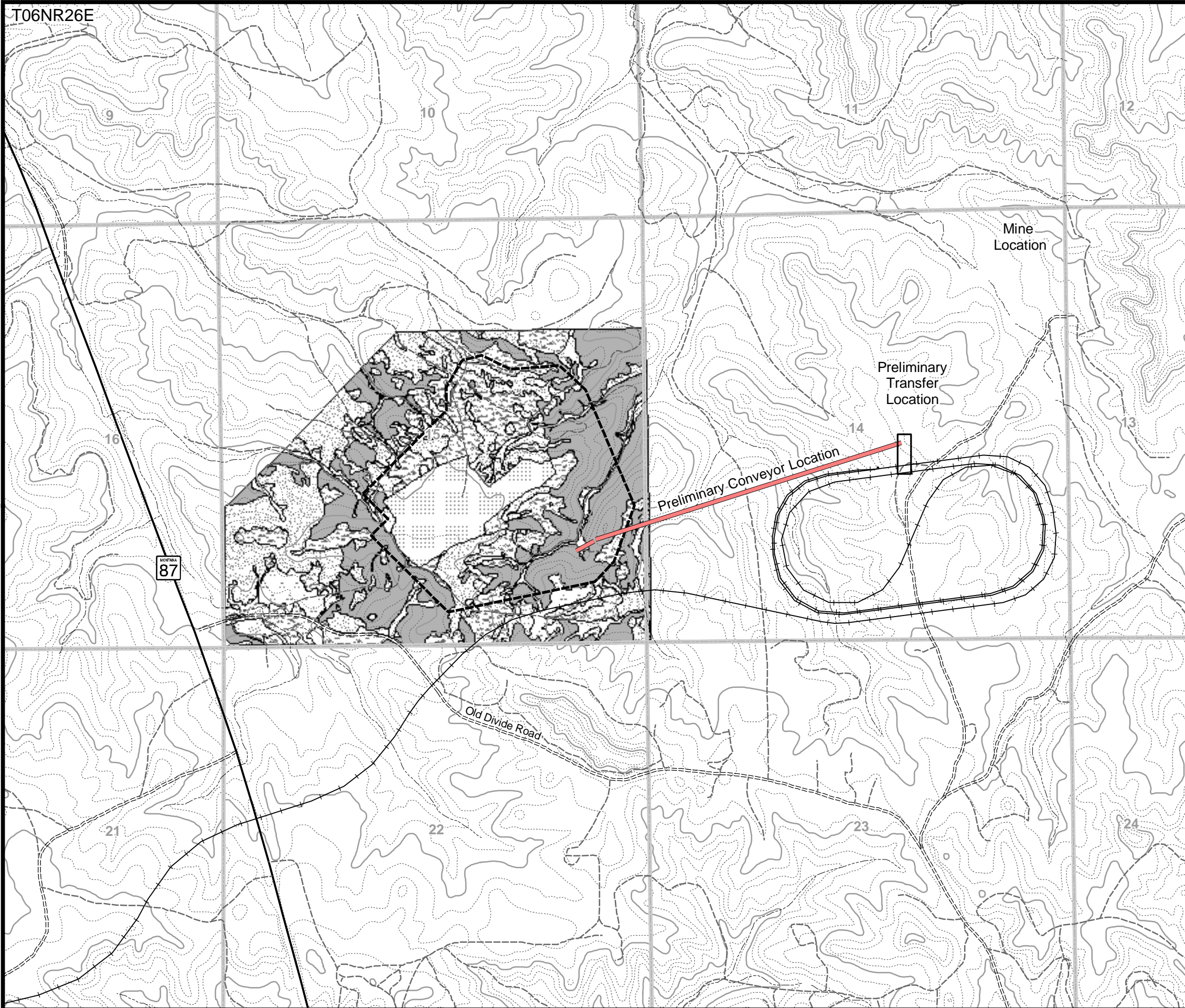















Figure 3-4

Vegetation

Roundup Power Project DEIS

Legend

-  Agricultural Land
-  Burned Ponderosa Pine Stands
-  Grassland
-  Ponderosa Pine Savannah & Forest
-  Shrub/Grassland
-  Preliminary Transfer Location
-  Fence Line
-  State Highway
-  Local Road
-  Dirt Road
-  Proposed Railroad
-  Section Line
-  River / Stream

1" : 1,250'

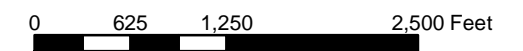

Figure 3-5

Sensitive Views

Roundup Power Project DEIS

Legend

- Sensitive View Points
- 0-0.5 Foreground Distance Zone
- 0.5-1.0 Middle Ground Distance Zone
- 1.0-5.0 Background Distance Zone
- Preliminary Transfer Location
- Fence Line
- State Highway
- Local Road
- Dirt Road
- Proposed Railroad
- Township / Range
- Section Line
- River / Stream

1" : 2,200'

0 1,250 2,500 5,000 Feet

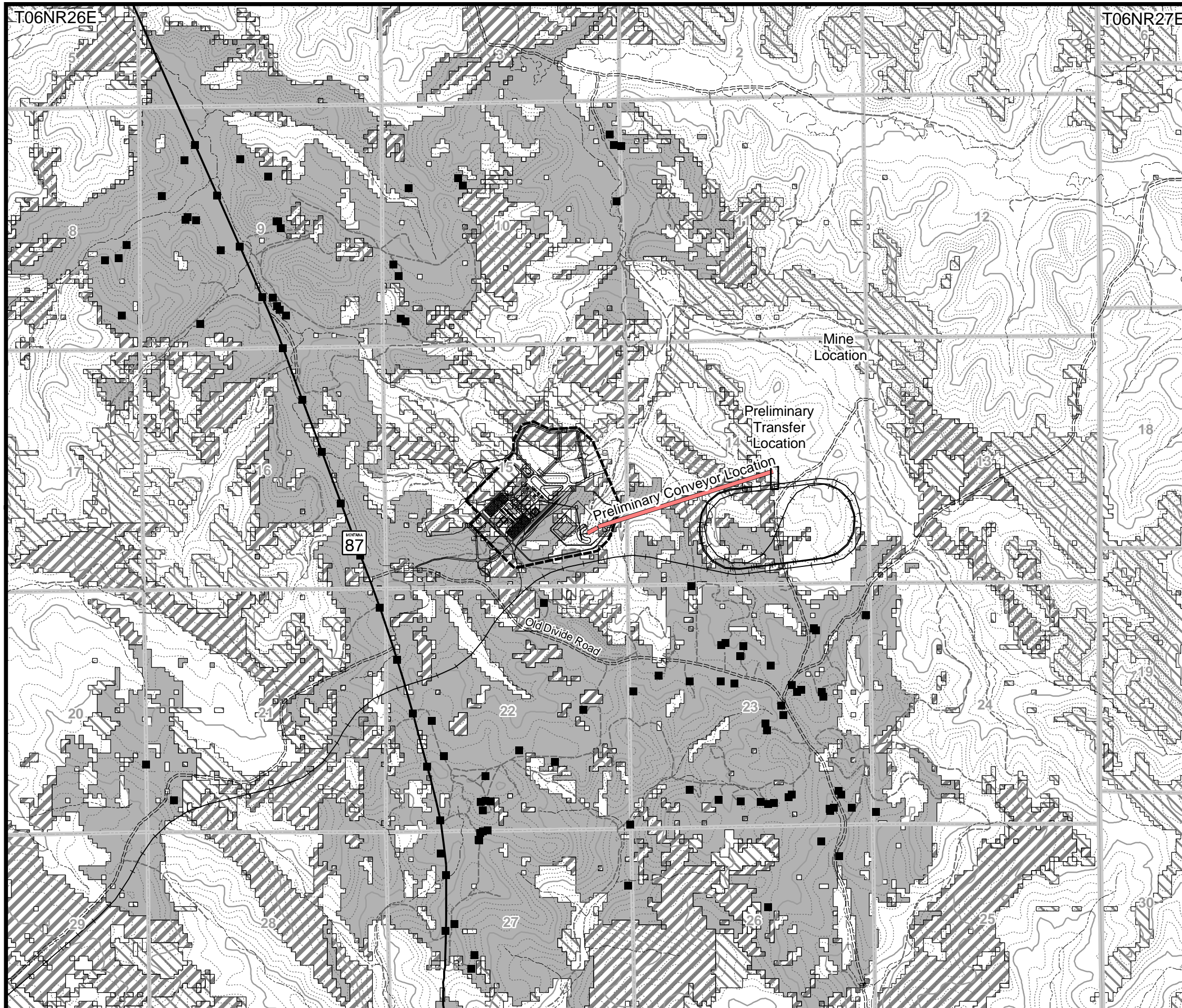

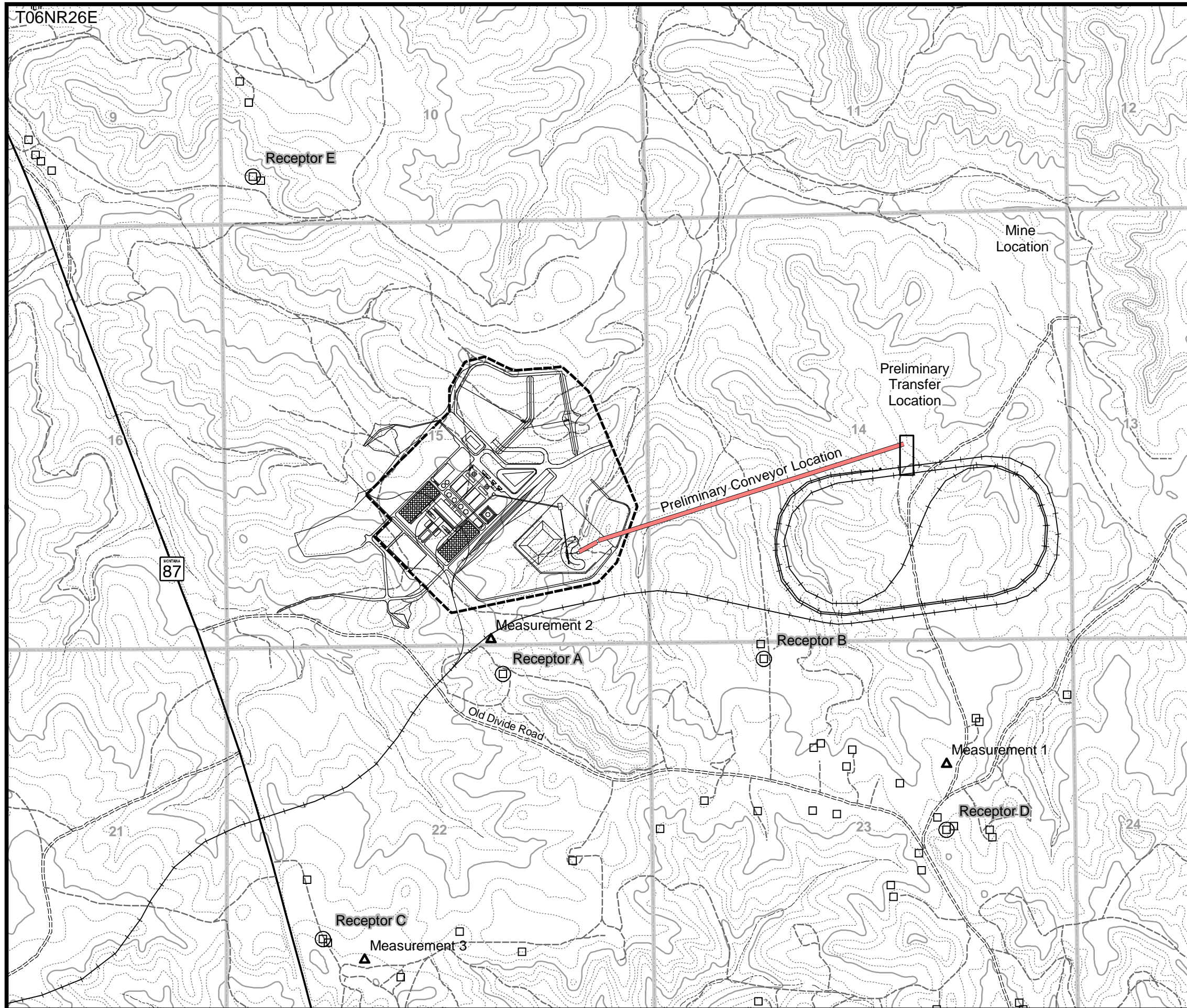

Figure 3-6

Noise

Roundup Power Project DEIS

Legend

- ▲ Noise Measurement Location
- ⊙ Noise Receptor Location
- Residence
- ▭ Preliminary Transfer Location
- Fence Line
- State Highway
- ===== Local Road
- - - - - Dirt Road
- +—+— Proposed Railroad
- Section Line
- - - - - River / Stream

1" : 1,250'

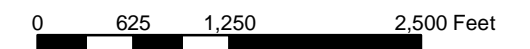

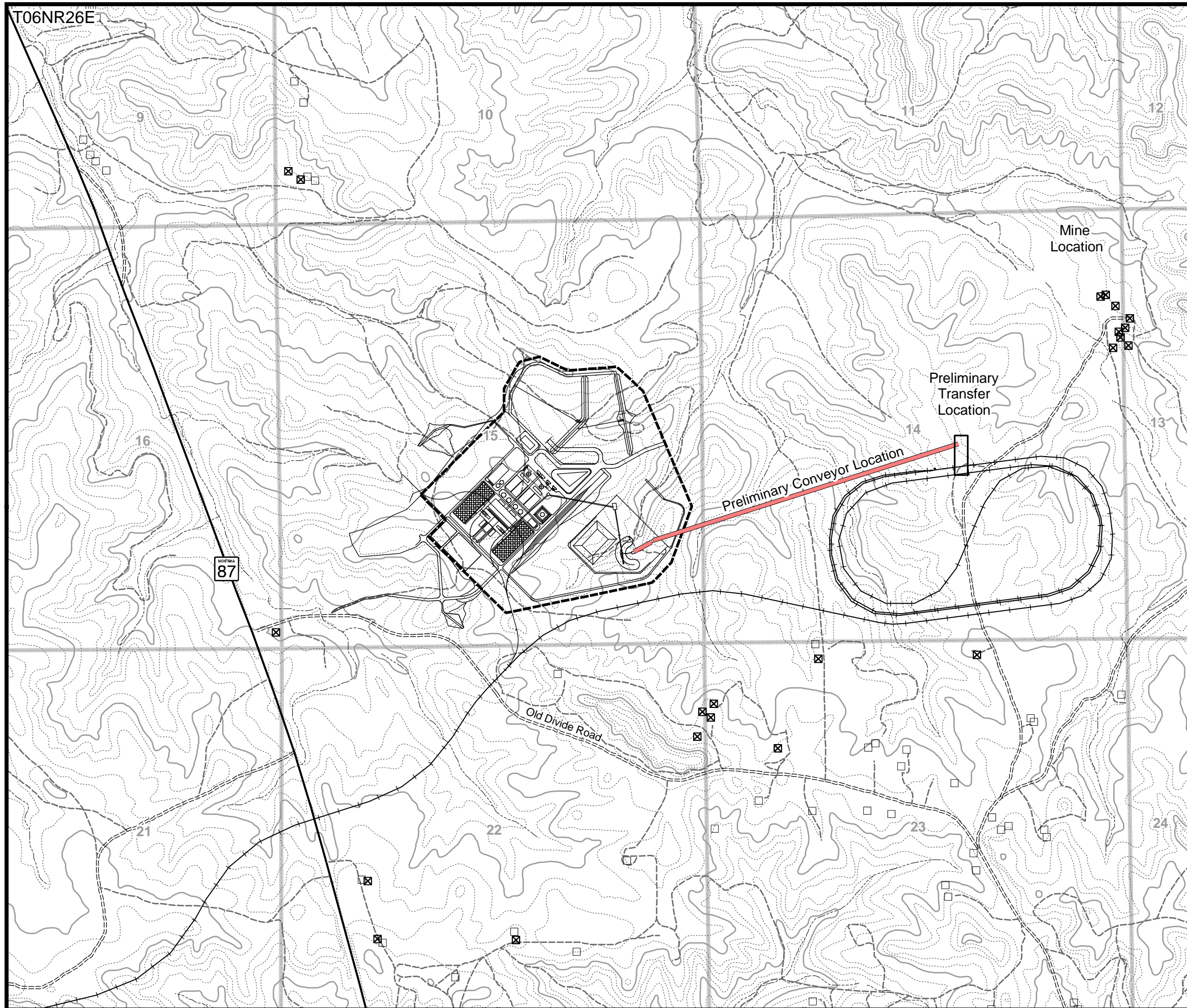











Figure 3-7

Land Use

Roundup Power Project DEIS

Legend

-  Residence
-  Non-Residential Structure
-  Preliminary Transfer Location
-  Fence Line
-  Proposed Railroad
-  State Highway
-  Local Road
-  Dirt Road
-  Section Line
-  River / Stream

1" : 1,250'

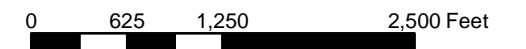

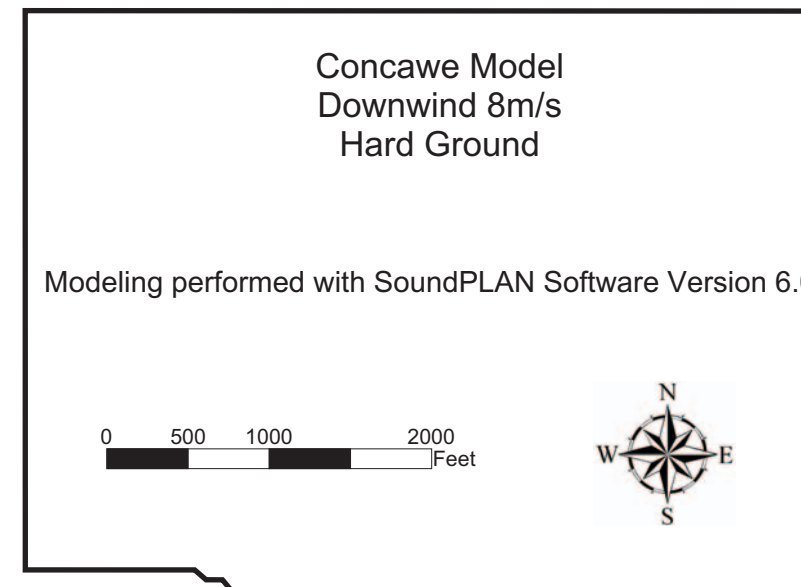
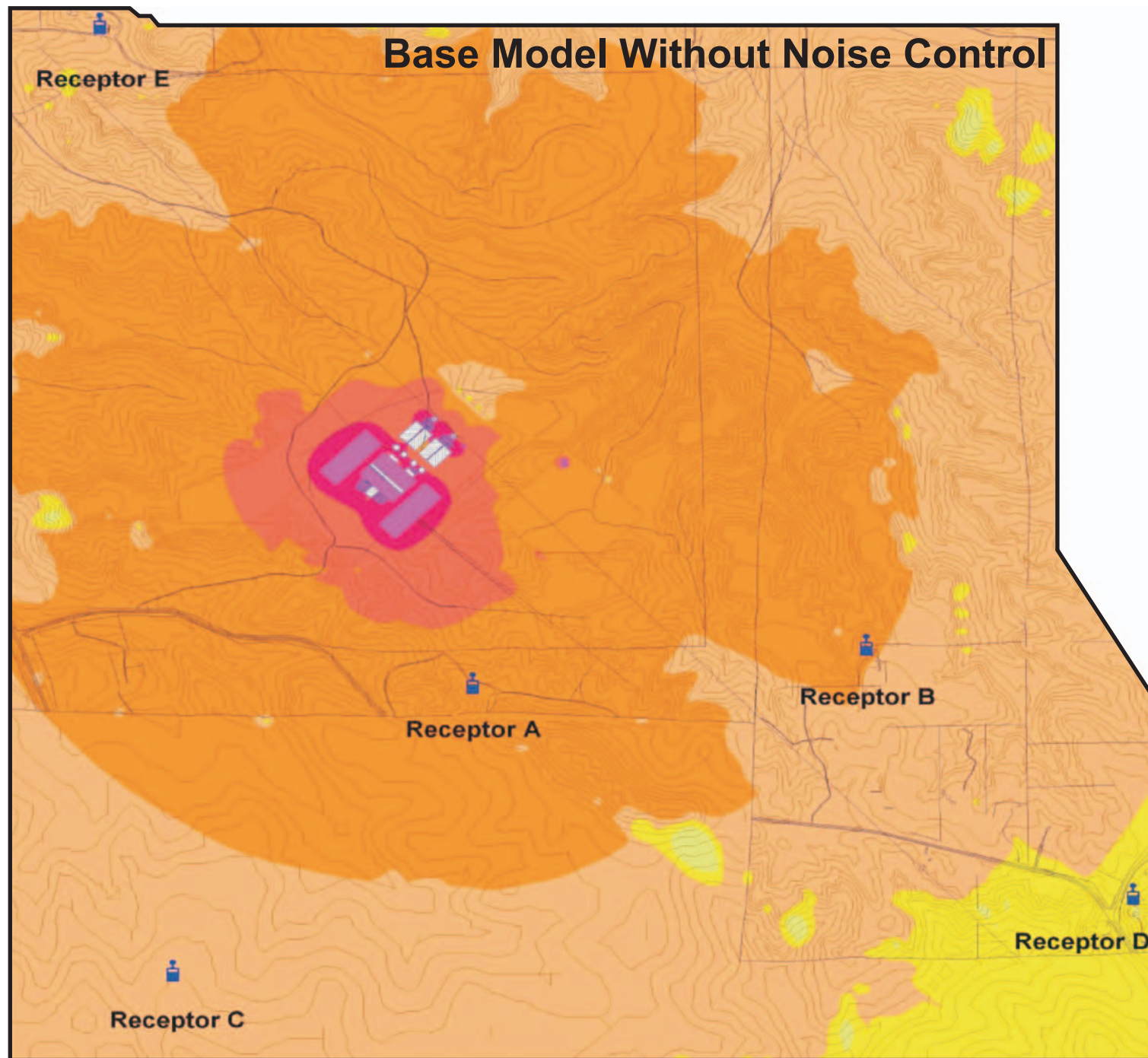
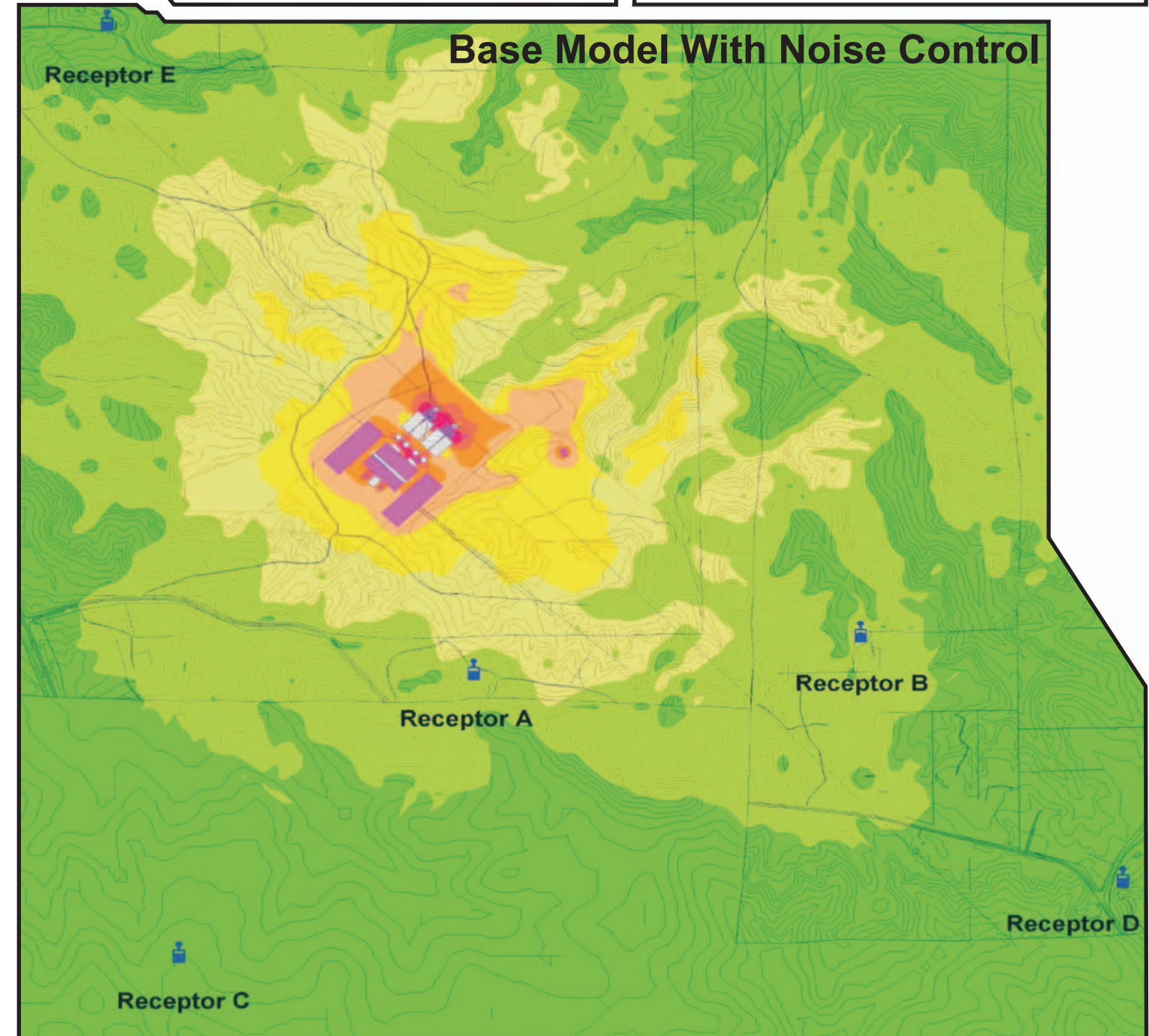
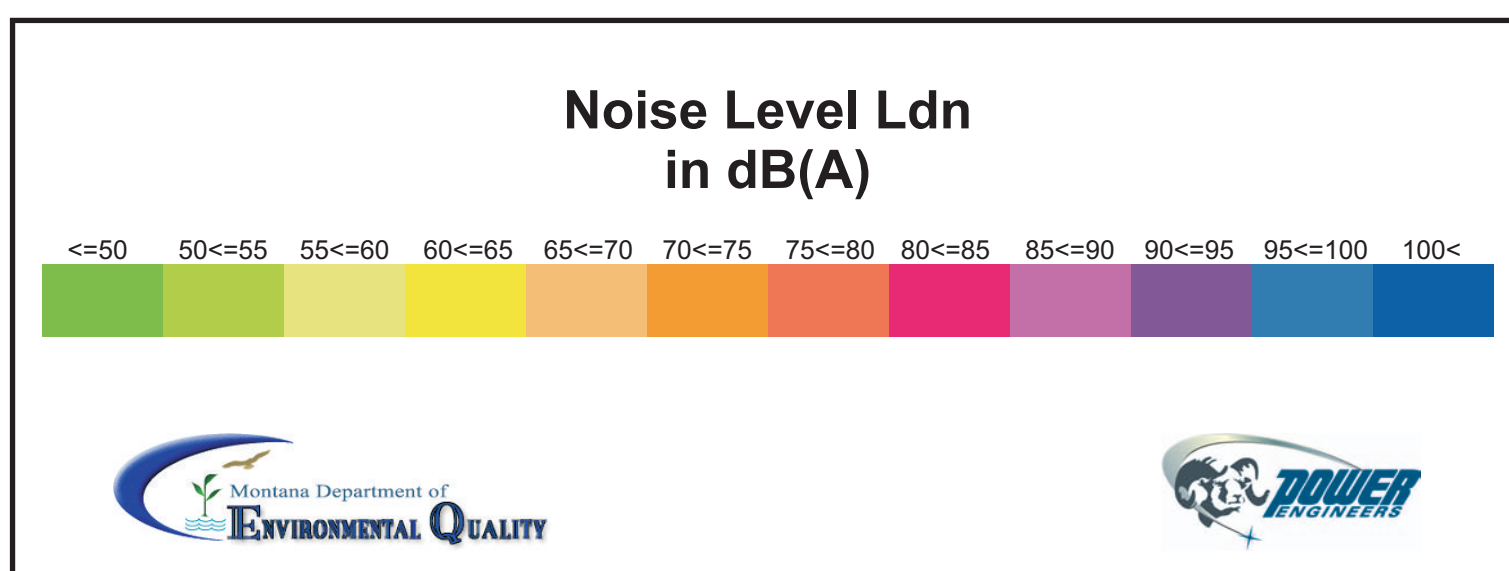

Figure 4-1

Noise Contours

Roundup Power Project DEIS



State Location

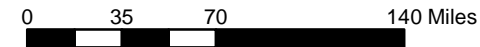
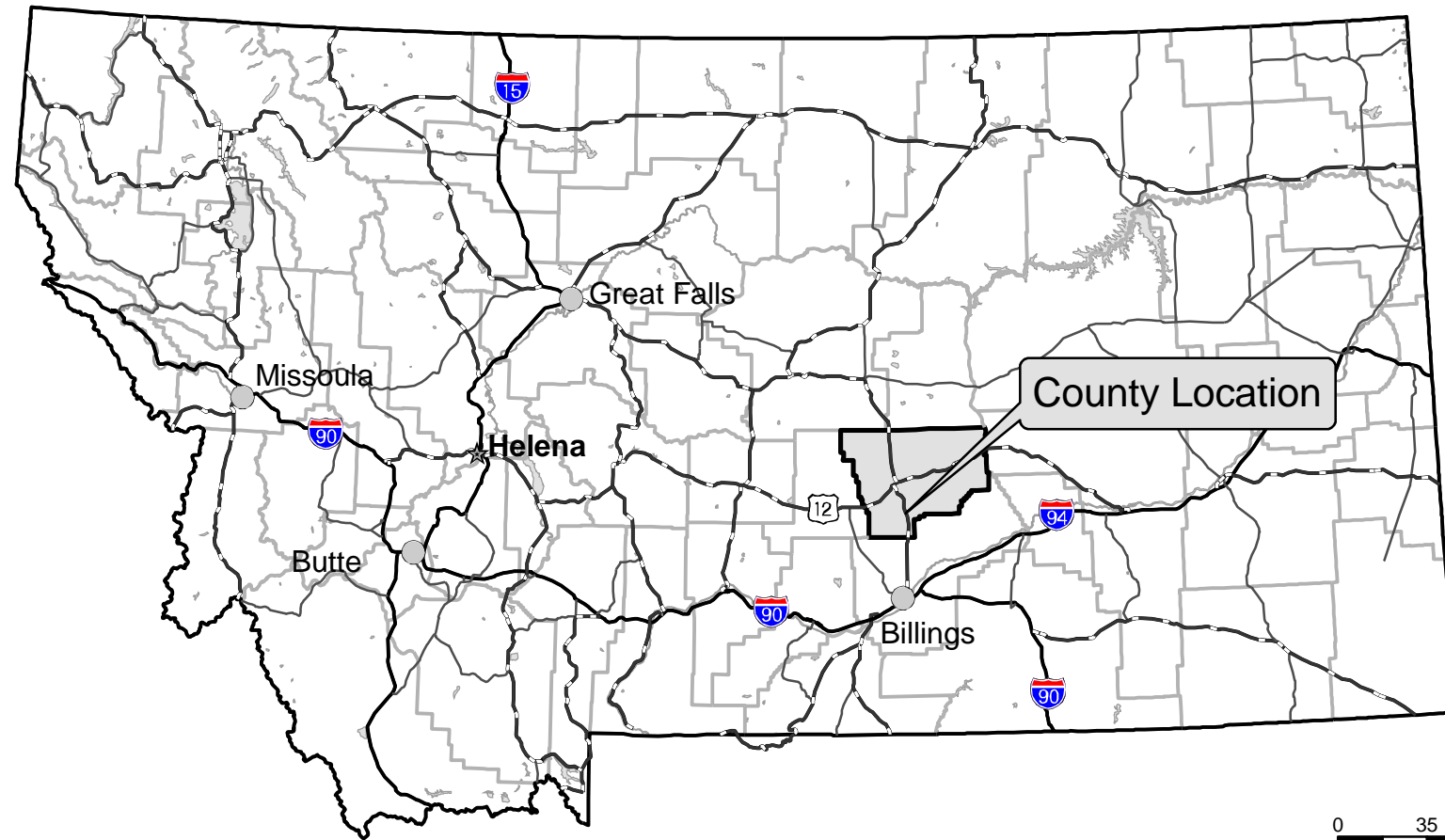













Figure ES-1

Vicinity Map

Roundup Power Project DEIS

Legend

-  Preliminary Transfer Location
-  Towns
-  Cities
-  State Capital
-  Conveyor Location
-  Proposed Transmission
-  Interstate Highway
-  U.S. Highway
-  State Highway
-  County Road
-  Proposed Railroad
-  County Line
-  Lake / Stream

County Location

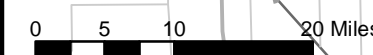
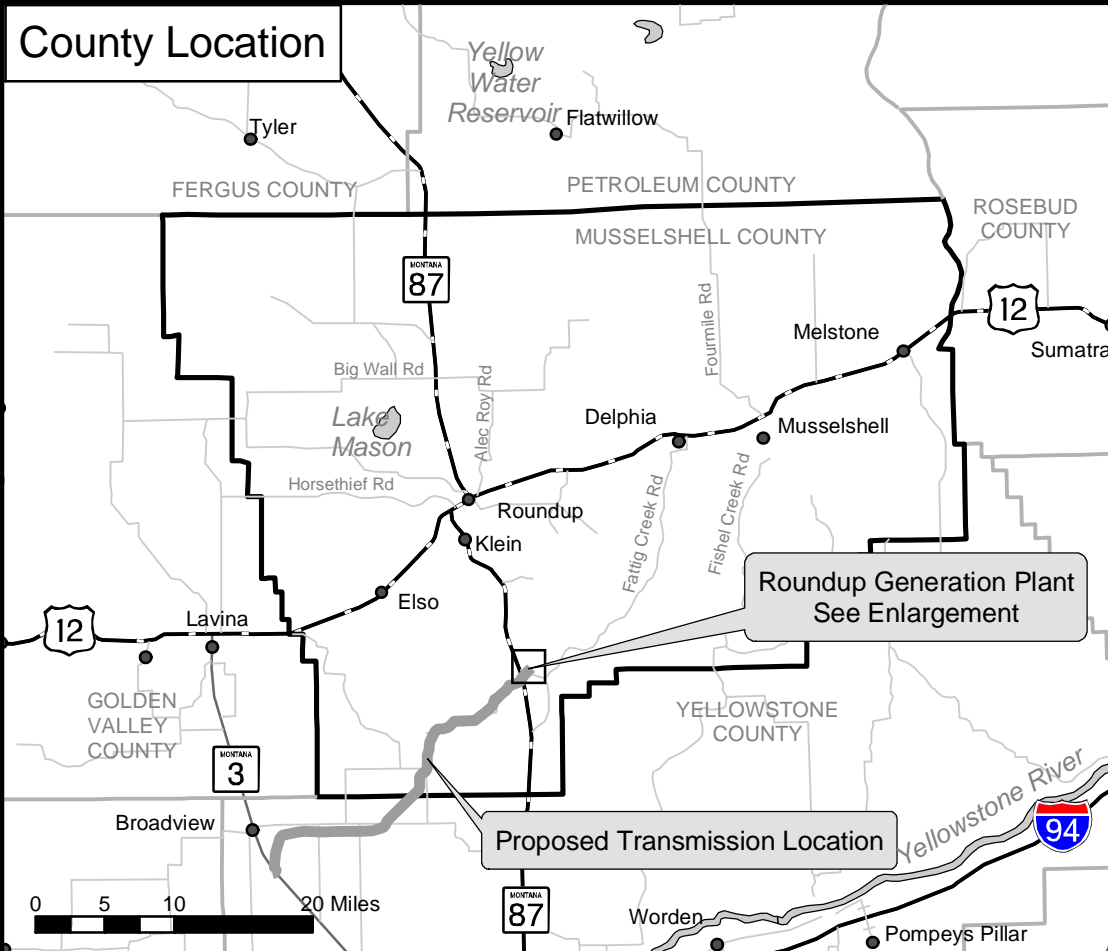

Roundup Power Project Location (Enlargement)

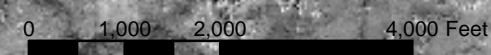
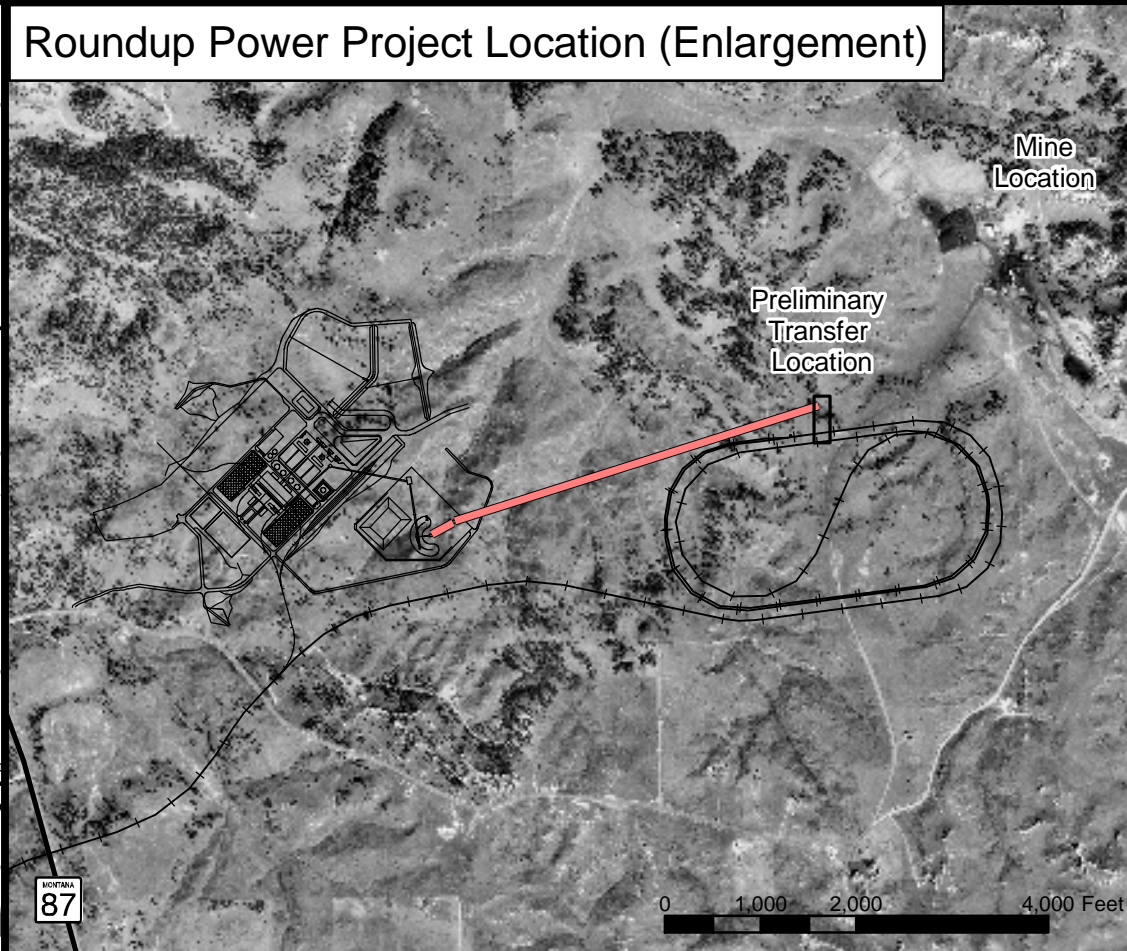

Table ES-1 Summary of Alternatives Considered But Eliminated

Screening Criteria	Energy Sources & Conveyance					Power Plant Processes								Waste Stream Treatment & Disposal						
	Alternative Fuel Sources					Alternative Water Sources			Cooling Systems	Alternative Combustion Systems			Generation Sites	Alternative Pollution Control and Solid Waste Treatment			Alternative Solid Waste Disposal Methods			
	Lower Sulfur Coal	Synthetic Fuels (e.g., shale oil, tar sands, etc.)	Coal Bed Methane	Gases	Fuel Cells	Yellowstone River	Musselshell River	Shallow Aquifers	Wet Cooling	Stoker	IGCC	Alternative Boiler Types	Gas Turbines / Combined Cycle		Ash & Wet FGD	Wet FGD	Separate Bottom Ash from Waste	Waste Rock Landfill	Off-Site Landfill for Life of Project	On-Site Landfill for Life of Project
Technical	Technically feasible, however coal-fired powerplants are designed to burn specific coal. Therefore, not technically feasible using the current design.	Technically feasible, but would not be feasible under current design. It is doubtful that the source could not solely support proposed load.	Technically feasible, but would not be feasible under current design. Source may not be available as fuel supply after 2008.	Technically feasible, but not feasible under the current design. There are many gas facilities planned throughout the country competing for limited supplies of gas.	Technically feasible, however not feasible under current design and for this size facility. Design is totally different and tied to gas or hydrogen.	Technically feasible - a pipeline could be constructed and water rights may be available.	Technically feasible, although there is not likely enough water consistently available from the Musselshell to make it a reasonable alternative water source.	Technically feasible, although not enough water is likely available from the shallow aquifer to make it a reasonable water source.	Technically feasible, although this would increase the amount of water needed and would result in additional water resource impacts.	Technically feasible, but not practical economically.	Technically feasible.	Cyclone and CFB boilers would be used to burn higher sulfur coal and use smaller boilers. Three CFB units would be needed. Solid waste would increase.	Technically feasible in one of many different configurations being used around the country.	Other sites are not feasible in order to utilize Bull Mountain coal.	Dewatering and treating.	Waste streams would have to be separated and treated.	Process would include keeping bottom ash separate from the fly ash and flu gas wastes. Disposal would be segregated.	Would need to modify Waste Rock Repository to accommodate and isolate Ash Lens.	Would require additional permits.	Would likely be difficult to accommodate waste disposal on-site for the life of the project due to limited space available.
Logistics	Cost would be much higher to transport coal from other mines.	There are no conveyances available for fuel supply.	There are no conveyances available for fuel supply.	There are no conveyances available for fuel supply.	There are no conveyances available for fuel supply.	Require pipelines, pump stations, and easements.	Require pipelines, pump stations, and easements.	Would require additional wells. Would draw down local wells in the area.	Would require completely different design and increase water use.	Would require completely new facility design. This system would burn more coal for same MW output.	Would require completely new facility design. This system would burn more coal for same MW output.	Would require completely new facility design. No gas lines are within the area that could supply the fuel requirements. Facility would burn more gas for same MW output.	The handling logistics of transporting coal to another site would make the plan uneconomical and therefore infeasible.	Would require adding slurry pipeline and pumps.	Would require adding slurry pipeline and pumps.	Would not affect air emissions. Would require separate handling and segregated disposal, thus increasing costs.	Would need to truck at least 20 loads of ash to waste rock area per day.	TSDf construction.	TSDf construction.	
Economics	Economics of the facility dependent upon an abundant supply of coal in the immediate vicinity as a mine-mouth project.	Economics of the facility rely upon an abundant supply in the immediate vicinity, of which there are none.	Economics of the facility rely upon an abundant supply in the immediate vicinity, of which there are none.	Economics of the facility rely upon an abundant supply in the immediate vicinity, of which there are none.	Economics of the facility are infeasible and cost prohibitive.	Would be much more expensive and would likely result in the costs being prohibitive.	Would be more expensive due to conveyance costs. Also, insufficient supplies of water would be available.	May or may not be more expensive, but supply is not likely to be sufficient.	Cost of additional water could increase costs.	More reasonable cost s but could not meet the expected outputs	No data, but costs per MW output would be expected to substantially increase.	No cost analyses were performed for these types of designs.	No cost analyses were performed for these types of designs.	Other generation sites would not be as cost effective as a mine-mouth concept, and would therefore be infeasible.	Most economical, but water supply is an issue for this project.	Most economical, but water supply is an issue for this project.	Additional handling and segregated disposal would likely be somewhat more expensive.	Assume costs are similar or somewhat higher because of additional logistics to coordinate waste rock and solid waste disposal.	Would be more expensive because of handling and transportation costs.	Would likely be more expensive for special design and handling to accommodate the solid waste on-site in limited space.
Regulatory Considerations	No expected changes in regulation except that new emission rates would have to be calculated and modeled.	No expected changes in regulation except that new emission rates would have to be calculated and modeled.	No expected changes in regulation except that new emission rates would have to be calculated and modeled.	No expected changes in regulation except that new emission rates would have to be calculated and modeled.	No regulations.	Would require water right acquisition.	Would require water right acquisition (e.g., purchase from irrigators).	Would require water right acquisition. Also, insufficient supplies would likely be available on a consistent basis.	Fugitive PM10 emissions from wet cooling towers would have to be calculated and included in modeling analysis.	No expected changes in regulation except that new emission rates would have to be calculated and modeled.	No expected changes in regulation except that new emission rates would have to be calculated and modeled.	No expected changes in regulation except that new emission rates would have to be calculated and modeled.	No expected changes in regulation except that new emission rates would have to be calculated and modeled.	Regulatory requirements could be somewhat different to accommodate transport of coal and water.	Air permit would need to be modified.	Air permit would need to be modified.	Solid waste permit would need to be modified to accommodate logistics and handling with waste rock.	Would have to modify permit to accommodate this type of disposal.	TSDf permit.	Would have to permit expanded facility to accommodate off-site disposal.
Potential Resource Impacts	Similar to Proposed Action.	Similar to Proposed Action.	Similar to Proposed Action.	Similar to Proposed Action.	Water Resource impacts. Air impacts would be minimized or eliminated.	Additional impacts to water resources, fisheries, and other resources from a pipeline.	Additional impacts to water resources, fisheries, and other resources from a pipeline.	Would likely result in impacts to wetlands and water resources, and could affect well production in the area.	Additional impacts to water quality and quantity.	Additional air, solids and water resource impacts would likely result.	Additional air, solids and water resource impacts would likely result.	Air emissions would likely be higher and solid wastes would be increased.	Similar to Proposed Action after air quality mitigation.	More impacts would result to air quality because of transportation costs for the fuel.	Solid waste treatment would be more difficult and would result in more impacts to water quality and quantity.	Solid waste treatment would be more difficult and would result in more impacts to water quality and quantity.	Likely would result in similar impacts as the Proposed Action.	Would increase size of Waste Rock Repository.	Could aggravate exposure to groundwater impacts.	Solid waste off-site would result in slightly higher environmental impacts, although waste stream not expected to have measurable effect on groundwater resources.
Reasonable/ Feasible	Not reasonable because of fuel transportation costs, increased cost of logistics, and would not meet the purpose and need for the Proposed Action.	Not economically feasible and would not meet the stated purpose and need for the Proposed Action.	Not economically feasible and would not meet the stated purpose and need for the Proposed Action.	Not economically feasible and would not meet the stated purpose and need for the Proposed Action.	Not economically feasible and would not meet the stated purpose and need for the Proposed Action.	Not reasonable because increased costs of pipeline and treatment would make the project infeasible.	Not reasonable because of increased costs of pipeline and treatment, and insufficient water supplies available.	Not reasonable because of insufficient water supplies available.	Common design, but increase in water usage would result in higher construction and operation costs and increased water resources impacts. Alternative is not reasonable.	Not reasonable because increased costs would make the project infeasible, thus not meeting the stated purpose and need.	Not reasonable because increased costs would make the project infeasible, thus not meeting the stated purpose and need.	Not reasonable because these boiler types are designed for different fuel not available at this location.	Not reasonable because turbines are designed for different fuel and since adequate supplies of gas are not available, this alternative is not feasible.	Would not reasonably meet the purpose and need for the Proposed Action because increased costs would make the project infeasible.	Not reasonable since this technology would require additional water and would result in higher impacts to water resources.	Not reasonable since this technology would require additional water and would result in higher impacts to water resources.	Additional handling and segregated disposal would likely be somewhat more expensive, and was eliminated from further consideration because of increased costs and handling with no benefit.	Not a reasonable alternative because additional logistics and costs with no benefit, and is considered and eliminated.	Is not reasonable because increased costs would result in no benefit.	Not reasonable because of space limitations.

Table ES-2 Alternatives Comparison Summary

		Table ES-2 Alternatives Comparison Summary					
		Proposed Action	Waste Disposal Alternatives		Transmission System Alternatives		No Action
			Proposed Action - Waste Disposal in Mine After 10 Years	Alternative - Expand Landfill After 10 Years (Preferred Alternative)	Proposed Action - 3 Circuits of 161kV Transmission	Alternative - Double Circuit 230kV Transmission Line	
		Roundup Power Project, as proposed	More information would be required for in-mine storage of waste ash with long-wall coal mining method.	Designed same as Proposed Action landfill; 3 times larger landfill area	161kV would require more circuits, shorter poles and shorter spans between poles than a higher voltage system to transport 750MW	230kV would require fewer circuits and larger conductors, taller poles but wider spans between poles, and different hardware than a lower voltage system to transport 750MW	Generation facility would not be constructed or operated. Transmission System and Waste Storage proposed action or alternatives would not be constructed and operated.
Resource Impacts	Ground Disturbance	208 acres of ground disturbance.	208 acres of ground disturbance	Additional ~70 acres would be disturbed to develop the waste disposal landfill and the road	Use existing roads; would need some new roads and upgrades to existing roads pending railroad spur construction; Ground disturbance on right-of-way (300 feet x 28 miles) for structures and access roads; most disturbance temporary.	Use existing roads; would need some new roads and upgrades to existing roads pending railroad spur construction; fewer circuits than lower voltage would require less labor and materials; Ground disturbance on right-of-way (300 feet x 28 miles) for structures and access roads; most disturbance temporary; Less ground disturbance because of fewer	Ground disturbance resulting from constructing and operating the generating facility and transmission lines would not occur.
	Water Resource	Impacts to ground water from in-mine storage of waste unknown; more studies would be required to assess impacts; zero discharge minimizes impacts on ground water resources from wastewater ponds and solid waste landfill	Impacts unknown and will require additional investigation, however could include elevated concentrations of TDS and metals and impacts to spring and well production.	Similar to Proposed Action.	Impacts would occur from access road construction, maintenance activities, and clearing of right-of-way, structure and work areas. Crosses several ephemeral drainages. No perennial streams crossed. Crosses the Hay Basin lakebed.	Similar to Proposed Action.	Water Resource impacts resulting from construction and operation of the generating facility and transmission lines would not occur.
	Earth Resources	Soil erosion impacts would be minimal due to control of runoff from the generation site.	Minor soil erosion would result from transport of waste from generating facility to mine site.	Minor soil erosion would result from transport of waste from generating facility to expanded landfill site.	Minor displacement of earth materials. Direct impacts to soils from access roads, and clearing of right-of-way, structure locations and work areas.	Similar to the Proposed Action; slightly less because of fewer expected structures.	Earth Resource impacts resulting from construction and operation of the generating facility and transmission lines would not occur.
	Biological and Wetland	Loss of ~207 acres of grass/shrubland for wildlife habitat, grazing and agriculture; no impacts to T&E species	No impacts to T&E species	Expanding the landfill would result in additional ~70 acres habitat loss. No impacts to T&E species	No impacts to T&E species	No impacts to T&E species	Biological impacts resulting from construction and operation of the generating facility and transmission lines would not occur.
	Cultural Resource	Archaeological site within the plant site would be impacted. 51 cultural resources within 3 miles of the 574-foot chimneys, of which 8 are considered visually sensitive.	Solid waste disposal haul road and conveyor belt could potentially affect a prehistoric lithic scatter.	Could have greater impacts than Proposed Action due to greater ground disturbance.	Three cultural resources identified within or near transmission route.	Similar to the Proposed Action, however the potential to disturb undiscovered resources may be slightly lower due to increased span length.	Cultural Resource impacts resulting from construction and operation of the generating facility and transmission lines would not occur.
	Visual	Visual impacts to residents and travelers from chimneys.	Low to non-identifiable impacts.	The expansion of the landfill would be more noticeable than the Proposed Action, but would result in only low visual resource impacts.	Visual impacts at road crossings and from scattered residences resulting from transmission lines.	Similar to the Proposed Action - Visual impacts at road crossings and from scattered residences resulting from transmission lines.	Visual impacts of constructing and operating the generating facility and transmission lines would not occur.
	Land Use	Conversion of currently available grazing and agricultural land to heavy industrial use. Recreation use at the plant site would be permanently lost.	Conversion of currently available grazing and agricultural land to heavy industrial use. Recreation use would be permanently lost.	Similar to the Proposed Action.	Crossing of non-irrigated cropland, livestock grazing land, and CRP land.	Similar to the Proposed Action.	Existing land uses would continue. No impacts to land uses from the generating facility and transmission lines would occur.
	Socioeconomic Benefits	Full economic benefits realized from implementation of the Proposed Action, including tax benefits to Musselshell County and the State of Montana, jobs created during construction and during the life of the project to operate and maintain the generating facility and to mine the coal.	Socioeconomic benefits would result from construction jobs, taxes for government agencies and social services, and long-term jobs from operation and maintenance of the facility.	Similar to the Proposed Waste Disposal - Socioeconomic benefits would result from construction jobs, taxes for government agencies and social services, and long-term jobs from operation and maintenance of the facility.	Socioeconomic benefits would result from construction jobs, taxes for government agencies and social services, and long-term jobs from operation and maintenance of the facility.	Similar to the Proposed Transmission Line System - Socioeconomic benefits would result from construction jobs, taxes for government agencies and social services, and long-term jobs from operation and maintenance of the facility.	Musselshell County and the State of Montana would not gain the tax benefits, jobs, and other socioeconomic benefits from operating the generation facility and transmission line, and would not gain the jobs and economic benefits from operating the Bull Mountain Mine to support the fuel needs of the generating facility.